

Zertified Management System

ISO 9001:2000
Reg.Nr. 12228

ALC 2000

USER'S GUIDE AND TECHNICAL REFERENCE

Document Nr. 31.10D35e

Rel. 4.2

Witschi Electronic Ltd

CH 3294 Büren a/Aare
Switzerland

Tel. +41 (0)32-352 05 00
Fax +41 (0)32-351 32 92
Internet www.witschi.com
E-Mail welcome@witschi.com



TABLE OF CONTENTS

	Page
1	BEFORE USING THE INSTRUMENT FOR THE FIRST TIME 5
2	INSTALLATION 6
2.1	Scope of the delivery 6
2.2	Installing the equipment..... 6
2.2.1	Mains Supply 6
2.2.2	Connecting the compressed air..... 7
2.2.3	Compressor..... 7
2.2.4	Printer connection..... 7
2.2.5	Print results and client label..... 7
3	OPERATION..... 8
3.1	Overview 8
3.2	ALC 2000 Starting Up and Setup 9
3.2.1	Language selection: 9
3.2.2	Display numerical (measured) results 10
3.2.3	Selecting the printer or the ASCII code 10
3.2.4	Counter..... 10
3.2.5	Identification Number..... 10
3.2.6	Predefined Measuring programs..... 11
3.2.7	Entering client label 11
3.2.8	Return to Main Menu 11
3.3	Switching on the ALC 2000 12
3.4	Programming the ALC 2000 12
3.4.1	Standard Program..... 12
3.4.2	Overview of the Measuring Programs..... 13
3.4.3	Testing under pressure and vacuum 13
3.4.4	Testing under pressure..... 13
3.4.5	Testing under vacuum..... 14
3.4.6	Customer specific test programs (P1- P10) 14
3.5	Programming example for user programs..... 15
3.5.1	User program selection 16
3.5.2	Lower pressure..... 16

3.5.3	Higher pressure	17
3.5.4	Stabilisation time	17
3.5.5	Measuring time	17
3.5.6	Tight limit.....	17
3.5.7	Case analysis.....	18
3.5.8	Save parameters.....	18
3.6	Measurements - General Comment	19
3.6.1	Prerequisite for reliable testing	19
3.7	Testing a watch.....	20
3.7.1	Maximum size of the Watch.....	20
3.7.2	Placement of the watch	20
3.7.3	Program selection	21
3.8	System Error Messages	24
3.8.1	Power failure	24
3.8.2	Chamber not closed	24
3.8.3	Chamber not tight.....	24
3.8.4	Sensor out of range.....	24
3.8.5	No air / no vacuum.....	25
3.8.6	The Chamber remains closed	25
4	INTERPRETATION OF RESULTS	26
4.1.1	Big leakage	26
4.1.2	Important leakage.....	26
4.1.3	Test 1(2) rejected -x.x%	26
4.1.4	Test 1(2) okay \pm x.x %	27
4.1.5	Test 1(2) okay / rejected ? \pm x.x.....	27
5	TECHNICAL DESCRIPTION	28
5.1	Measurement principle	28
5.2	Seal criterion	28
5.3	Interpretation of the results.....	29
5.3.1	Negative percentage	29
5.3.2	Positive percentage.....	29
5.4	Relationship to the ISO standard	30

6	MEASUREMENTS	31
	6.1 Measurement procedure	31
	6.1.1 Deformation initial value	31
	6.1.2 Pressure build-up	31
	6.1.3 Stabilization	31
	6.1.4 Minimum and maximum.....	31
	6.1.5 Pressure changes	31
	6.1.6 Measurement.....	32
	6.1.7 Pressure release	32
7	APPENDIX	33
	7.1 Typical deformation curves	33
	7.1.1 Ideal case.....	33
	7.1.2 Test 1(2) okay $\pm x.x\%$	33
	7.1.3 Test 1 and/or 2 rejected	34
	7.1.4 Important leakage	34
	7.1.5 Big leakage	35
	7.1.6 Deformation relief in plastic watches.....	35
	7.2 Table of Pressures	36
	Vacuum in dependence on the Altitude.....	37
8	TECHNICAL DATA	38
9	ACCESSORIES	40
10	MAINTENANCE.....	40
	10.1 Cleaning.....	40
	10.2 Calibration	40

Congratulations!

You have made an excellent choice.

By buying the **ALC 2000** you have chosen a test instrument which combines the highest of technical standards with an operating convenience specifically designed for practical applications.

If you operate it correctly, your new instrument will give you many years of service. We wish you much pleasure and success in its application.

1 BEFORE USING THE INSTRUMENT FOR THE FIRST TIME



Please carefully read all the information given in this User's Guide. It provides you with important instructions about the use, safety and maintenance of your instrument. Keep this manual in a safe place and if the occasion should arise, pass it on to subsequent users.

The instrument may only be used for the designed purpose in accordance with this Operating Instructions.

THE MANUFACTURER,

Witschi Electronic Ltd in CH - 3294 BÜREN a.A., Switzerland,

**ACCEPTS ABSOLUTELY NO RESPONSIBILITY FOR POSSIBLE DAMAGE TO THE
TEST INSTRUMENT, TO WATCHES OR PERSONS WHICH RESULTS FROM
IMPROPER OPERATION!**

2 INSTALLATION

2.1 SCOPE OF THE DELIVERY

The basic equipment consists of the following components:

- The **ALC 2000**
- Compressor air hose \varnothing 6 - 4 mm with nipple.
- 3 carriers for watches.
- Mains supply adapter, available for 230V~ or 120V~.
- Protective dust cover.
- Operating instructions.

2.2 INSTALLING THE EQUIPMENT

2.2.1 MAINS SUPPLY

The ALC 2000 is supplied from a mains adapter unit with an output of 9 V~ and a rating of 12 VA. The mains adapter is available for nominal mains voltages of 230 V~ (range 210 V~ to 240 V~) or 120 V~ (range 110 V~ to 130 V~).



Before connecting the instrument for the first time, check that the mains adapter unit voltage corresponds to your mains supply voltage.

Use only an original Witschi mains adapter unit.

Connect the mains adapter unit to the socket **9V~ 1.2A**.

In case you are not using the instrument for a long time (vacation), disconnect the mains adapter from the mains socket.

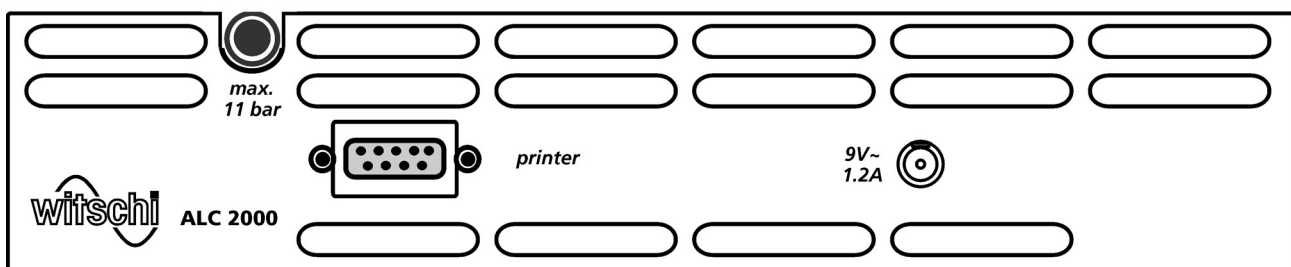

Rear panel ALC 2000

2.2.2 CONNECTING THE COMPRESSED AIR

Insert the open end of the compressed air hose supplied firmly into the quick coupling ***air pressure max. 11 bar.***

To extract the compressed air hose, press the (black) ring on the quick coupling towards the rear panel of the instrument while pulling the hose out of the aperture.

Connect the end of the hose fitted with a nipple to the compressor. The connecting nipple and the coupling are matched to one another when the compressor is supplied by Witschi Electronic Ltd.

2.2.3 COMPRESSOR

The ALC 2000 needs only compressed air to operate since the vacuum is generated within the unit. The unit can be connected to various compressed air sources but attention must, however, be paid to the following important points:



- **Maximum input pressure 11 bar.**
- **Use only oil-free, dry and dust-free air (use a filter).**
- **The input pressure must be 1 bar higher than the test pressure.**
- **The compressor must be equipped with a reservoir having a minimum volume of 4 liters for the vacuum test.**

Caution! Check whether the voltage stated on the compressor corresponds to the local mains voltage.

2.2.4 PRINTER CONNECTION

Before connecting the printer (available as an option), remove the protection from the connector ***printer.*** The appropriate interconnection cable is supplied with the printer.

Caution! Check whether the voltage stated on the printer corresponds to the local mains voltage.

2.2.5 PRINT RESULTS AND CLIENT LABEL

NOTE: Printing of results and 'client label' is automatic if the printer is connected.

At the end of each test the numerical value (measurement) is automatically printed.

The 'client label' is printed at the top of the paper strip on two lines in bold text with each output, for either the measured results or the selected test parameters.

The 'client label' is programmed in the setup mode (refer to section 3.2.6, page 12).

3 OPERATION

The following information will help you understand how to operate the **ALC 2000**. This chapter is organized into three sections: Overview, Programming the ALC 2000 and Testing a watch with the ALC 2000.

3.1 OVERVIEW

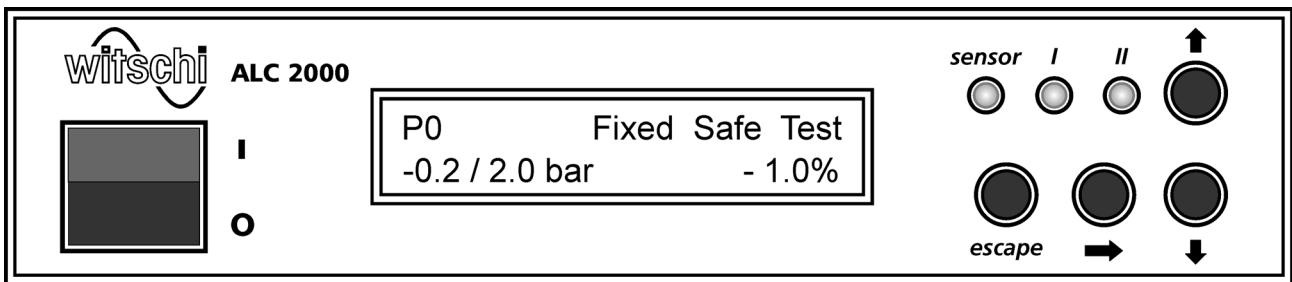

Figure 2
Front panel ALC 2000

Just four buttons on the front panel of the ALC 2000 is all that is necessary to operate the instrument. The buttons perform the following functions:

- **I/O** Switching ON / OFF the ALC 2000.
- **escape** Use this button to return to the main menu or to the **P0** standard measurement program from anywhere else in the program. **escape** is the help-button on the ALC 2000 with which you can *always* find your way back to the main menu from any of the sub-menus.
- **→** a) Parameter selection button.
b) If you keep the button pressed down while the measurement occurs, the exact value of the vacuum or the pressure will be displayed (i.e. 2.005 bar).
- **↑ ↓** Buttons to enter the required value (**↑** for +, **↓** for -).

The ALC 2000 communicates with you in clear-text. It is equipped with a back-lit LCD display for 2 rows of 20 characters. In addition, three LED's keep you informed of the measurement results at a glance as well as the sensor status. The functions of the three LED's are:

- **sensor** Lights up yellow to indicate when the watch has been correctly placed on the sensor.
- **I** Indicator Test 1 good (green), defective (red) or unsure (yellow).
- **II** Indicator Test 2 good (green), defective (red) or unsure (yellow).

3.2 ALC 2000 STARING UP AND SETUP

When switching the unit on for the first time, keep the → button pressed in and switch the unit on by means of the I/O switch. This will enable you to enter the first part of setup mode **Change language**.

Change language * E N G L I S H *

3.2.1 LANGUAGE SELECTION:

The following languages are available:

Vael Sprog * D A N S K *
Sprache wechseln * D E U T S C H *
Change language * E N G L I S H *
Cambiar lengua * E S P A N O L *
Changer langue * F R A N C A I S *
Cambiare lingua * I T A L I A N O *
Velg Sprak * N O R S K *
Valitse Kieli * S U O M I *
Välj Sprak * S V E N S K A *

Select the required language by means of the ↑ ↓ buttons. All the texts will now be displayed and be printed-out in the selected language. Return to the previous menu by pressing the **escape** button or:

after pushing the → key you go to the next setup mode.

3.2.2 DISPLAY NUMERICAL (MEASURED) RESULTS

You can, additionally, switch the display and print-out of the tightness value on or off. Proceed as follows:

Display numerical results?	Yes
----------------------------	-----

Select either **Yes** or **No** with the **↑** or **↓** buttons and then press the **escape** button, or:
after pushing the → key you go to the next setup mode.

3.2.3 SELECTING THE PRINTER OR THE ASCII CODE

Printer?	Citizen
----------	---------

Select with the **↑** or **↓** buttons the printer type: Citizen, Martel or the standard ASCII code for the data transfer and then press the **escape** button, or:
after pushing the → key you go to the next setup mode.

3.2.4 COUNTER

Tests:	0000000093
--------	------------

Number of test cycles which have been carried out, since the equipment has been put into operation. The counter can not be set to zero. Press the **escape** button, or:
after pushing the → key you go to the next setup mode.

3.2.5 IDENTIFICATION NUMBER

IDN:	XXXXX
------	-------

The ALC 2000 is provided with a serial number and therefore it can be identified at any time. The number can neither be changed nor be erased.
after pushing the → key you go to the next setup mode.

3.2.6 PREDEFINED MEASURING PROGRAMS

Program Eeprom	
Std Values	Yes (No)

The internal memory contains 6 predefined measuring programs (P1 up to P6). These programs have been arranged for the most common watch types and are an ideal supplement for the specialist shop and for the watch service.

Select with the **↑** or **↓** button Yes or No.

Remark: Even if you have selected *Yes* you may edit the program parameters at any time you would like to make adjustments.

*after pushing the **→** key you go to the next setup mode.*

3.2.7 ENTERING CLIENT LABEL

Witschi Electronic CH-3294 Bueren a.A.

There will be a cursor under the first character. You may select one of the printable characters by pushing the **↑** or **↓** keys. After pushing the **→** key the cursor moves to the next character which you may select like the previous one, etc. After entering your label (max. 2 x 20 characters) you may push the **escape** key to save it and to return to the LANGUAGE SELECTION mode. This text will not be displayed on the LCD screen when you later turn on the unit, but will print out on the printer when you need to provide printed results.

3.2.8 RETURN TO MAIN MENU

This is the end of the setup mode. Now push **escape** to save changed parameters and return to the Main Menu.

3.3 SWITCHING ON THE ALC 2000

Switch the unit on with the **I/O** switch. The following display is presented for about 3 seconds once power has been applied:

Witschi Electronic
ALC 2000 Serie Vx.x

Vx.x = Software release

The unit carries out the following functions during this time:

The actuating mechanism makes an opening movement and opens the chamber in case it was closed before the unit was powered-up. Finally the same program as that which was in use when the unit was last switched off is shown again, for example:

P1	Auto/Stnd
-0.2 / 3.0 bar	-1.0%

3.4 PROGRAMMING THE ALC 2000

The ALC 2000 can be programmed for specific test situations. Watches are made with water resistant values of anywhere from 10 to 100+ meter pressures. You may want to program a test for each of the most common types of water resistant watches. With the 10 programs in the ALC 2000 you can change the parameters as needed. The 10 existing programs (P1-P10) contain factory default values.

3.4.1 STANDARD PROGRAM

The ALC 2000 contains 1 fixed standard program. This is labeled in the LCD display as P0. It cannot be changed. The display looks like the following:

P0 Fixed Safe Test
-0.2/2.0 bar -1.0%

The display parameters are explained later, but have the basic meaning as follows:

- Auto** = the measuring time is automatically selected based on the amount of deformation measured.
- 1.0%** = the tight limit.
- Stnd** = the type of watch case; Standard or Hard.
- 0.2** = the vacuum pressure in bar.
- 2.0** = the air pressure in bar.
- bar** = the atmospheric pressure of 1 bar = 1.02 kg/cm².
- Fixed Safe Test** = the program is fixed, cannot be changed.

The P0 program will display when you turn on the ALC 2000, if it was the last program you used, or if you at any time push the **escape** button. **P0** is a standard program which can be used for all types of watches, without risk to be damaged.

3.4.2 OVERVIEW OF THE MEASURING PROGRAMS

Each program, P1 to P10 can be individually programmed for customer specific applications. The following diagram shows you the overview of the programs contained in the ALC 2000:

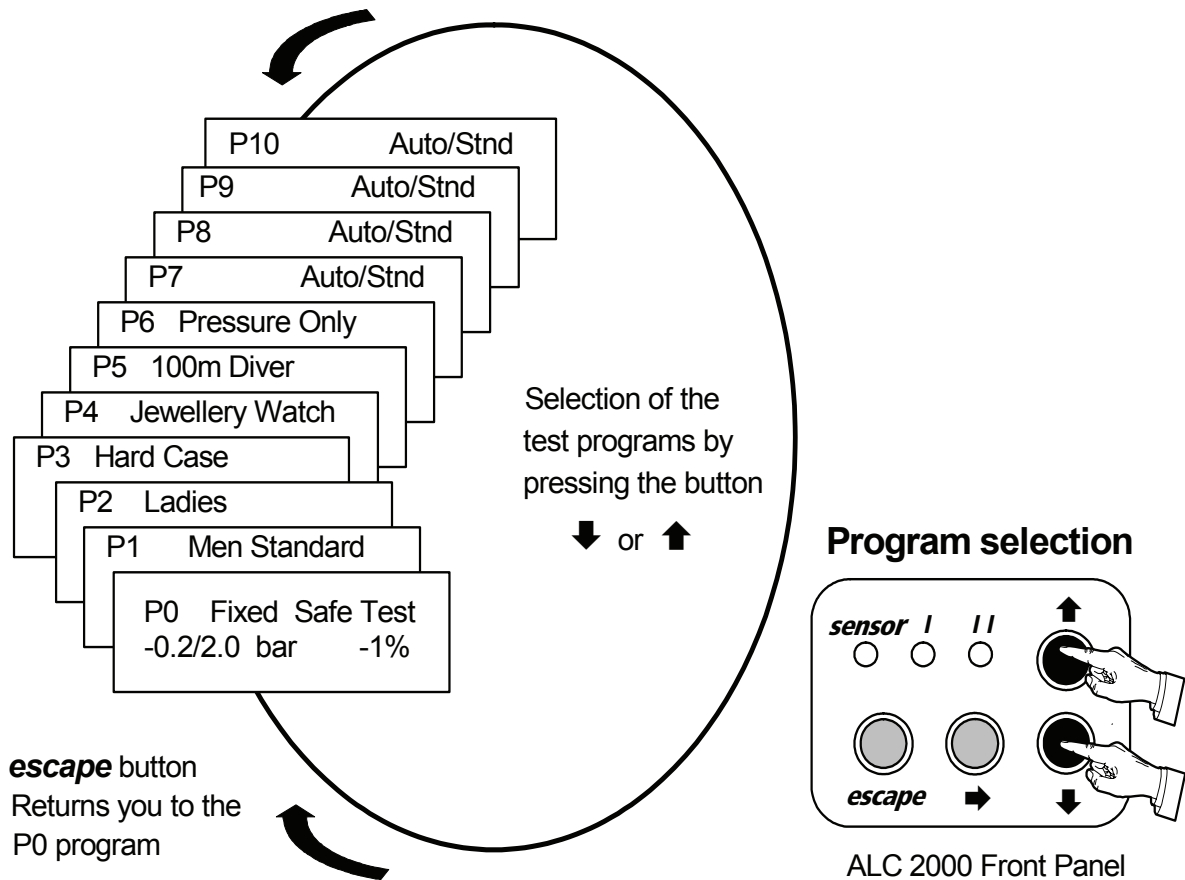

Figure 3 ALC 2000 Program Selection

3.4.3 TESTING UNDER PRESSURE AND VACUUM

A leak is most likely to be detected through a combined test using both vacuum and pressure in which the watch is subjected once to expansion and once to compression.

3.4.4 TESTING UNDER PRESSURE

Do not test a watch at too high a pressure. This is particularly true for watches with plastic cases which could be so greatly compressed that the mechanism is damaged. Normal, water resistant wristwatches may be tested with a maximum pressure of 2 bar. Watches that are designated with a maximum pressure or a maximum depth of water may be tested at a pressure up to the specified limit (10 m depth of water = 1 bar pressure).

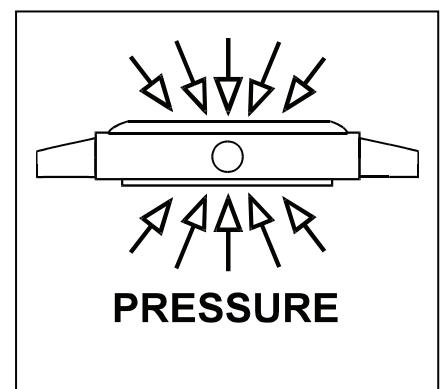

3.4.5 TESTING UNDER VACUUM

The **greatest care** is called for when testing decorative dress-watches or very thin watches under vacuum! The rear cover and, depending on the construction, even the glass could be lifted by the vacuum. We recommend that such watches are first tested under a **low** pressure or vacuum. If your ALC 2000 is equipped with a compressor having no reservoir then the measurement programs under vacuum are inoperative.

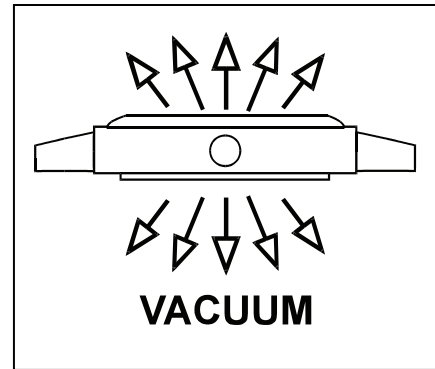

A leak is most likely to be detected through a combined test using both vacuum and pressure in which the watch is subjected once to expansion and once to compression.

3.4.6 CUSTOMER SPECIFIC TEST PROGRAMS (P1- P10)

The possibility to input and store product-specific test programs is one of main advantages of the ALC 2000. The 10 measurement programs (**P1** to **P10**) can be set up to match your requirements by changing the parameters of a program. (The parameters shown in the following examples are arbitrary, and may not be the factory installed values appearing on your unit.)

The following combinations for the test sequence and the parameters can be entered for each of the P1-P10 programs:

- Test with vacuum
- Test with 2 pressures
- Values for vacuum and pressure
- Storing of the programs
- Test with 1 pressure
- Test with vacuum and 1 pressure
- Measuring time and tight limit
- Print-out of parameters

When the P1 or other Px program is displayed you may change parameters by pressing the → key. Upon pressing this key the following series of displays will be shown.

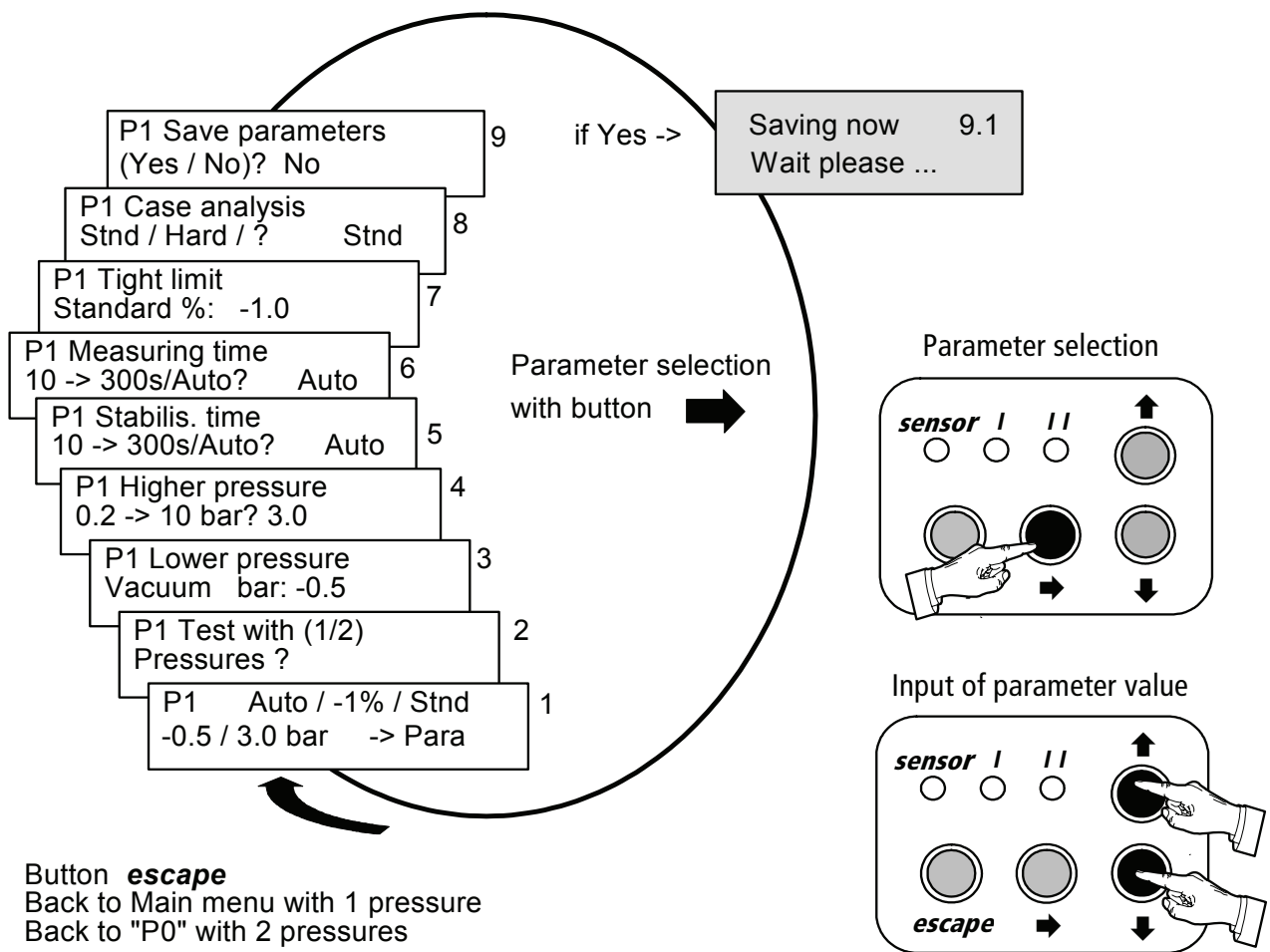

NOTE: Depending on the selection of one or two pressures the display sequence will be different

Figure 4
P1-P10 Programming

3.5 PROGRAMMING EXAMPLE FOR USER PROGRAMS

A large number of watches has one of the following or a similar marking on the back of the case:

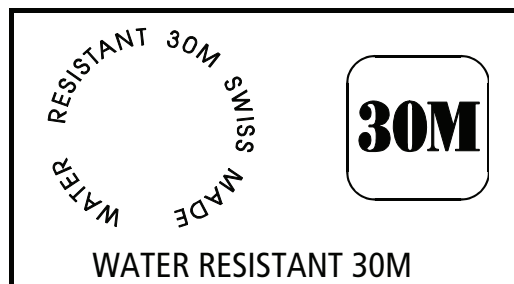

How is a program for this category of watch created? The following example shows you how you can input and store a suitable program.

Example: P1

First test with vacuum **-0.5 bar**, then test with pressure of **3 bar**.

The prerequisites for the procedure specified are:

- The test unit is switched on and initialized.
- The ALC 2000 is in the input mode for program selection.

Note: You can always return to the first standard program **P0** by briefly pressing the *escape* button.

Use the **→** key when P1 is displayed to select which parameters to change. Then use the **↑** or **↓** keys to change the values. When you push escape the new values are automatically saved. If you turn off the unit while the P1 is displayed it will return after turning on the unit later. The following will be a step by step clarification:

3.5.1 USER PROGRAM SELECTION

Use the **↑** **↓** buttons to select **P1**. The program will be displayed with any previously stored parameters.

P1	Auto/Std
-0.3 /2.0 bar	- 1%

The shaded area contains factory default values, or values you programmed previously.

Press the **→** button to go into the input mode. The following display appears:

P1 Test with (1/2)	
Pressures?	2

Use the **↑** **↓** buttons to select two pressures.

*Proceed to the next menu item by pressing the **→** button.*

3.5.2 LOWER PRESSURE

Display for the **Lower pressure** input:

P1 Lower Pressure	
-0.8 → 1.0 bar?	-0.x

Selectable values for the vacuum are: **-0.2 / -0.3/ -0.4 / -0.5 / -0.6 / -0.7** and **-0.8 bar** (a pressure of 0.2 to 9.0 bar can also be chosen). The input is made by means of the **↑** **↓** buttons. Input the value **-0.5 bar**.

*Proceed to the next menu item by pressing the **→** button.*

3.5.3 HIGHER PRESSURE

Display for the **Higher pressure** input:

P1 Higher Pressure	
0.2 → 10 bar?	x.x

Values available for the pressure selection from **0.2** to **1.0 bar** in steps of **0.1 bar**, from **1.0** to **2.0 bar** in steps of **0.2 bar**, from **2.0** to **5.0 bar** in steps of **0.5 bar** and from **5.0** to **10.0 bar** in steps of **1.0 bar**. The input is made by means of the **↑ ↓** buttons. Input the value **3.0 bar**.

*Proceed to the next menu item by pressing the **→** button.*

3.5.4 STABILISATION TIME

Display for the **Stabilisation time** input:

P1 Stabilis. time	
10 → 300s/ Auto?	Auto

Here you can input the required measuring period. Use the **↑ ↓** buttons to select a value between **10 s** and **300 s** or **AUTO**.

*Proceed to the next menu item by pressing the **→** button.*

3.5.5 MEASURING TIME

Display for the **Measuring time** input:

P1 Measuring time	
10 → 300s/ Auto?	Auto

Here you can input the required measuring period. Use the **↑ ↓** buttons to select a value between **10 s** and **300 s** or **AUTO**. If you choose **AUTO** the ALC 2000 calculates the measuring time automatically according to the deformation measured.

*Proceed to the next menu item by pressing the **→** button.*

3.5.6 TIGHT LIMIT

Display for the **Tight limit** input:

P1 Tight limit	
Value % ?	-1.0

Sets the limiting value for the classification of the watch as being either **water resistant** or **not water resistant**. Possible input values are **-0.1, -0.2, -0.3, -0.4, -0.5, -1.0, -1.5, -2.0, -2.5** and **-3.0%**. The standard value of **-1.0%** should be selected for normal applications. This corresponds to the criteria of the ISO 2281 Standard (50 µg/min) for watches having an average housing volume.

Extremely small or large watches, customer-specific setting

The deformation limit is the tolerance limit on which the ALC 2000 evaluates the measured amount of deformation. If the deformation relief exhibited by a watch exceeds the specified value then the watch is classified as being **poor**.

Should you wish to adjust the evaluation tolerance to suit your requirements, then:

- a lower %-value gives the result **poor** with an even smaller amount of relief.
- a higher %-value tolerates a larger amount of deformation relief.

We recommend the following values for watches with a particularly small or large volume cases:

- -1.5 % for very small watches
- -0.5 % for very large watches

(see the section on Relationship to the ISO-Standard on page 29).

Proceed to the next menu item by pressing the → button.

3.5.7 CASE ANALYSIS

Display for the **Case analysis** input:

P1 Case analysis (Stnd/Hard)?	Stnd
----------------------------------	------

Use the ↑ ↓ buttons to choose **Stnd** or **Hard**. We propose the following:

- **Hard** if the deformation of the watch is less than 1.5 µm but minimum 0.35 µm.
- **Stnd** for tests with low pressures or vacuum. For measurements with vacuum or pressures which are lower than 1 bar the deformation limit is 0.35 µm.

Proceed to the next menu item by pressing the → button.

3.5.8 SAVE PARAMETERS

Display for the **Save parameters** input:

P1 Save parameters (Yes/No)?	No
---------------------------------	----

Use the ↑ ↓ buttons to choose **Yes** or **No** to specify whether to save the parameters or not. If the parameters **are not saved** then they are only valid until the unit is switched off. If the unit is switched off and then on again then the parameters that were saved **before the changes were made** will again be taken as being valid.

Once the parameters have been **saved** they remain stored even **after** the unit has been switched off. When the unit is switched on again the now newly entered and saved parameters are taken as being valid.

The following display is presented for a period of about 1 second after you have selected **Save parameters Yes** and then pressed the → button:

Saving now Wait please . . .

The parameters are written to the EEPROM. After this the unit goes to the main menu.

3.6 MEASUREMENTS - GENERAL COMMENT

When taking measurements with the ALC 2000 it must be borne in mind that the deformation being measured is extremely small and even minimal influences can affect the accuracy of the measurement.

A robust watch (diving watch) will deform by about 3 µm (3 thousandths of a millimeter) under a pressure of 0.5 bar. This watch would be rejected as being poor if the deformation relaxed by more than 0.06 µm (0.06 thousandths of a millimeter) after 1 minute.

The more robust the watch is and the lower the test pressure that is selected, the smaller the resultant deformation and the trickier the measurement. The deformation must be at least 1.5 µm after the pressure has been applied for a satisfactory measurement to be taken (at least 0.35 µm for the **Hard Case Test** program). If the deformation is less than this figure, the test is terminated and the message **large leakage** or **not compressible watch** is displayed. Usually such a watch has a large leak which results in an instantaneous pressure equalization.

The measured deformation can also be too small to be evaluated in the case of a robust watch being subjected to a test pressure that is too low. The test must be conducted at a higher pressure in such cases.

3.6.1 PREREQUISITE FOR RELIABLE TESTING

The following conditions can falsify the measurement:

- **Watch poorly inserted.**

A reliable measurement is not possible, for example, if the watch is laid on one side of the wrist strap since the strap will deform during the measurement in an unpredictable manner. The sensing table should be set up high for watches with wrist straps so that the strap interferes with the measurement as little as possible. The case of the watch to be tested must rest on all three contact points on the sensing table.

- **Adhesive label or protective foil under the watch casing**

A adhesive label on the underside of the watch casing leads to an increased plastic deformation during the measurement because the layer of adhesive is slowly indented by the contact points when the pressure is applied. This effect can give the impression of a leak when a measurement is made with a vacuum or a small leak can be obscured in measurements using pressure. Labels and protective foils must therefore be removed before a measurement is taken. A thinly applied coating of protective lacquer on the underside of the watch normally has no significant effect on a measurement.

- **The temperature of the watch is not the same as the ambient temperature.**

A watch will deform in an unpredictable manner as it warms or cools which can completely falsify the results of a measurement. A watch that has been worn on the arm must hence be allowed to cool to the ambient temperature before being tested.

- **Shock while the measurement runs.**

A watch can move slightly on the sensor table if it is subjected to shock which would falsify the result of the measurement.

- **Previous test at a higher pressure.**

A watch must be allowed to recover for a few minutes following a test performed at high pressure to permit the deformation to relax and, in the case of a leaky watch, for the pressures to equalize. The result is unreliable if a test is conducted with a low pressure or a vacuum shortly after a test at high pressure. (In the case of measurement programs using two different pressures the first one must always be lower than the second pressure that is applied).

3.7 TESTING A WATCH

3.7.1 MAXIMUM SIZE OF THE WATCH

Please pay attention to the maximum dimensions of the watch casing.

- Circular watch case: maximum \varnothing 52mm, maximum height 20mm.
- Other watch case types: maximum dimension 56 x 44mm, maximum height 20mm.

3.7.2 PLACEMENT OF THE WATCH

First, move the sensor upwards using the knob **A**. The support table **B** can be adjusted in height by pressing the knobs on the side. It should be set as high as possible for watches with an arm-band.

Lay the watch on the three coated steel pillars of the support table **B**. Ensure that the watch is well seated and that the arm-band is lying in the plastic retainer. In case of difficulty it can be advantageous to place the watch face-down (**C**) or to use an intermediate ring.

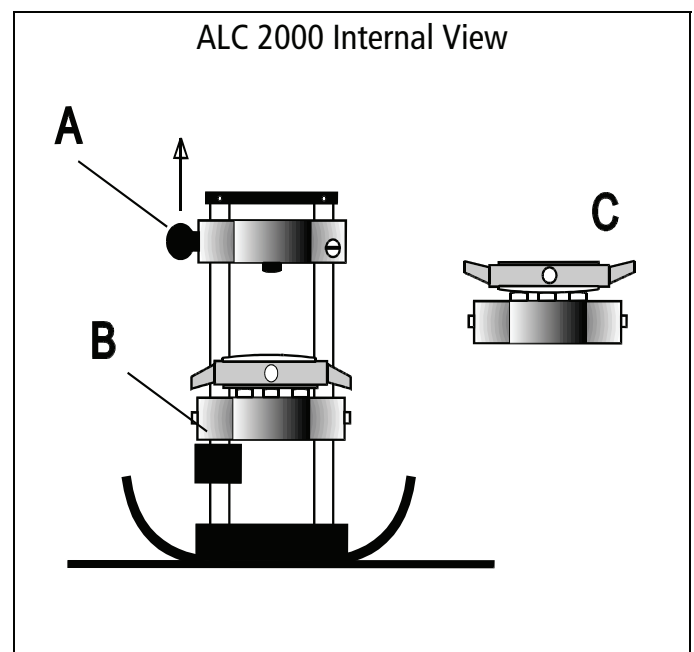
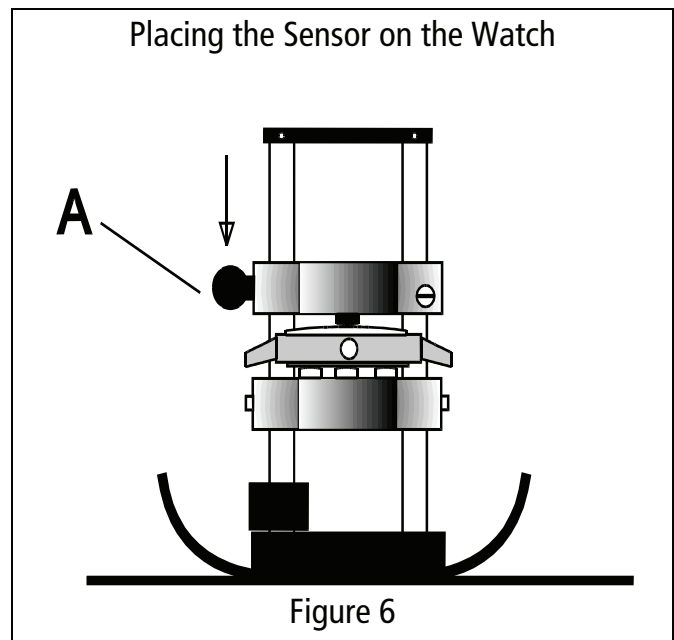

Figure 5
Placing the watch

Finally, release the sensor by slightly lifting the knob **A** and then lowering it until it rests on the watch. The LED *sensor* shows when the watch is correctly placed.

3.7.3 PROGRAM SELECTION

Select the program with which the watch is to be tested from the main menu by using the **↑** **↓** buttons.



Example: Program **P1** - First test with a vacuum value of **-0.5 bar**, next test with a **3 bar** pressure.

Lower the measuring chamber once the watch has been positioned and the yellow LED *sensor* has been illuminated.

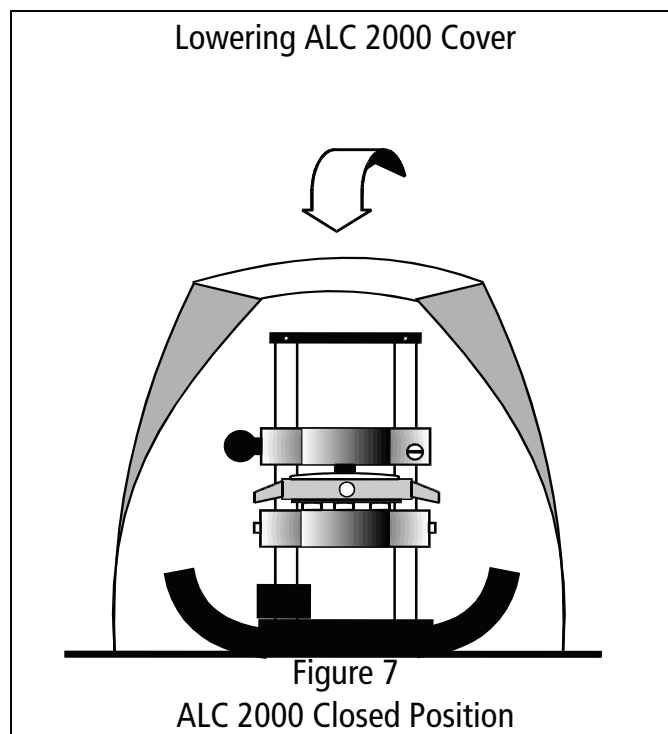

It will be automatically locked and the following display appears for a few seconds:

P1	-0.5 bar
Locking the chamber	

and then during the build up of the vacuum:

P1	-0.5 bar
Air	- x.x bar

The actual value appears in place of -x.x until the programmed vacuum is attained.

The first measurement is begun once this vacuum has been achieved. Meanwhile the display shows the count-down of the stabilization period and the maximum deformation incurred by the watch, thus:

P1	-0.5 bar	60s
Stabilizing		- 025.6 μ

The watch undergoes some further deformation after the vacuum has been attained. An evaluation during the stabilization time (min. 30 s) determines whether the deformation is remaining stable or is increasing / reducing a little.

The measurement begins once the deformation is stable or the stabilization time (max. 60 s) has elapsed. The unit determines the measurement time automatically in our example (from 10 to max. 300 s). The count-down of the measurement time and the measured change in the deformation are displayed, thus:

P1 T	-0.5 bar	20s
Measuring		- 0.02 μ

T = Thermal, i.e. a wrong measurement may occur due to a thermal influence (just before testing, the watch was worn for a longer time). The test will be repeated (without stabilization time) if the measurement is **rejected**. The **T** will not be displayed anymore. This test mode is only used for the first test under vacuum.

The deformation has increased by -0.02 μ at the end of the measurement period in our example. The green LED " **I** " lights up and the display shows that Test 1 has been completed successfully.

P1	-0.5 bar	00s
Test1 okay		+1.8%

If a printer is connected, the result of the first test will be printed out after the second test has been finished. The pressure for the second measurement phase is built up and the display changes to:

P1	3.0 bar
Air	- x.x bar

The actual value appears in place of -x.x until the specified value is reached.

The second measurement begins once this vacuum has been achieved. Meanwhile the display shows the count-down of the stabilization period and the maximum deformation incurred by the watch, thus:

P1	3.0 bar	60s
Stabilizing		+133.4 μ

The watch undergoes some further deformation after the pressure has been attained. An evaluation during the stabilization time (min. 30 s) determines whether the deformation is remaining stable or is increasing / reducing a little.

The measurement begins once the deformation is stable or the stabilization time (max. 60 s for automatic mode) has elapsed. The unit determines the measurement time automatically in our example (from 10 to max. 300 s). The count-down of the measurement time and the measured change in the deformation are displayed.

Remark: the exact value of the vacuum or the pressure will be displayed (i.e. 2.005 bar), if you keep the button → pressed down while the measurement occurs.

P1	3.0 bar	10s
Measuring		+ 0.03 μ

The deformation has increased by +0.03 μ at the end of the measurement period in our example. The green LED II lights up and the display shows that Test 2 has been completed successfully.

Test1	okay	+1.8%
Test2	okay	+3.1%

The results of the first and second measurement are printed out if a printer is connected. The result shown on the display and the LED's remain unchanged until a new measurement is started.

Remark: The display and the print-out of the tightness values (in our example) +1.8% and +3.1%) can be switched on or off (see chapter 3.2.3, page 10).

If you press the **escape** button the LED's remain unchanged but the display changes to show the program that has just been used. In our example:

P1	Auto/Std
-0.5 /3.0 bar	- 1%

Any error messages that might occur are listed below together with their meaning and the appropriate remedy.

3.8 SYSTEM ERROR MESSAGES

3.8.1 POWER FAILURE

A momentary power interruption has occurred. Switch the unit off

Power failure Switch Off

and then switch it back on again.

3.8.2 CHAMBER NOT CLOSED

The chamber has re-opened. No automatic locking has taken place.

Measurement stopped Chamber not closed

Close the chamber again by pressing down on it a little more firmly so that the locking latches can engage properly.

3.8.3 CHAMBER NOT TIGHT

A large pressure or vacuum loss has been detected.

Measurement stopped Chamber not tight
--

The chamber opens automatically.

Check the sealing ring and the contact surface of the chamber for cleanliness and wipe clean as necessary. It is advisable to smear a little silicon grease on the sealing ring from time-to-time.

3.8.4 SENSOR OUT OF RANGE

The chamber re-opens immediately after having been closed. There are two basic possible reasons:

Measurement stopped Sensor out of range
--

- no watch is present
- the sensor has not made contact with the watch.
- the sensor may have been pressed too hard against the watch

Check that the sensor is sitting well on the watch and that the LED *sensor* has been illuminated.

3.8.5 No AIR / NO VACUUM

The chamber opens again after having been closed.

Measurement stopped No air / no vacuum

Too little or no pressure is present. The vacuum or the pressure for the measurement cannot be produced. Check to ensure that the compressed air connection is sound, that the compressor is switched on and that the valve on the reservoir is open. The message **No vacuum** can also appear if you attempt to use a compressor without a reservoir.

3.8.6 THE CHAMBER REMAINS CLOSED

Because of an electrical or a mechanical defect, the chamber remains closed.

Motor ! Switch Off

By means of an emergency unlock mechanism the chamber can be opened manually. Proceed as follows:



1. **First** the equipment **must be switched off** by means of the mains switch **I / O**. The remaining air pressure in the chamber will be released.
2. An opening is located to the left side of the wooden frame. Remove the cover. Then you can open the chamber while, by means of a screwdriver, you turn the screw head of the emergency unlock mechanism located in the opening **counter-clockwise**.
3. Check the cleanness of the seal. If necessary, remove the seal from the basic plate. Clean it carefully as well as the surface on the bottom side of the chamber and the seal groove on the basic plate by means of a smooth and dry cloth.

Please consult our After-Sales Service at our Head Office or our Agency, if you cannot eliminate the defect by taking these measures.

Caution:

Equipments from previous series have not been equipped with the emergency unlock mechanism.

In this case do not try to break open the chamber by means of a screwdriver or a similar tool!

Please consult our After-Sales Service at our Head Office or our Agency.

4 INTERPRETATION OF RESULTS

4.1.1 BIG LEAKAGE

If the test pressure is higher than 1.0 bar, then following message appears:

Big leakage or not compressible watch
--

If the deformation is less than 1.5µm after the pressure has been applied then the watch either has a large leak that rapidly equalizes the pressure, or it is so hard that it is insufficiently deformed by the applied pressure.

Should this happen, try testing the watch by selecting **Hard** in the menu **Case analysis**.

If the test pressure is lower than 1.0 bar, then following message appears:

Lower pressure Deformation too small

4.1.2 IMPORTANT LEAKAGE

Detection of an important leakage

The watch deforms as the pressure is applied but, because it has a sizable leak, there is a considerable amount of deformation relief. The deformation relief exceeds 15% per second.

4.1.3 TEST 1(2) REJECTED -X.X%

Test 1(2) rejected	-X.X%
--------------------	-------

The watch deforms normally during the pressure increase and stabilization period. A certain amount of deformation relief is measured during the measurement time. The amount of this relief is, however, **greater** than the programmed deformation limit.

4.1.4 TEST 1(2) OKAY \pm X.X %

Test 1(2) okay	\pm X.X%
----------------	------------

The watch deforms normally during the pressure increase and stabilization period. A small amount of deformation relief is measured during the measurement time. The amount of this relief is less than the programmed deformation limit.

The value for the deformation limit refers to a measurement time of 60 seconds.

4.1.5 TEST 1(2) OKAY / REJECTED ? \pm X.X

Following display appears if you test with a fix selected measuring time which is too short for an accurate measurement:

Test 1(2) okay/rejected ?	\pm X.X %
---------------------------	-------------

and the yellow LED I or II lights up.

5 TECHNICAL DESCRIPTION

5.1 MEASUREMENT PRINCIPLE

The ALC 2000 checks the water-tight seal on watches by means of the deformation principle. The watch to be tested is clamped into a highly sensitive path measurement system that continuously measures and monitors the thickness of the watch. Having closed the measurement chamber, the watch is subjected to a specified, programmable test pressure. The watch is slightly compressed by this pressure.

The amount of deformation remains constant while a constant pressure is applied provided the watch is watertight. In the case of an imperfect seal, the air that leaks into the watch causes an internal pressure equalization which allows the watch case to tend back towards its original thickness.

A microprocessor measurement system evaluates the change in the amount of deformation according to specified criteria.

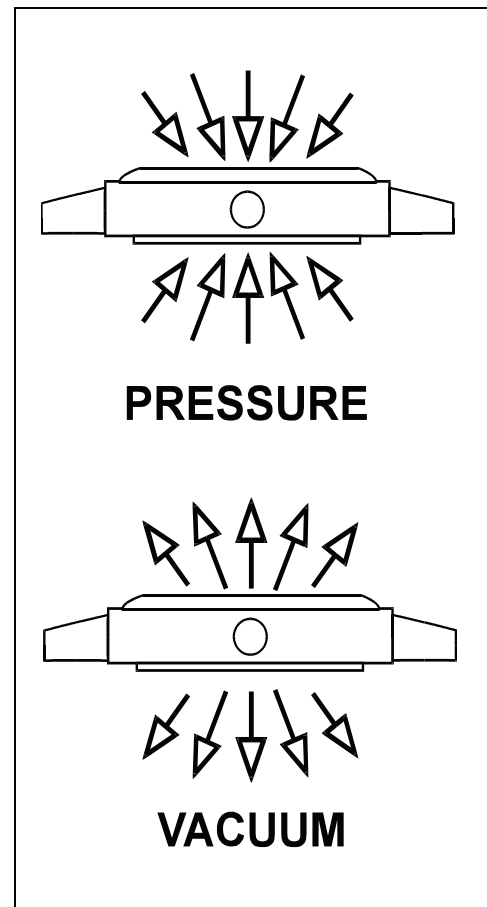

5.2 SEAL CRITERION

The ALC 2000 measures the deformation incurred by the watch as the test pressure is applied and then decompressed during the measurement period. The rate at which the deformation relaxes provides a measure of the leak rate into the watch.

The ALC 2000 calculates the relaxation as a percentage of the initial deformation as measured over a period of 1 minute. The percentage of deformation relief that results from a particular size of leak depends on the test pressure applied. The percentage value is always referred back to a pressure of 2 bar so that comparative results can be obtained irrespective of the test pressure applied. The true result is suitably converted if the test pressure is not 2 bar.

Deformation limit - Definition

The criterion for the decision "watertight"/"leaky" is called the deformation limit and is set at 1% per minute for the standard programs, referred back to a pressure of 2 bars. A value lying between -0.5% and -3% can be selected for customer-specific programs.

The more severely the deformation limit is set, the longer the measurement time has to be in order to achieve the necessary accuracy in the measurement of the deformation relief. A value of 0 cannot be selected since such a criterion could lead to erroneous results because of the distribution of the measurements obtained.

5.3 INTERPRETATION OF THE RESULTS

A positive or negative percentage value appears on the display at the end of a test in addition to the good/poor indication.

This value represents the percentage change in the deformation during the measurement. The value is referred to a measurement time of 60 seconds and a pressure of 2 bar; the result having been correspondingly converted for other measurement conditions.

Through this reference to specific measurement conditions (corresponding to the ISO 2281 Standard) it is possible to compare the results of different measurements directly with one another.

5.3.1 NEGATIVE PERCENTAGE

A negative percentage value means that the deformation has relaxed. This generally means that the watch is not watertight. The greater the percentage value the larger the leak that the watch has. Small negative values can also result from instabilities in the measurement. The watch is classed as being leaky when the negative value is greater than the programmed deformation limit.

5.3.2 POSITIVE PERCENTAGE

A positive percentage value means that the deformation has increased slightly still further after the stabilization time has elapsed. Most watches exhibit a plastic characteristic to some extent or another, that is, the deformation continues to increase slightly after the pressure has been applied and only settles to a stable state after a period of time. The stabilization time should not be made arbitrarily long otherwise unreasonable test times will result. The deformation can hence be expected to increase slightly during the measurement phase for a well-sealed watch with a plastic characteristic. The reliability of the measurement is not affected by small positive values for the deformation. A large increase in the deformation during the measurement phase can disguise a small leak and make the measurement unreliable. In such cases it is recommended to start the test again since the plastic deformation is usually less during a second measurement under the same conditions.

A watch with a certain size of leak should, theoretically, always give the same result during various tests at the same or various pressures. In practice, however, the size of the opening changes with the pressure so that the leak can appear to be bigger or smaller or even disappear altogether (this is why it is recommended to conduct a water resistant test at both a lower and a higher pressure). Even a repetition of a measurement at the same pressure can produce differing results since the size of the opening can change with mechanical deformations.

5.4 RELATIONSHIP TO THE ISO STANDARD

The ISO 2281 Standard specifies that a watch qualifies as being watertight if less than 50 µg of air flows into the casing per minute under a test pressure of 2 bar.

The weight of the air that leaks into a watch cannot be measured directly in a water resistant test using the deformation principle. By making certain assumptions it is, however, possible to determine a relationship between the air that leaks in and the deformation relief.

In the case of a medium sized wristwatch (2250 mm³ free internal volume) and a test pressure of 2 bar, a leak rate of 50 µg air per minute corresponds to a deformation relief of 1% per minute. This value corresponds to the deformation limit set in the standard programs.

The ISO 2281 Standard does not take the volume of a watch into account, i.e. the leak rate of 50 µg per minute applies to all watches irrespective of their size. The ALC 2000 automatically takes the volume of the watch into account since a lower absolute leak rate can be permitted for a small watch than that for a larger one. If the volume is not to be taken into account during a measurement (test strictly in accordance with the ISO Standard) then the deformation limit must be programmed in relation to the free volume in the watch concerned. Approximate values are -0.5% for large watches, -1% for medium sized watches (default value) and -1.5% for the smaller watches.

The Standard is based on a test pressure of 2 bar; no leak rates being specified for other pressures. The amount of air that flows through a certain size of leak depends on the test pressure. The ALC 2000 takes this dependency into account and converts the results obtained so that they are referred back to a pressure of 2 bar. A watch with a fixed size of leak should theoretically give the same result at any test pressure. In practice, however, the magnitude of a leak is often largely dependent on the pressure applied so that the actual results obtained can differ somewhat.

Remark:

Bearing the above explanation in mind, a water resistant measurement using the ALC 2000 can be made in keeping with the ISO Standard and the results will be largely in agreement. Since the measurement principle used in the ALC 2000 does not conform with the ISO 2281 Standard, no 100% agreement can however be guaranteed.

6 MEASUREMENTS

6.1 MEASUREMENT PROCEDURE

6.1.1 DEFORMATION INITIAL VALUE

An initial value for the deformation is measured once the test chamber has been closed. This value is then taken as the zero point for the measurement of the deformation itself.

6.1.2 PRESSURE BUILD-UP

Once the deformation zero point has been determined, an inlet valve opens and air flows into the measurement chamber. The pressure is shown continuously on a LCD display. The inlet valve closes as soon as a pressure of about 5% over the nominal level has been achieved. This over-pressure is necessary since the pressure always sinks slightly due to thermal effects.

6.1.3 STABILIZATION

Most watches exhibit a plastic characteristic to some extent or another, that is, the deformation continues to increase slightly after the pressure has been applied and only settles to a stable state after a period of time. The increase in the deformation can disguise a small amount of leakage so no precise measurement is possible during this time. The deformation is shown continuously on the display during the stabilization period.

6.1.4 MINIMUM AND MAXIMUM

The stabilization period is automatically terminated once a maximum deformation has been determined or when the increase drops to below 0.03 μm per second. The minimum stabilization period is 10 s for measurements under pressure and 30 s for measurements under vacuum. The maximum corresponds to the chosen measurement time or 60 s in the case of automatic measurement time selection. The elapse of the stabilization period is shown on the display.

6.1.5 PRESSURE CHANGES

The pressure is also not stable during the initial phase. The air is warmed during the compression stage and then cools down again to the ambient temperature.

This temperature change causes a corresponding pressure change which also affects the deformation. Effects on the deformation caused by pressure changes are automatically compensated by the ALC 2000 so that small pressure fluctuations have no effect on the measurements taken.

The deformation relief is also monitored during the stabilization period albeit according to a less severe criterion compared with that used during the measurement itself.

If a sizable leak has already been detected during the stabilization phase, the measurement is terminated and the message **Large leak detected** is displayed.

6.1.6 MEASUREMENT

At the beginning of a measurement, the latest deformation value taken is stored as the new zero-point. The deviation from this value is then shown on the display during the measurement.

The ALC 2000 can automatically calculate the minimum time necessary in order to obtain a reliable measurement. The measurement time is determined by the limited resolution and stability of the deformation measurement. A smaller deformation or a more severe criterion concerning the water resistant necessitates a correspondingly longer measurement time. The elapse of the measurement period is shown by a down-counter on the display.

A fixed measurement time can also be specified in customer-programs. If the programmed, fixed measurement time is too short the result obtained will be unreliable. Such a situation is indicated by a question mark being placed beside the result and the good/poor indicator lighting up yellow.

In the case of a leaky watch the measurement is broken off as soon as a relief of the deformation is detected that corresponds the seal criterion.

At the end of the measurement, the change in the deformation is shown on the display as a percentage relative to a measurement time of 60 seconds and a pressure of 2 bar.

6.1.7 PRESSURE RELEASE

The pressure is released at the conclusion or following a termination of a measurement and the chamber opens automatically.

If a large leak has been detected during a test the pressure is reduced slowly in steps so that any over-pressure in the watch casing can be equalized and hence prevent damage to the watch.

7 APPENDIX

7.1 TYPICAL DEFORMATION CURVES

7.1.1 IDEAL CASE

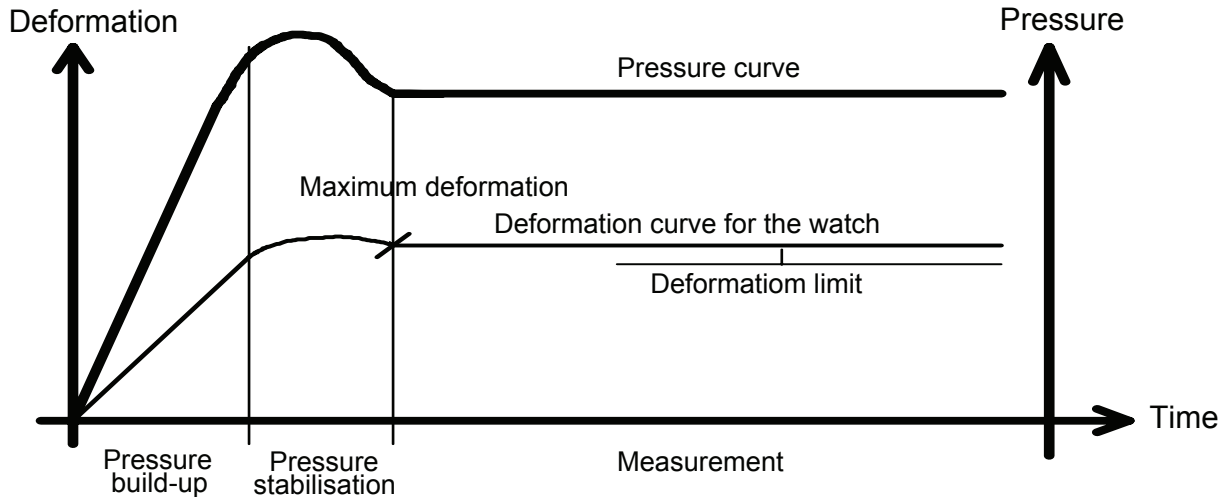

After the pressure has stabilized within the chamber, the watch deformation remains unchanged for the duration of the measurement period ⇒ **The watch is okay**

7.1.2 TEST 1(2) OKAY ± X.X%

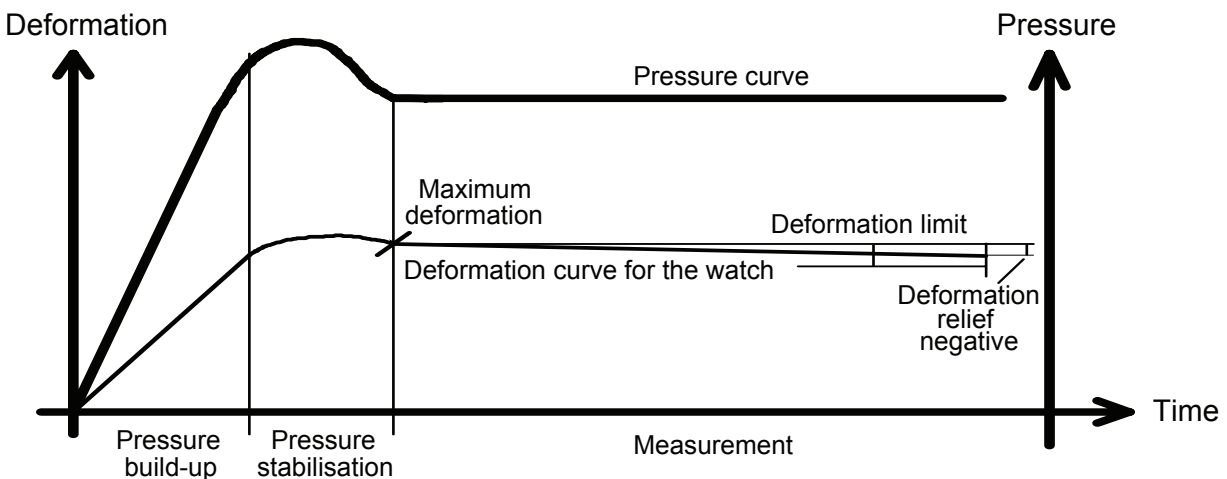

The watch deforms normally during the pressure increase and stabilization period. A small amount of deformation relief is measured during the measurement time. The amount of this relief is **less** than the programmed deformation limit.

The value for the deformation limit refers to a measurement time of 60 seconds and is calculated as follows:

$$\frac{\Delta * 60}{Max_deformation * Measurement_time} < K * Deformation\ limit \rightarrow \text{Test 1(2) okay}$$

7.1.3 TEST 1 AND/OR 2 REJECTED

The watch deforms normally during the pressure increase and stabilization period. A certain amount of deformation relief is measured during the measurement time. The amount of this relief is greater than the programmed deformation limit.

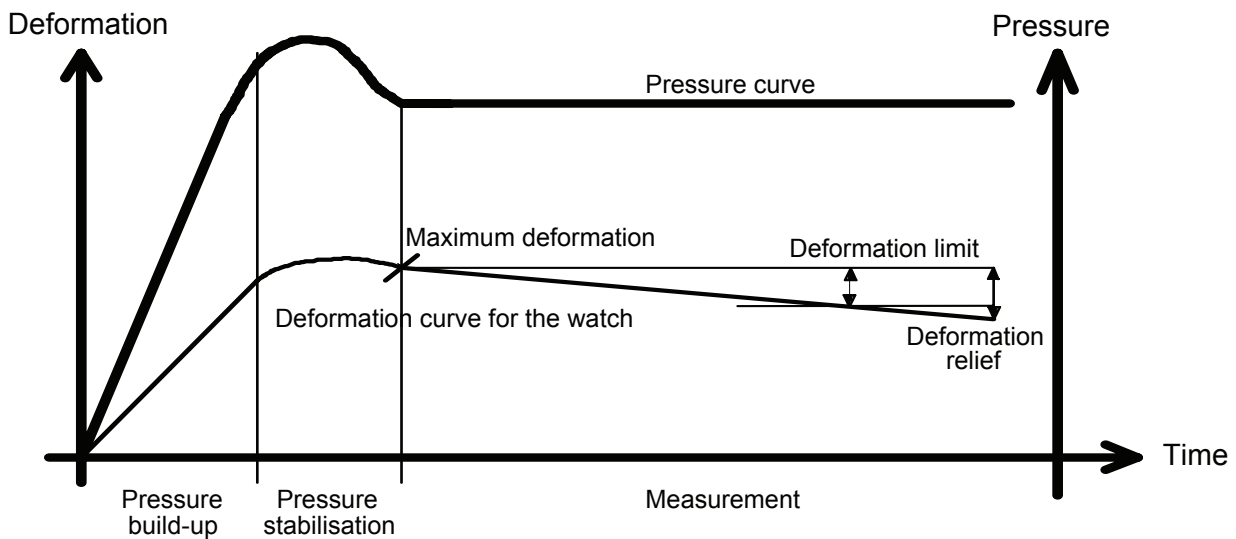

7.1.4 IMPORTANT LEAKAGE

The watch deforms as the pressure is applied but, because it has a sizable leak, there is a considerable amount of deformation relief. The deformation relief exceeds 15% per second.

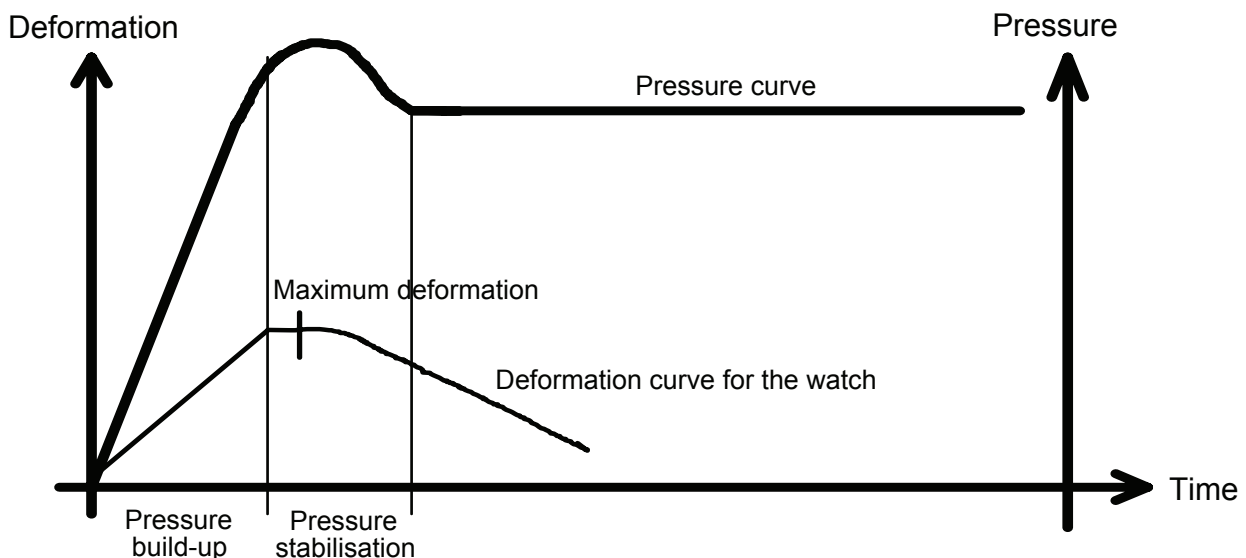

Important leakage is indicated if:
$$\frac{\Delta(1_sec) * 60}{Max_deformation} > 0.15$$

7.1.5 BIG LEAKAGE

The watch does not deform when a pressure or a vacuum is applied. There are two possibilities for this kind of result:

- The watch has a large leak so that air flows quickly into or out of the casing and the pressure inside and outside is the same. No deformation can hence be measured after the stabilization time.
- The watch is very solidly made and so does not deform (test pressure too low).

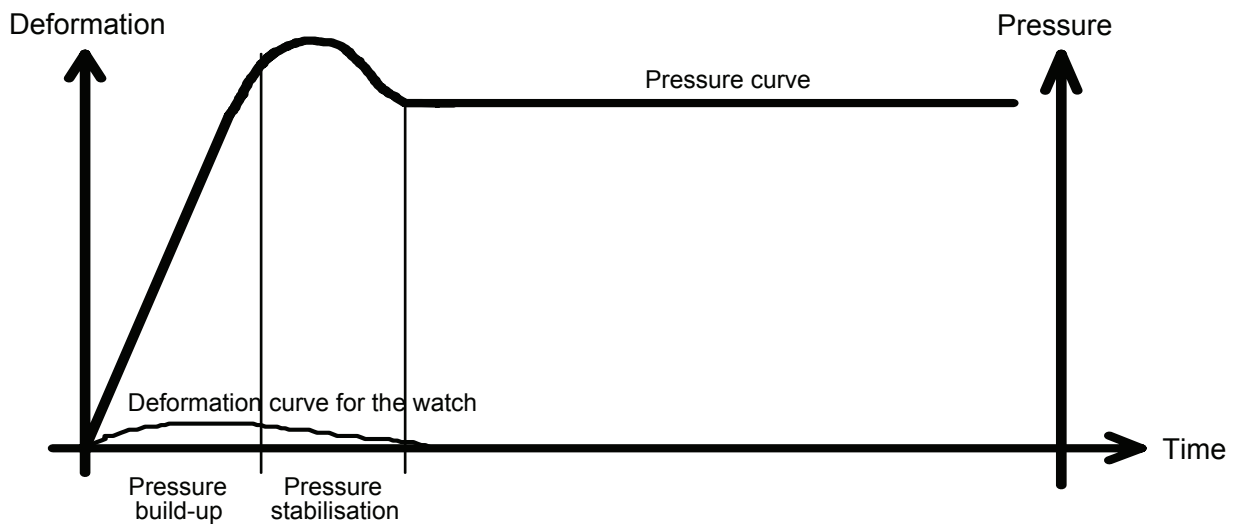

7.1.6 DEFORMATION RELIEF IN PLASTIC WATCHES

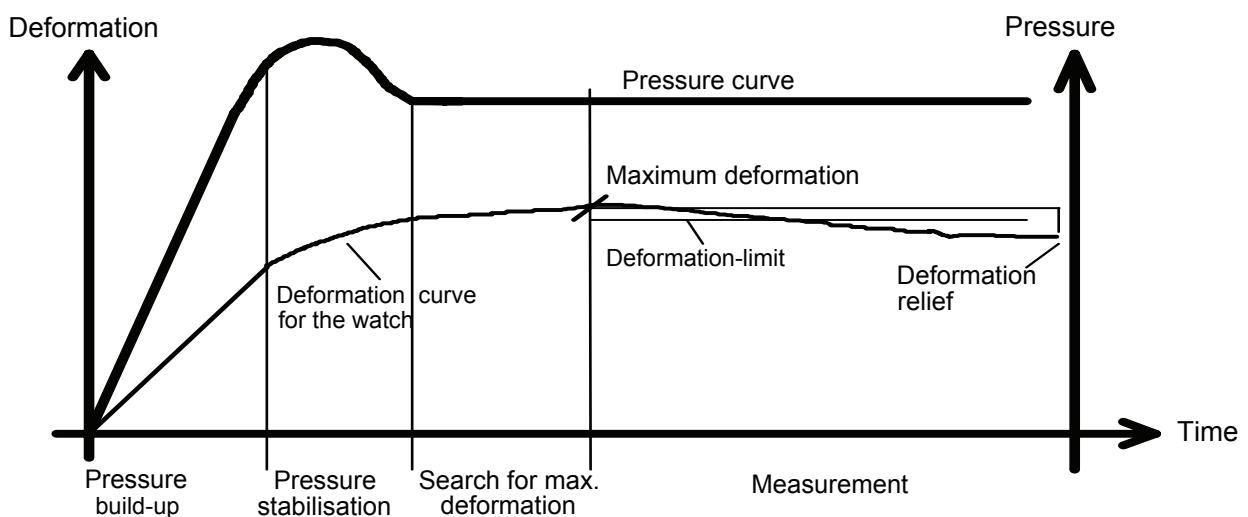

When a watch exhibits a plastic deformation (the deformation increases further after the test pressure has been reached), the unit waits for the maximum deformation to be reached after the stabilization period before the measurement is begun. The decision whether to classify the watch as **okay** or **rejected** is as described on page 29.

7.2 TABLE OF PRESSURES

This table indicates the forces, which are transmitted from the inside under vacuum and from the outside under pressure to the glass **and** to the back of the watch.

The forces are calculated as follows: **Force = P x 1.02 x R² x π** (1 bar = 1.02 kg/cm²)

Test under vacuum (bar)	Force from inside to the glass and back for Ø 30 mm (kg)
-0.2	1.44
-0.3	2.16
-0.4	2.88
-0.5	3.60
-0.6	4.33
-0.7	5.05
-0.8	5.77

Test under vacuum (bar)	Force from inside to the glass and back for Ø 25 mm (kg)
-0.2	1.00
-0.3	1.50
-0.4	2.00
-0.5	2.50
-0.6	3.00
-0.7	3.50
-0.8	4.01

Test under vacuum (bar)	Force from inside to the glass and back for Ø 20 mm (kg)
-0.2	0.64
-0.3	0.96
-0.4	1.28
-0.5	1.60
-0.6	1.92
-0.7	2.24
-0.8	2.56

Test under pressure (bar)	Force from outside to the glass and back for Ø 30 mm (kg)
0.2	1.44
0.3	2.16
0.4	2.88
0.5	3.60
0.6	4.33
0.7	5.05
0.8	5.77
0.9	6.49
1.0	7.21
1.2	8.65
1.4	10.09
1.6	11.53
1.8	12.98
2.0	14.42
2.5	18.02
3.0	21.63
3.5	25.23
4.0	28.84
4.5	32.44
5.0	36.05
6.0	43.26
7.0	50.47
8.0	57.68
9.0	64.89
10.0	72.10

Test under pressure (bar)	Force from outside to the glass and back for Ø 25 mm (kg)
0.2	1.00
0.3	1.50
0.4	2.00
0.5	2.50
0.6	3.00
0.7	3.50
0.8	4.00
0.9	4.51
1.0	5.01
1.2	6.01
1.4	7.01
1.6	8.02
1.8	9.02
2.0	10.02
2.5	12.52
3.0	15.02
3.5	17.52
4.0	20.03
4.5	22.53
5.0	25.03
6.0	30.04
7.0	35.05
8.0	40.06
9.0	45.06
10.0	50.07

Test under pressure (bar)	Force from outside to the glass and back for Ø 20 mm (kg)
0.2	0.64
0.3	0.96
0.4	1.28
0.5	1.60
0.6	1.92
0.7	2.24
0.8	2.56
0.9	2.88
1.0	3.20
1.2	3.84
1.4	4.48
1.6	5.12
1.8	5.76
2.0	6.40
2.5	8.01
3.0	9.61
3.5	11.22
4.0	12.82
4.5	14.42
5.0	16.02
6.0	19.23
7.0	22.43
8.0	25.64
9.0	28.84
10.0	32.04

VACUUM IN DEPENDENCE ON THE ALTITUDE

The generated vacuum can reach maximum 85% of the environment pressure. Following typical values result:

Altitude	Absolute Pressure	Maximum Vacuum
0 m	1.01 bar	-0.85 bar
500 m (1640 feet)	0.95 bar	-0.81 bar
1000 m (3281 feet)	0.90 bar	-0.76 bar
1500 m (4921 feet)	0.85 bar	-0.72 bar
2000 m (6562 feet)	0.79 bar	-0.68 bar

In practical operation and in dependence on the barometric pressure the obtained vacuum may vary a little.

8 TECHNICAL DATA

Measurement principle

- Analysis of the deformation of the watch casing under pressure and/or vacuum.

Fully automatic test program

1 Fixed measurement program

- Fixed test with vacuum and pressure: -0.2 / 2.0 bar.

Customer-specific test programs

- 10 test programs with adjustable pressures and measuring times. The limit tolerances for good/poor evaluations can be changed to suit special watches. Testing with vacuum, pressure or vacuum and pressure.

Vacuum and pressure

- Selectable vacuums from -0.2 to -0.8 bar in steps of -0.1 bar.
- Selectable pressures from 0.2 to 1.0 bar in steps of 0.1 bar, from 1.0 to 2.0 bar in steps of 0.2 bar, from 2.0 to 5.0 bar in steps of 0.5 bar and from 5.0 to 10 bar in steps of 1.0 bar.

Measurement times

- Automatic determination of the quickest necessary test time, or manual setting from 10 s up to 300 s.

Stabilization time

- Automatic transfer from the stabilization phase to the measurement phase once the necessary stability has been achieved.

Deformation measurement

- Absolute deformation from 0.0 to 999.0 μm (during the stabilization time).
- Relative deformation from 0.0 to 99.9 μm (during the measurement time).
- Internal resolution: 0.03 μm .

Evaluation and display

- Automatic tight/leaky evaluation.
- Good/poor indication by two-colored LED's.
- Indication of proper watch and sensor positioning by LED.
- Continuous display of the deformation, test pressure, stabilization and measuring time.
- Immediate indication and termination of the measurement if a leak is detected.
- The criteria for the good/poor evaluation (water-tightness tolerance) correspond closely to the ISO and NIHS standards for waterproof watches.

Special features

- Automatic closure of the chamber by a motor.
- Automatic opening of the chamber.
- RS 232 interface for printer connection or a PC.
- Text display in a choice of 9 languages.
- Only 4 operating buttons for all the functions.
- Programs remain stored in the event of a power failure.
- Hi-tech electronics with a 16-bit microprocessor.
- Sensor with quick adjustment for all types of casing, with and without a wrist-strap.

Casing

- Black lacquered hardwood frame, scratch proof aluminum front, back and base-plate.
- Cast aluminum chamber.
- Dimensions: 32 x 23 x 21.5 cm (d x w x h).
- Weight: 5.5 kg.

Compressed air connection

- Rapid action hose coupling for compressor or a compressed air hose.
- Maximum input pressure: 11 bar.

Mains

- Mains supply adapter, available for 230V~ or 120V~, 12VA.

Declaration of conformity

- The equipment is in conformity with the following EC-Directives:

89/336/EWG

EN 55011 : 1991

EN 50082-1 : 1992

EN 50082-2 : 1995

73/23/EWG

EN 61010 : 1993

89/392/EWG

EN 292 : 1991

EMC

Emissions

Immunity, public environments

Immunity, industry

Low voltage directive

Electrical safety

Machinery

Patents

- The equipment is protected by several patents.

9 ACCESSORIES

- Printer **CITIZEN CBM 910** (no graphic interface), available for 230 V~ only.
- Printer **CITIZEN DP-1014.0132A** graphic interface with universal mains adapter 90 V~ - 264 V~.
- Thermo Printer **Martel MCP9810**, available for 230 V~ or 120 V~.
- **Printer Switchbox** for connection of 2 equipments to the printer DP-1014.0132A.
- **Compressor JunAir 6-M** with stainless air reservoir 9.5 l. Pressure: 11 bar, available for 230 V~ or 120 V~.
- O-Ring for test chamber.

10 MAINTENANCE

10.1 CLEANING

- **ALC 2000**

Cleaning: remove the seal from the basic plate. Clean carefully from time to time the seal, the surface on the bottom side of the chamber and the seal groove on the basic plate by means of a smooth and dry cloth.

- **Compressor JunAir 6-M**

Oil level: check the oil level once a week. The oil level must be visible in the glass.

Removing moisture: blow down the reservoir at least once a week. Close it tightly after-wards. Please consult the enclosed User's Manual for further information.

Please consult the manual that goes with it if you are using another type of compressor.

For any questions please contact the customer service department at our head office or one of our representatives.

10.2 CALIBRATION

We recommend that the instrument should be calibrated and checked once a year to guarantee its measuring accuracy.

Please contact the customer service department at our head office or one of our representatives.