

PRESIDIUM[®]

Gem Computer Gauge | PGCG

USER HANDBOOK

Language Contents

- | | |
|---------------------|---------|
| 1. English Language | pg. 03 |
| 2. Chinese Language | pg. 35 |
| 3. French Language | pg. 66 |
| 4. German Language | pg. 102 |
| 5. Italian Language | pg. 139 |
| 6. Russian Language | pg. 176 |
| 7. Spanish Language | pg. 221 |

Contents

(English Version)

I. Disclaimers, Exclusions and Limitations of Liability	pg. 04
II. About this book	pg. 05
III. About your Presidium Gem Computer Gauge	pg. 06
IV. IMPORTANT NOTICE	pg. 10
1. GETTING STARTED with your Presidium Gem Computer Gauge	pg. 12
2. PERFORMING A TEST with your Presidium Gem Computer Gauge	pg. 13
a. Measurement	
b. Weight Estimator	
c. S.G. Dictionary	
d. Gemstone Estimator	
e. Calculator	
f. Inventory	
g. PC connectivity	
3. READING TEST RESULTS with your Presidium Gem Computer Gauge	pg. 32
4. TAKING CARE of your Presidium Gem Computer Gauge	pg. 34

I. Disclaimers, Exclusions and Limitations of Liability

PLEASE READ AND NOTE PRESIDIUM WARRANTY TERMS AND CONDITIONS as stated in the warranty card. Presidium warranty for its testers are subject to proper use by its users in accordance with all the terms and conditions as stated in the relevant user handbook and shall cover only manufacturing defects.

Due to continuous product improvement, Presidium reserves the right to revise all documents including the right to make changes to the handbook without notice and without obligation to notify any person of such revisions or changes. Users are advised to check Presidium's website <http://www.presidium.com.sg/> from time to time.

Presidium shall not be responsible for any damage or loss resulting from the use of this gauge or handbook, and under no circumstances shall Presidium, its manufacturer or any of its subsidiaries, licensors, distributors, resellers, servants and/or agents be liable for any direct or indirect damages, resulting from the use of this gauge.

TO THE MAXIMUM EXTENT PERMITTED BY APPLICABLE LAW, under no circumstances shall Presidium, its manufacturer or any of its subsidiaries, licensors, distributors, resellers, servants and/or agents be responsible for any special, incidental, consequential or indirect damages howsoever caused.

The gauge or Presidium Gem Computer Gauge (PGCG) referred to in this handbook is provided and/or sold on an "as is" basis. Except as required by applicable law, no warranties of any kind, either expressed or implied, including, but not limited to, the implied warranties of merchantability and fitness for a particular purpose.

II. About this book

Thank you for purchasing the Presidium Gem Computer Gauge (“PGCG” or “gauge”).

This handbook is designed to help you set up your gauge and describes all you need to know about how to use your gauge accurately and take care of it in line with its requirements. Please read these instructions carefully and keep them handy for future reference.

This book also contains the terms and conditions in relation to the use of the gauge including the **Disclaimer, Exclusion and Limitation of Liability clauses stated above in Section I.**

III. About your Presidium Gem Computer Gauge

The Presidium Gem Computer Gauge has been developed as an extension to the existing Presidium Electronic Gemstone Gauge with additional features to perform more functions, including:

- Measures actual gemstone dimensions and estimates gemstone weight and identity
- Measures 74 gemstones and 9 different shapes
- Accurate measurement up to 0.01mm
- Direct carat conversion for round brilliant cut diamonds
- Clear and visible display for ease of reading measurements
- Light and portable instrument that can be used anywhere
- PC connectivity for ease of importing and printing measurement results

Product specifications:

Measurement range: 0.00mm to 25.00mm or 0.000ct to 57.343ct

Recommended battery: CR 2450 3V or equivalent

Battery lifespan: generally about 26 hours of continuous usage

Included in your package:

- Presidium Gem Computer Gauge
- CR-2450 3V battery
- High setting jewelry attachment
- USB Cable
- User handbook
- Warranty card
- Protective box

Gauge parts

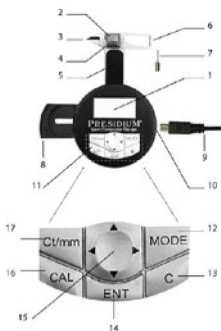

1	LCD Display
2	Base Anvil
3	Wedge-shaped Points
4	Slider
5	Slider Platform
6	Protruding Probe
7	Jewelry Attachment
8	Battery Compartment
9	USB Cable
10	USB Port
11	Selection Keypad
12	Mode Button
13	Clear Button
14	Enter Button
15	Navigation Button
16	Calculator Activation Button
17	Unit Conversion Button

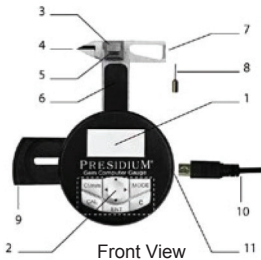

Display Configuration

The LCD display of PGCG is generally divided into three sections.

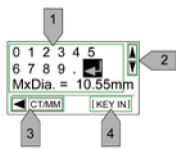

1. Interactive display
2. Scroll bar
3. Instruction bar

Keypad Configuration

Please refer to table below for the function of each key on the selection keypad. Some keys will have more than one function.

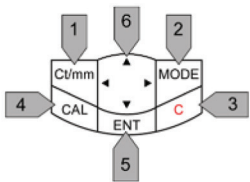

	Name	Normal Function	Additional Function
1	Carat ↔ mm	Press to change measurement unit between millimeter (mm) and carat (Ct)	In “Weight Estimator” and “Stone Estimator” mode, press to toggle between “Measurement” and “Keypad” to input dimension
2	Mode	Press to display the function selection menu	
3	Cancel	Press to delete items	<ul style="list-style-type: none"> • Press to turn on PGCG • In ‘Measurement’ mode, press for tare/zero function
4	Calculator	Press to activate calculator mode	In “Weight Estimator” mode, press for price calculation
5	Enter	Press to confirm selection	
6	Navigation keypad	Press to navigate data in interactive display	

IV. IMPORTANT NOTICE

- Keep the gauge dry. Precipitation and all types of liquids or moisture can contain minerals that will corrode electronic circuits. If your gauge does get wet, remove the battery, and allow the gauge to dry completely before replacing it.
- Do not use, store or expose the gauge in dusty and dirty areas. Its moving parts and electronic components can be damaged.
- Do not use, store or expose the gauge in hot areas. High temperatures can damage or shorten the life of tester, damage batteries, and warp or melt certain plastics.
- Do not use, store or expose the gauge in cold areas. When the tester returns to its normal temperature, moisture can form inside the tester and damage electronic circuit boards.
- Do not attempt to open the gauge other than as instructed in this handbook.
- Do not drop, knock, or shake the gauge. Rough handling might break internal circuit boards and fine mechanics.
- Do not use harsh chemicals, cleaning solvents, or strong detergents to clean the gauge.
- Do not paint the gauge. Paint can clog the moving parts and prevent proper operation.

If the gauge is not working properly, kindly contact Presidium Customer Service at service@presidium.com.sg or:

Presidium Instruments Pte Ltd
Unit 7, 207 Henderson Road
Singapore 159550
Attn: Customer Service Executive

1. GETTING STARTED with your Presidium Gem Computer Gauge

Inserting a battery into your Presidium Gem Computer Gauge

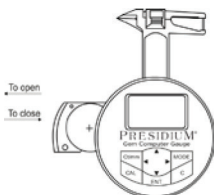

1. Pull the battery slider sideways outward using either fingernail or screw driver.
2. Place a CR 2450 3V battery with the (+) sign facing upward in the battery compartment and close by pushing the battery slider sideways inward.
3. The use of alkaline batteries is preferred, as it should generally give approximately two and a half hours of continuous operation, while the use of ordinary batteries will give a shorter working life.

Turning on your Presidium Gem Computer Gauge

1. Press the "C" button on the selection keypad.
2. The word "Presidium" will appear and the device will automatically go to "Measurement" mode.
3. The screen will display two lines; the first being measurement in millimeter unit and the second line being measurement in carat unit.

Please note that the PGCG will automatically shut down after 5 minutes of inactivity.

Battery information

Do not leave worn out batteries in the battery compartment as the batteries may corrode, leak or damage the gauge. Batteries should be removed when the instrument is expected to be stored for an extended period of time.

2. PERFORMING A TEST with your Presidium Gem Computer Gauge

1. By default, upon power up, the device will be in "Measurement" mode.
2. PGCG comes with the following functions:
 - a) Measurement
 - b) Weight Estimator
 - c) S.G. Dictionary
 - d) Gemstone Estimator
 - e) Calculator
 - f) Inventory
 - g) PC connectivity
3. To use other functions, press "Mode" on the selection keypad and choose a function from the list.

a. Measurement

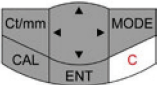
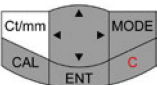
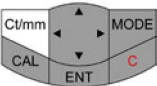
	Requirement	Activation Key	Display
1	<p>Upon turning on, PGCG will display dimension in mm and weight in Carat:</p> <p>1. Press "C" to turn on</p>		0.00 mm 0.000 ct
2	<p>For display of dimension in mm only:</p> <p>1. Press "Ct/mm"</p>		0.00 mm
3	<p>For display of weight in Carat only:</p> <p>1. Press "Ct/mm"</p>		0.000 ct

- The Presidium Gem Computer Gauge should be held in the palm of either hand. Control the slider with the thumb.



- When measuring loose stones, pull the Slider and place the stone on the Slider platform. The base of the stone should be parallel to the platform to prevent it from moving.

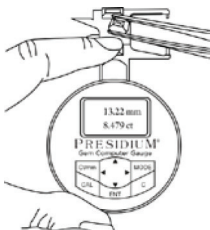

- When measuring mounted stones, insert the jewelry attachment to the gauge and place the stone between the jewelry attachment and slider anvil.



- Slowly close the Slider. The reading will be displayed on the window immediately.



- Press “ct/mm” to alternate between the following displays:
 1. Display of both dimension in mm and weight in carat (by default)
 2. Display of dimension in mm only
 3. Display of weight in carat only

The default setting of Presidium Gem Computer Gauge (PGCG) is programmed for American Standard Round Brilliant Cut



For other gemstones of other shapes, please directly proceed to the following steps.





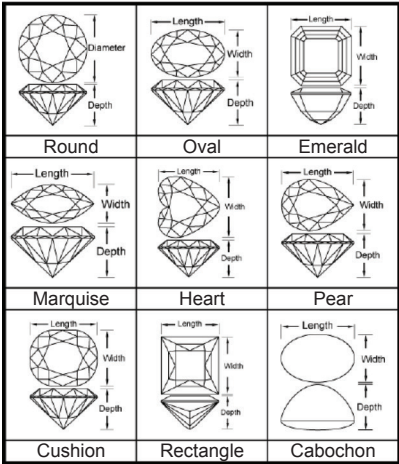

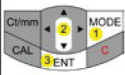
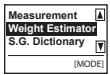
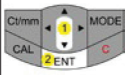
b. Weight Estimator





Presidium Gem Computer Gauge (PGCG) estimates the weight of the gemstone from the shape, diameter, depth and nature of the gemstone.

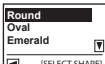
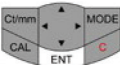

The different shapes of gemstones as shown in diagram below:

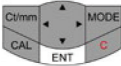
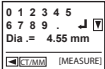
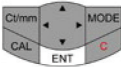
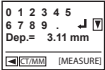

	Requirement	Activation Key	Display
1.	<ul style="list-style-type: none"> ⊖ Select Weight Estimator: Select Mode ⊖ Scroll to Weight Estimator ⊗ Press “ENT” to confirm 		
2.	<ul style="list-style-type: none"> ⊖ Select New or Previous Setting: Scroll to select ⊖ Press “ENT” to confirm 		

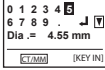
<p>3.1 New Settings</p>	<p>Select Gem stone name:</p> <ul style="list-style-type: none"> ⊖ Scroll to select gemstone name by the first alphabet. ⊖ Press “ENT” to confirm 		
	<p>Select a Gem stone:</p> <ul style="list-style-type: none"> ⊖ Scroll to select ⊖ Press “ENT” to confirm 		
	<ul style="list-style-type: none"> ⊖ Select a Shape: Scroll to select ⊖ Press “ENT” to confirm <p>Note: The different dimensions to be input depend on the shape of the gemstone. Please refer to Page 16 for shape and their respective dimensions required.</p>		
<p>3.2 Previous Settings</p>	<p>Setting of previous gemstone will be displayed:</p> <ul style="list-style-type: none"> • Press “ENT” to confirm 		

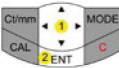
4	<p>Select method of measurement:</p> <ul style="list-style-type: none"> ⊖ Scroll to select from measurement or keypad ⊖ Press “ENT” to confirm 		
4.1 Measurement	<p>Measurement of Diameter:</p> <ul style="list-style-type: none"> • Place gem stone's diameter on base anvil • Press “ENT” to confirm 		
	<p>Measurement of Depth:</p> <ol style="list-style-type: none"> 1. Place gem stone's depth on base anvil 2. Press “ENT” to confirm 		
4.2 Keypad	<p>Keying of Diameter:</p> <ul style="list-style-type: none"> ⊖ Key in gem stone's diameter ⊖ To confirm entry, navigate ← cursor to and press “ENT” 		

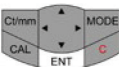
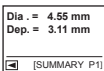
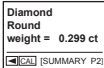
	<p>Keying of Depth:</p> <ul style="list-style-type: none"> ⊖ Key in gem stone's depth ⊖ To confirm entry, navigate cursor to ← and press "ENT" <p>Please note that at any point, pressing Ct/mm will toggle between "Keypad" or "Measurement" input methods</p>		
<p>5.</p>	<p>Summary of gemstone's diameter and depth.</p> <ul style="list-style-type: none"> • Press "ENT" to confirm 		
<p>6.</p>	<p>Estimated weight of gemstone will be displayed. At this point, user can either press "Ent" to store or "Cal" for price calculation. Details will be given in 6.1 and 6.2 below</p>		

6.1 Storing Data

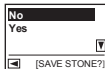
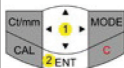

Storing of data into inventory:

- ⊖ Press “ENT” to store data
- ⊖ Scroll to select “YES/NO”

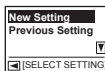
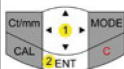

- ⊖ If user selects “NO”, display will return to “Select Setting” for next measurement. User will have the liberty to choose between previous or new stones setting.
- ⊖ Press “ENT” to confirm

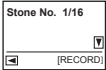
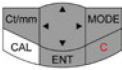

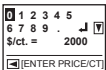
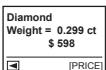
<p>6.1 Storing Data</p>	<p>⊖ If user selects “YES”, details of gemstone will be stored in “Inventory”</p> <p>⊖ Press “ENT” to confirm</p> <p>Upon storing of data, display will return to “Select Setting” for next measurement. User will have the liberty to choose between previous or new stones setting.</p>		
<p>6.2 Price Calculation</p>	<p>Price calculation of gemstone:</p> <ul style="list-style-type: none"> • Press “CAL” 		
<p>⊖ Keying of price: For data entry, navigate cursor to ← selected data and press “ENT”</p> <p>⊖ To confirm price per carat, navigate cursor to and press “ENT”</p>			
<p>Price of gemstone will be displayed</p>			

6.2 Price Calculation

Storing of data into inventory:

- Press “ENT” to store data
- Scroll to select “YES” in option to store
- Press “ENT” to confirm
- Upon storing of data, display will return to “Select Setting” for next measurement

Please note only the settings of the stone are stored. Storing function is similar to section 6.1 above. Price of the gemstone will not be stored.

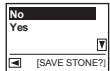
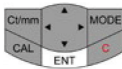

c. Specific Gravity (S.G.) Dictionary

Presidium Gem Computer Gauge enables the narrowing down of a gemstone by its S.G. Presidium Gem Computer Gauge (PGCG) includes a dictionary for S.G. values of selected gemstones for your reference.

Please note that the weight of gemstone will be needed from other source for the identification of gemstone.



	Requirement	Activation Key	Display
1.	<p>Select S.G. Dictionary:</p> <ul style="list-style-type: none"> ⊖ Select Mode ⊖ Scroll to S.G. Dictionary ⊗ Press “ENT” to confirm 		
2.	<p>Select Gem stone name:</p> <ul style="list-style-type: none"> ⊖ Scroll to select gemstone name by the first alphabet ⊖ Press “ENT” to confirm 		
3.	<p>Select Gem stone:</p> <ul style="list-style-type: none"> ⊖ Scroll to select ⊖ Press “ENT” to confirm 		



4.	S.G. value of selected gemstone will be displayed		<div data-bbox="733 98 936 228" style="border: 1px solid black; padding: 5px;"> Diamond S.G. = 3.52 3.51 - 3.53 ▼ ◀ [S.G. VALUE] </div>
----	---	--	---



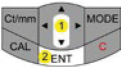
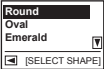

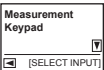
d. Gemstone Estimator

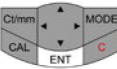
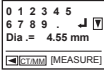
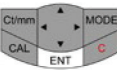
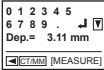
In order to determine the S.G. of the gemstone to be tested:

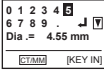
	Requirement	Activation Key	Display
1.	<ul style="list-style-type: none"> ⊖ Select Gem stone Estimator: ⊖ Select Mode ⊗ Scroll to Gem stone Estimator <p>Press "ENT" to confirm</p>		<div data-bbox="728 840 930 966" style="border: 1px solid black; padding: 5px;"> Weight Estimator ▲ S.G. Dictionary Gemstone Estimator ▼ [MODE] </div>

<p>2.</p> <p>Select a Shape³:</p> <ul style="list-style-type: none"> ⊖ Scroll to select ⊖ Press “ENT” to confirm <p>³ Please refer to Page 16 for the picture illustrations of the shapes.</p> <p>⁴ The different dimensions to be input depend on the shape of the gemstone. Please refer to Page 16 for different shapes and their respective dimensions required.</p>			
<p>3.</p> <p>Select method of measurement:</p> <ul style="list-style-type: none"> ⊖ Scroll to select from measurement or keypad ⊖ Press “ENT” to confirm 			



3.1 Measurement 4	<p>Measurement of Diameter</p> <ul style="list-style-type: none"> Place gem stone's diameter on base anvil Press "ENT" to confirm 		
	<p>Measurement of Depth:</p> <ul style="list-style-type: none"> Place gem stone's depth on base anvil Press "ENT" to confirm 		
3.2 Keypad	<p>Keying of Diameter:</p> <ul style="list-style-type: none"> ⊖ Key in gem stone's diameter ⊖ To confirm entry, navigate cursor to ↵ and press "ENT" 		

<p>3.2 Keypad</p>	<p>Keying of Depth:</p> <ul style="list-style-type: none"> ⊖ Key in gem stone's depth ⊖ To confirm entry, navigate cursor to ↵ and press "ENT" <p>Please note that at any point, pressing Ct/mm will toggle between "Keypad" or "Measurement" input methods</p>		
<p>4</p>	<p>Keying of weight:</p> <ul style="list-style-type: none"> ⊖ Key in gem stone's weight ⊖ To confirm entry, navigate cursor to ↵ and press "ENT" 		

5	<p>S.G. value of gemstone will be calculated. List of gemstones⁵ with associated SG value will be displayed</p> <p>⁵ Please refer to Page 32-33 for the list of gemstones included in PGCG</p>		
---	--	--	--

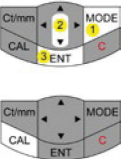
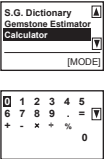

e. Calculator

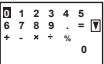



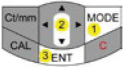
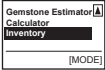
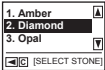

Presidium Gem Computer Gauge (PGCG) also allows you to do simple calculations.

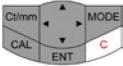

	Requirement	Activation Key	Display
1.	<p>Select Calculator:</p> <ul style="list-style-type: none"> ⊖ Select Mode ⊖ Scroll to Calculator ⊗ Press “ENT” to confirm Alternatively, press “CAL” to select Calculator 		
2.	<p>Calculation:</p> <ul style="list-style-type: none"> • For data entry, navigate cursor to selected data and press “ENT” 		

f. Inventory

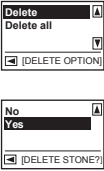
Presidium Gem Computer Gauge (PGCG) allows you to store details (e.g., identify of gemstone, shape, and weight) of gemstones for reference.

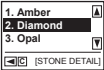
	Requirement	Activation Key	Display
1.	<p>Select Inventory:</p> <ul style="list-style-type: none"> ⊖ Select Mode ⊖ Scroll to Inventory ⊗ Press “ENT” to confirm 		
2.	<p>All gem stones stored in memory will be listed</p>		
3.	<p>Select gem stone's details:</p> <ul style="list-style-type: none"> ⊖ Scroll to select ⊖ Press “ENT” to confirm 		

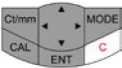
<p>4</p> <p>Deletion of selected gemstone's details:</p> <ul style="list-style-type: none"> ⊖ Scroll to selected gemstone record that you want to delete ⊖ Press "ENT" to confirm 		
<ul style="list-style-type: none"> • Press "C" to delete 		
<ul style="list-style-type: none"> ⊖ Select "Delete" from deletion option and press "ENT" to confirm ⊖ Select "Yes" and press "ENT" to confirm 		
<p>Deletion of all gemstone's details:</p> <ul style="list-style-type: none"> ⊖ Scroll to any gemstone record ⊖ Press "ENT" to confirm 		

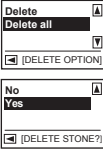
<ul style="list-style-type: none"> • Press “C” to delete 		
<ul style="list-style-type: none"> ⊖ Select “Delete All” from deletion option and press “ENT” to confirm ⊖ Select “Yes” and press “ENT” to confirm 		

g. PC Connectivity

The Presidium Gem Computer Gauge comes with a downloadable software providing access to more gemstones selection. Go to www.presidium.com.sg



This software is currently not yet compatible with Mac OS platform.

3. READING TEST RESULTS with your Presidium Gem Computer Gauge

The S.G. values for the following gemstones are stored in Presidium Gem Computer Gauge:

Common stones (in alphabetical order)	
Albite feldspar	Nephrite
Alexandrite	Obsidian
Almandite garnet	Oligoclase feldspar
Amber	Opal
Andalusite	Orthoclase
Andradite garnet	Pearl
Apatite	Peridot
Benitoite	Plastic
Beryl	Pyrope garnet
Brazilianite	Quartz
Calcite	Rhodochrosite
Chalcedony	Rhodolite garnet
Coral	Rhodonite
Corundum	Sapphire
Cubic zirconium oxide	Scapolite
Diamond	Serpentine
Danburite	Shell
Diopside	Sinhalite
Diophtase	Sodalite
Fluorite	Sopodumene
Glass	Spessartite garnet
G.G.G.	Sphene
Hematite	Spinel
Idocrase	Strontium titanate

Iolite	Synthetic emerald
Ivory	Synthetic rutile
Jadeite	Synthetic spinel
Jet	TL grossularite garnet
Kornerupine	Topaz
Kyanite	Tourmaline
Labradorite feldspar	TP grossularite garnet
Lapis lazuli	Turquoise
Moissanite	Verdite
Malachite	Y.A.G
Microcline	Zircon (high)
Moldavite	Zircon (low)
	Zircon (medium)
	Zoisite

4. TAKING CARE of your Presidium Gem Computer Gauge

- Do not leave worn out batteries in the battery compartment as the batteries may corrode, leak or damage the gauge. Batteries should be removed when the gauge is expected to be stored for an extended period of time.

Your gauge is a product of extensive design and craftsmanship and should be treated with care.

Thank you for taking time to go through the user handbook which will enable you to understand your recent purchase better.

Presidium also recommends that you register your warranty by sending the warranty registration card to us or register online at <http://www.presidium.com.sg/>

Presidium 宝石电脑 量规 (PGCG) 用户手册

目录

(Chinese Version)

I. 关于本手册	pg. 37
II. 关于 Presidium 宝石电脑量规	pg. 38
III. 重要说明	pg. 42
1. 开始使用 Presidium 宝石电脑量规	pg. 43
2. 使用 Presidium 宝石电脑量规 执行检测	pg. 44
a. 测量	
b. 重量估算器	
c. S.G. 目录	
d. 宝石估算器	
e. 计算器	
f. 清单	
g. PC 连接	
3. 使用 Presidium 宝石电脑量规 读取检测结果	pg. 63
4. 维护 Presidium 宝石电脑量规	pg. 65

I. 关于本手册

感谢您选购 Presidium 宝石电脑量规（简称“PGCG”或“量规”）。

本手册旨在帮助您设置量规，并且将介绍关于如何正确地使用您的量规及按照要求对其进行护理所有您所需要的知识。请仔细阅读这些说明，将其放在方便之处以便将来参考。

II. 关于 Presidium 宝石电脑量规

Presidium 宝石电脑量规是作为现有 Presidium 电子宝石量规而研制的扩展件，增加了一些特性以执行更多功能，包括：

- 测量实际宝石尺寸和估算宝石重量及品种
- 可测量 74 种宝石和 9 种不同形状
- 测量精度高达 0.01mm
- 对于圆形明亮型切割钻石可直接换算克拉重量
- 清晰的显示屏，便于读取测量结果
- 仪器轻便易携，可在任何地方使用
- 可连接 PC，方便导入和打印测量结果

产品规格：

测量范围：0.00mm 至 25.00mm 或 0.000ct 至 57.343ct

建议使用的电池：CR 2450 3V 或同类产品

电池寿命：通常可连续使用约 26 小时

包装物品：

- Presidium 宝石电脑量规
- CR-2450 3V 电池
- 高镶托珠宝夹具
- USB 线
- 用户手册
- 质保卡
- 保护盒

量规零件

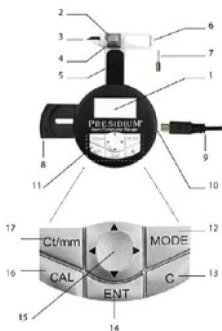

1	LCD 显示屏
2	基准测量头
3	楔形尖头
4	游标
5	游标平台
6	探针
7	珠宝夹具
8	电池仓
9	USB 线
10	USB 端口
11	选择键台
12	模式按钮
13	清除按钮
14	确认按钮
15	导航按钮
16	计算器激活按钮
17	单位换算按钮

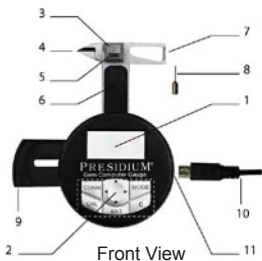

显示屏配置

PGCG 的液晶屏显示屏通常分为三部分。

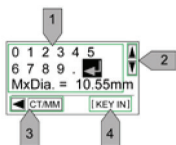

1. 交互显示
2. 滚动滚动条区域
3. 说明栏

键台配置

请参阅下表，了解选择键台上每个键的功能。有些键有多项功能。

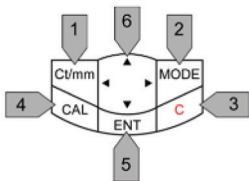

	名称	标准功能	附加功能
1	克拉 t ↔ 毫米	按此键可使测量单位在毫米 (mm) 和克拉 (Ct) 之间转换	在“重量估算器”和“宝石估算器”模式下, 按此键可在“测量”和“键台”之间切换以输入的尺寸
2	模式	按此键可显示功能选择菜单	
3	取消	按此键可删除项目	<ul style="list-style-type: none"> • 按此键可打开 PGCG • 在“测量”模式下, 按此键可执行归零功能
4	计算器	按此键可激活计算器模式	在“重量估算器”模式下, 按此键可进行价格计算
5	确认	按此键可确认选择	
6	导航键台	按此键可在交互显示屏中导航数据	

III. 重要说明

- 保持量规干燥。雨水以及任何形式的液体或湿气均可能含有对电子线路具有腐蚀性的矿物质。如果量规被打湿，请取出电池，让量规彻底晾干，如仍然故障 则需更换设备。
- 切勿在多灰尘和脏乱的环境中使用、存放或暴露量规。这有可能损坏其活动部件或电子元件。
- 切勿在高温环境中使用、存放或暴露量规。高温有可能损坏或缩短检测仪的寿命、损伤电池以及使某些塑料部件变形或熔化。
- 切勿在低温环境中使用、存放或暴露量规。当检测仪回到正常温度时可能在仪器内部形成湿气，从而对电子电路板造成损害。
- 切勿尝试通过本手册中的方法来打开量规。
- 切勿跌落、撞击或摇晃量规。粗暴地使用可能导致内部电路板和精密构造。
- 切勿使用刺激性化学物质、清洁溶剂或强力洗涤剂来清洗量规。
- 切勿给量规上漆。油漆可能会阻塞活动部件，并妨碍其正常工作。

如果量规无法正常工作，请通过以下方式联系 Presidium 客户服务部门 - 电子邮件：service@presidium.com.sg 或者寄信至：

Presidium Instruments Pte Ltd
Unit 7, 207 Henderson Road
Singapore 159550
Attn: Customer Service Executive

1. 开始使用 Presidium 宝石电脑量规

在 Presidium 宝石电脑量规中装入电池

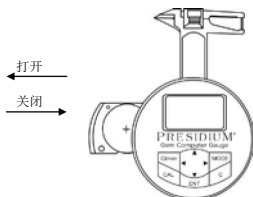

1. 使用指甲或螺丝刀将电池滑架侧缘向外拉出。
2. 将 CR 2450 3V 电池 (+) 记号朝上放入电池仓，然后将电池滑架侧缘推入以关闭电池仓。
3. 推荐使用碱性电池，因为它一般可以保证约 2.5 个小时的持续工作时间，而使用普通电池的话其工作时间较短。

关于 Presidium 宝石电脑量规

1. 按选择键台上的“C”按钮。
2. 将显示“Presidium”字样，而设备将自动转到“测量”模式。
3. 屏幕将显示两行；第一行是以毫米为单位的测量结果，第二行是以克拉为单位的测量结果。

请注意，PGCG 将在连续 5 分钟不工作后将自动关闭。

电池信息

切勿将用完的电池留在电池仓内，因为电池电解液可能发生泄露，从而腐蚀或损坏量规。如果预计要将仪器存放较长时间，应取出电池。

2. 用 Presidium 宝石电脑量规执行检测

1. 默认情况下，设备在通电后将进入“测量”模式。
2. PGCG 提供以下功能：
 - a) 测量
 - b) 重量估算器
 - c) S.G. 目录
 - d) 宝石估算器
 - e) 计算器
 - f) 清单
 - g) PC 连接
3. 要使用其他功能，请按选择键台上的“Mode”，然后从列表选择功能。

a. 测量

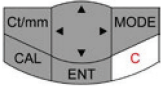
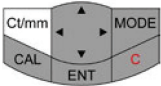
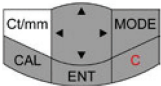
	操作要求	激活键	显示
1	在开机时，Presidium 宝石电脑量规 将显示以毫米为单位的尺寸和以克拉为单位的重量： 1. 按“C”开机		0.00 mm 0.000 ct
2	用于仅显示以毫米为单位的尺寸： 1. 按“Ct/mm”		0.00 mm
3	用于 要仅显示以克拉为单位的重量： 1. 按“Ct/mm”		0.000 ct

- 应该用任一手的手掌握持 Presidium 宝石电脑规。用拇指操作游标。

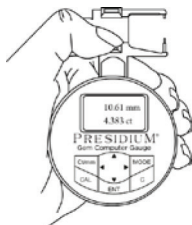

- 测量裸石时，应拨动游标，将宝石放在游标平台上。宝石的底面应该与平台平行，以防宝石移动。

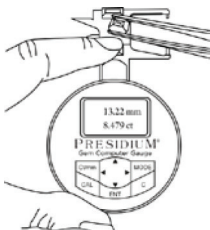

- 测量已镶嵌的宝石时，请将珠宝夹具插在量规上，然后将宝石夹在珠宝夹具和游标测量头之间。



- 慢慢合上游标。读数将立即显示在窗口上。

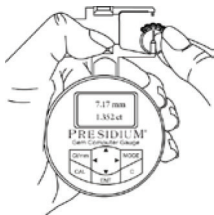

- 按下“ct/mm”会在以下显示内容之间切换：
 1. 显示以毫米为单位的尺寸和以克拉为单位的重量（默认）
 2. 仅显示以毫米为单位的尺寸
 3. 仅显示以克拉为单位的重量

Presidium 宝石电脑量规 (PGCG) 的默认设置是针对美国标准圆形明亮型切割编程的



对于其他形状的宝石，请直接执行以下步骤。





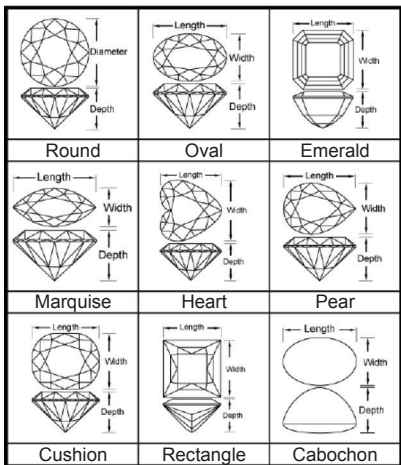

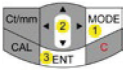
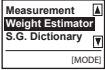
b. 重量估算器





Presidium 宝石电脑量规 (PGCG) 可根据宝石的形状、直径、高度和性质估算宝石的重量。

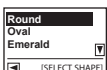
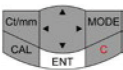

不同的宝石形状如下表所示：

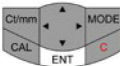
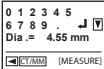
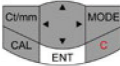
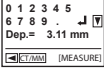

	操作要求	激活键	显示
1.	选择 Weight Estimator: ⊖ 选择 Mode ⊖ 滚动至 Weight Estimator ⊗ 按“ENT”确认		
2.	选择 New Setting 或 Previous Setting: ⊖ 滚动进行选择 ⊖ 按“ENT”确认		

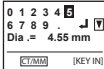
<p>3.1 New Settings</p>	<p>选择宝石名称：</p> <ul style="list-style-type: none"> ⊖ 滚动以按首字母排列的宝石名称。 按“ENT” ⊖ 确认 		
	<p>选择宝石：</p> <ul style="list-style-type: none"> ⊖ 滚动进行选择 ⊖ 按“ENT”确认 		
	<p>选择形状：</p> <ul style="list-style-type: none"> ⊖ 滚动进行选择 ⊖ 按“ENT”确认 <p>注意：要输入的不同尺寸取决于宝石的形状。请参阅第47页，了解形状及其各自所需的尺寸。</p>		
<p>3.2 Previous Settings</p>	<p>显示上一宝石的设置：</p> <ul style="list-style-type: none"> • 按“ENT”确认 		

4	<p>选择测量方法：</p> <ul style="list-style-type: none"> ⊖ 滚动以选择 measurement 或 keypad ⊖ 按“ENT” <p>确认</p>		
4.1 Measurement	<p>测量直径：</p> <ul style="list-style-type: none"> • 将宝石沿直径方向放在基准测量头上 • 按“ENT”确认 		
	<p>测量高度：</p> <ol style="list-style-type: none"> 1. 将宝石沿高度方向放在基准测量头上 2. 按“ENT”确认 		
4.2 Keypad	<p>键入直径：</p> <ul style="list-style-type: none"> ⊖ 键入宝石的直径 <p>将光标导航至 ← 并按“ENT”，以确认键入的内容。</p>		

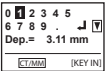
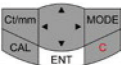
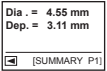
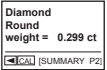
	<p>键入高度：</p> <ul style="list-style-type: none"> ⊖ 键入宝石的高度 ⊖ 将光标导航至， <p>并按“ENT” 请注意，任何时候按 Ct/mm 都会在“键台”和“测量”输入方法之间切换</p>		
5.	<p>宝石的直径和高度总结。</p> <ul style="list-style-type: none"> • 按“ENT”确认 		
6.	<p>将显示宝石的估算重量。此时，用户可以按“Ent”存储或按“Cal”计算价格。在下文的6.1和6.2中将提供详细信息</p>		

6.1 Storing Data



将数据存储到清单中：

- ⊖ 按“ENT”存储数据
- ⊖ 滚动以选择“YES/NO”

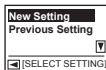

- ⊖ 如果用户选择“NO”，显示屏将返回到“Select Setting”以便进行下一次测量。用户将可以自由选择上次的设置或新宝石设置。
- ⊖ 按“ENT”确认

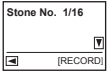
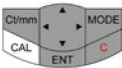

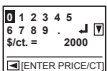
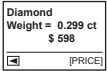
6.1 Storing Data	<ul style="list-style-type: none"> ⊖ 如果用户选择“YES”，宝石的详细信息将存储在“Inventory”中 ⊖ 按“ENT”确认 <p>在存储数据时，显示屏将返回到“Select Setting”以便进行下一次测量。用户可以自由选择上次的设置或新宝石设置。</p>		
6.2 Price Calculation	<p>算宝石的价格计算：</p> <ul style="list-style-type: none"> • 按“CAL” 		
	<p>键入价格：</p> <ul style="list-style-type: none"> ⊖ 要输入数据，将光标导航到 ← 选定数据并按“ENT” ⊖ 要确认每克拉价格，将光标导航到位并按“ENT” 		
	<p>将显示宝石的价格</p>		

将数据存储到清单中：

- 按“ENT”存储数据
- 滚动以在选项中选择“YES”存储
- 按“ENT”确认
- 在存储数据时，显示屏将返回到“Select Setting”以便进行下一次测量



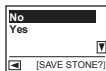
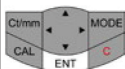

请注意，仅存储宝石的设置。存储功能类似于上文的第6.1节。将不存储宝石的价格。

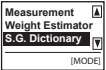

c. S.G. 目录

Presidium 宝石电脑量规可根据 S.G 确定宝石的具体品种。Presidium 宝石电脑量规 (PGCG) 包含用于选择宝石种类的 S.G. 值的目录供您参考。

请注意，要鉴定宝石，需要由其他来源提供的宝石重量。

	操作要求	激活键	显示
1.	<p>选择 S.G. Dictionary:</p> <ul style="list-style-type: none"> ⊖ 选择 Mode ⊖ 滚动至 S.G. Dictionary ⊗ 按“ENT”确认 		
2.	<p>选择宝石名称:</p> <ul style="list-style-type: none"> ⊖ 滚动以选择按首字母排列的宝石名称 ⊖ 按“ENT”确认 		
3.	<p>选择宝石:</p> <ul style="list-style-type: none"> ⊖ 滚动进行选择 ⊖ 按“ENT”确认 		

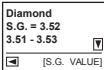

4.	将显示所选宝石的 S.G. 值		
----	-----------------	--	--

d. 宝石估算器

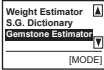

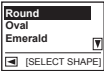
要确定受测宝石的 S.G. :

	操作要求	激活键	显示
1.	选择 Gem stone Estimator: ⊖ 选择 Mode ⊖ 滚动至 Gemstone ⊗ Estimator 按“ENT”确认		

<p>2.</p>	<p>选择形状³:</p> <ul style="list-style-type: none"> ⊖ 滚动进行选择 ⊖ 按“ENT”确认 <p>³请参阅第47页，查看各种形状的配图。</p> <p>⁴要输入的不同尺寸取决于宝石的形状。请参阅第47页，了解不同形状及其各自所需的尺寸。</p>		
-----------	--	---	--

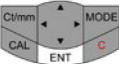
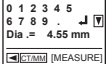
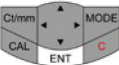
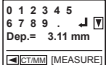
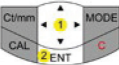
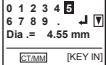
<p>3.</p>	<p>选择测量方法:</p> <ul style="list-style-type: none"> ⊖ 滚动以选择 measurement 或 keypad ⊖ 按“ENT”确认 		
-----------	---	--	--

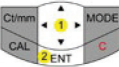

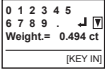
<p>3.1 Measurement 4</p>	<p>测量直径：</p> <ul style="list-style-type: none"> • 将宝石沿直径方向放在基准测量头上 • 按“ENT”确认 		
	<p>测量高度：</p> <ul style="list-style-type: none"> • 将宝石沿高度方向放在基准测量头上 • 按“ENT”确认 		
<p>3.2 Keypad</p>	<p>键入直径：</p> <ul style="list-style-type: none"> ⊖ 键入宝石的直径 ⊖ 要确认键入内容，将光标导航至 ← 并按“ENT” 		

<p>3.2 Keypad</p>	<p>键入高度：</p> <ul style="list-style-type: none"> ⊖ 键入宝石的高度 ⊖ 要确认键入内容，将光标导航至 ← 并按“ENT” <p>请注意，任何时候按 Ct/mm 都会在“键盘”和“测量”输入方法之间切换</p>		
<p>4</p>	<p>键入重量：</p> <ul style="list-style-type: none"> ⊖ 键入宝石的重量 ⊖ 要确认键入内容，将光标导航到位并按“ENT” 		

5	<p>将计算所选宝石的 S.G. 值将显示与 SG 值相关的宝石列表。</p> <p>⁵请参阅第63-64页，以查看 PGCG 中包含的宝石列表</p>		
---	---	--	--



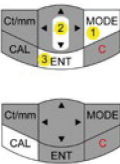
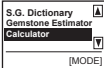
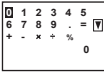

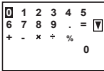
e. 计算器





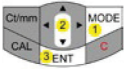
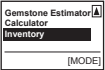

Presidium 宝石电脑量规 (PGCG) 还允许您进行简单计算。

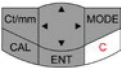

	操作要求	激活键	显示
1.	<p>选择 Calculator:</p> <ul style="list-style-type: none"> ⊖ 选择 Mode ⊖ 滚动至 Calculator ⊗ 按“ENT”确认 或者，按“CAL”选择计算器 		 
2.	<p>计算:</p> <ul style="list-style-type: none"> • 要输入数据，导航光标以选择数据并按“ENT” 		

f. 清单

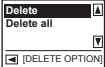
Presidium 宝石电脑量规 (PGCG) 允许您存储宝石的详细信息 (例如宝石的品种、形状和重量) 供以参考。

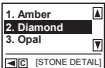
	操作要求	激活键	显示
1.	选择 Inventory: ⊖ 选择 Mode ⊖ 滚动至 Inventory ⊗ 按“ENT”确认		
2.	将列出存储器中存储的所有宝石		
3.	选择宝石的详细信息: ⊖ 滚动进行选择 ⊖ 按“ENT”确认		

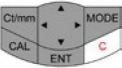
<p>4</p>	<p>删除所选宝石的详细信息:</p> <ul style="list-style-type: none"> ⊖ 滚动至要删除的宝石记录 ⊖ 按“ENT”确认 		
	<ul style="list-style-type: none"> • 按“C”删除 		
	<ul style="list-style-type: none"> ⊖ 从删除选项中选择“Delete”并按 ⊖ “ENT”确认选择“YES”并按“ENT”确认 		 
	<p>删除所有宝石的详细信息:</p> <ul style="list-style-type: none"> ⊖ 滚动至任何宝石记录 ⊖ 按“ENT”确认 		

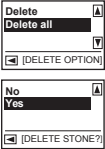
<ul style="list-style-type: none"> 按“C”删除 		
<ul style="list-style-type: none"> 从删除选项中选择“Delete All”并按 “ENT”确认选择“YES”并按“ENT”确认 		

g. PC 连接

Presidium Gem Computer Gauge配有可下载的软件，提供更多宝石选项。请点击www.presidium.com.sg

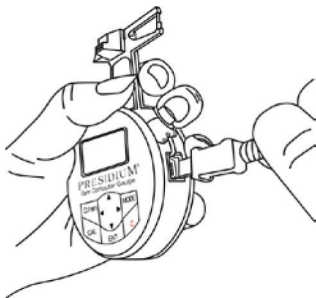

本软件目前还不能与 Mac OS 平台兼容。

3. 用 Presidium 宝石电脑量规读取检测结果

Presidium 宝石电脑量规中存储了以下宝石的S. G. 值:

常见宝石 (按字母顺序排列)	
钠长石	软玉
紫翠玉	黑曜石
贵榴石	奥长石
琥珀	欧泊
红柱石	正长石
钙铁榴石	珍珠
磷灰石	橄榄石
蓝锥矿	塑料
绿	镁铝榴石
磷铝钠石	石英
方解石	菱锰矿
玉髓	玫瑰榴石
珊瑚	蔷薇辉石
刚玉	蓝宝石
立方氧化锆	方柱石
钻石	蛇纹石
赛黄晶	贝壳
透辉石	硼铝镁石
透视石	方钠石
萤石	锂辉石
玻璃	锰铝榴石
钷、镓、石榴石	楣石
赤铁矿	尖晶石
符山石	钛酸锶

堇青石	钛酸锶
象牙	人造翡翠
硬玉	人造金红石
煤玉	人造尖晶石
柱晶石	TL 钙铝榴石
蓝晶石	黄玉
闪光拉长石	电气石
天青石	TP 钙铝榴石
孔雀石	绿松石
微斜长石	铬云母
莫尔道熔融石	钇铝石榴石
	锆石（高）
	锆石（低）
	锆石（中）
	黝帘石

4. 维护 Presidium 宝石电脑量规

- 切勿将用完的电池留在电池仓内，因为电池电解液可能发生泄露，从而腐蚀或损坏量规。如果预计要将量规存放较长时间，应取出电池。

您的量规是精心设计、精工制造的产品，应小心使用。

感谢您抽出时间阅读本用户手册，它会让您更好地了解您新购买的产品。

Presidium 还建议您完成质保注册流程，可以通过将质保注册卡寄送给我们，也可以通过 <http://www.presidium.com.sg/> 在线注册来完成注册。

**Manuel de l'utilisateur
pour la jauge
d'ordinateur de
gemmes Presidium
(PGCG)**

Table des matières

(French Version)

I. À propos de ce manuel	pg. 68
II . À propos de votre jauge d'ordinateur de gemmes Presidium	pg. 69
III. AVIS IMPORTANT	pg. 73
1. PREMIÈRE UTILISATION de votre jauge d'ordinateur de gemmes Presidium	pg. 75
2. EFFECTUER UN TEST avec votre jauge d'ordinateur de gemmes Presidium	pg. 76
a. Mesures	
b. Évaluation du poids	
c. Dictionnaire des densités	
d. Évaluation de gemmes	
e. Calculateur	
f. Inventaire	
g. Connectivité avec PC	
3. LIRE LES RÉSULTATS DE TEST sur votre jauge d'ordinateur de gemmes Presidium	pg. 99
4. PRENDRE SOIN de votre jauge d'ordinateur de gemmes Presidium	pg. 101

I. À propos de ce manuel

Nous vous remercions d'avoir acheté le jauge d'ordinateur de gemmes Presidium « PGCG » ou « Testeur »

Ce manuel est conçu pour vous aider à configurer votre testeur et décrit tout ce que vous devez savoir sur la façon de l'utiliser de façon précise et d'en prendre soin conformément aux besoins. Veuillez lire ces instructions attentivement et les conserver pour toute référence future.

II. À propos de votre Jauge d'ordinateur de gemmes Presidium

Le jauge d'ordinateur de gemmes Presidium a été développé comme une extension du testeur électronique de gemmes Presidium existant avec des fonctions supplémentaires, à savoir :

- Il mesure de manière précise les dimensions des gemmes et vous renseigne sur leur poids et leur identité
- Il peut mesurer 74 gemmes et 9 tailles différentes
- Précision des mesures jusqu'à 0,01 mm
- Conversion directe en carat pour des diamants ronds taille brillant
- Affichage clair et visible pour une lecture facile des mesures
- Instrument de poche léger pouvant être utilisé n'importe où.
- Connectivité PC pour pouvoir importer et imprimer facilement les résultats

Caractéristiques du produit :

Gammes de mesures : 0,00 mm à 25,00 mm ou
0,000 ct à 57,343 ct

Pile recommandée : CR 2450 3V ou équivalent

Autonomie : environ 26 heures d'utilisation continue

Inclus dans votre emballage :

- Jauge d'ordinateur de gemmes Presidium
- Pile CR-2450 3V
- Accessoire pour sertissage en hauteur
- Câble USB
- Manuel de l'utilisateur
- Carte de garantie
- Étui de protection

Éléments du testeur

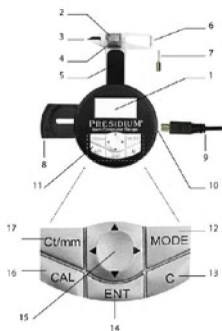

1	Affichage LCD
2	Enclume de la base
3	Pointes en coins
4	Plateau coulissant
5	Plate-forme coulissante
6	Sonde en saillie
7	Accessoire joaillerie
8	Porte-pile
9	Câble USB
10	Port USB
11	Clavier de sélection
12	Touche de mode
13	Touche d'annulation
14	Touche d'entrée
15	Touche de navigation
16	Touche d'activation du calculateur
17	Touche de conversion d'unité

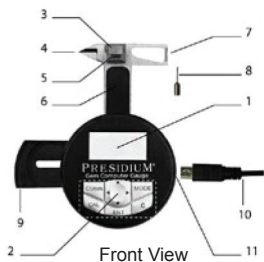

Configuration de l'affichage

L'affichage LCD du PGCG est divisé en trois sections

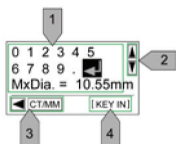

1. Affichage interactif
2. Barre de défilement
3. Barre d'instructions

Configuration du clavier

Veillez vous référer au tableau ci-dessous pour la fonction de chaque touche du clavier.
Certaines touches ont plusieurs fonctions.

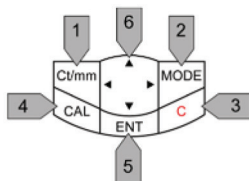

	Touche	Fonction de base	Autres fonctions
1	Ct/mm ↔	Appuyez pour changer l'unité de mesure de millimètre (mm) en carat (Ct)	Dans « Weight Estimator » et « Stone Estimator », appuyez pour basculer entre « Measurement » et « Keypad » pour entrer une dimension.
2	MODE	Appuyez pour afficher la fonction sélection du menu	
3	C	Appuyez pour annuler	<ul style="list-style-type: none"> • Appuyez pour démarrer le PGCG • En mode « Measurement », appuyez pour la fonction tare/zéro
4	CAL	Appuyez pour activer le mode calculateur	Dans « Weight Estimator », appuyez pour calculer le prix
5	ENT	Appuyez pour confirmer le choix	
6	Pavé de navigation	Appuyez pour parcourir les données affichées sur l'écran interactif	

III. AVIS IMPORTANT

- La jauge doit être protégée de l'humidité. Les précipitations et tous les types de liquides ou d'humidité peuvent contenir des minéraux susceptibles de détériorer les circuits électroniques. Si votre testeur est humide, retirez les piles et laissez l'appareil sécher complètement avant de le remettre en place.
- Ne pas utiliser, ranger ou laisser la jauge dans des endroits poussiéreux et sales. Ses pièces et ses composants électroniques peuvent être endommagés.
- Ne pas utiliser, ranger ou exposer la jauge dans des endroits très chauds. Des températures élevées peuvent endommager ou réduire la vie du testeur, endommager les piles et déformer ou faire fondre certains plastiques.
- Ne pas utiliser, ranger ou exposer la jauge dans des endroits froids. Lorsque la jauge reprend sa température normale, de l'humidité risque de se former à l'intérieur du testeur et d'endommager les circuits électroniques.
- Ne tentez pas d'ouvrir la jauge autrement que de la façon indiquée dans ce manuel.
- Vous ne devez ni laisser tomber, ni cogner, ni secouer la jauge. Une manipulation brutale pourrait endommager les circuits internes et les petites pièces mécaniques.
- Ne pas utiliser de produits chimiques décapants, de solvants de nettoyage ou de détergents puissants pour nettoyer la jauge.

- Ne pas peindre la jauge. La peinture peut bloquer les pièces mobiles et empêcher le bon fonctionnement du testeur.

Si votre jauge ne fonctionne pas correctement, veuillez contacter le service clientèle de Presidium service@presidium.com.sg ou :

Presidium Instruments Pte Ltd
Unit 7, 207 Henderson Road
Singapore 159550
Attn: Customer Service Executive

1. PREMIERE UTILISATION de votre jauge Presidium Gem Computer Gauge

Mettre une pile dans votre Presidium Gem Computer Gauge

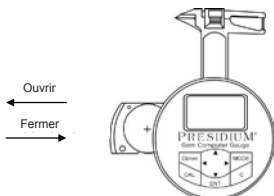

1. Faites glisser le porte-pile situé sur le côté de l'appareil à l'aide d'un petit tournevis ou avec votre ongle.
2. Placez un pile CR 2450 3V avec le signe (+) tourné vers le haut dans le porte-pile et refermez celui-ci en le faisant coulisser vers l'intérieur.
3. Il est préférable d'utiliser une pile alcaline qui assurera environ deux heures et demie de fonctionnement continu, qu'une pile ordinaire offrira une autonomie moins importante.

Mise en marche de votre jauge d'ordinateur de gemmes Presidium

1. Appuyez sur la touche « C » du clavier.
2. Le mot « Presidium » s'affiche et l'instrument se met en mode « Measurement ».
3. L'écran affiche deux lignes, la première montrant les mesures en millimètres et la deuxième les mesures en carats.

Veillez noter que le PGCG s'éteindra automatiquement après 5 minutes d'inactivité.

Informations sur la pile

Ne laissez pas de pile usagée dans le porte-pile car elle pourrait se corroder, fuir ou endommager le testeur. Retirez la pile si vous n'utilisez pas l'appareil pendant une période prolongée.

2. EFFECTUER UN TEST avec votre jauge d'ordinateur de gemmes Presidium

1. Lorsque l'appareil s'allume, il est en mode « Mesures » par défaut.
2. Le PGCG dispose des fonctions suivantes :
 - a) Mesures
 - b) Évaluation du poids
 - c) Dictionnaire des densités
 - d) Évaluation de pierres gemmes
 - e) Calculateur
 - f) Inventaire
 - g). Connectivité avec PC
3. Pour utiliser d'autres fonctions, appuyez sur « MODE » sur le clavier de sélection et choisissez une fonction dans la liste.

a. Mesures

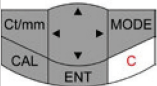
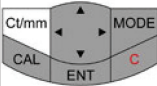
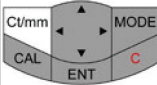
	Éléments requis	Touche d'activation	Affichage
1	<p>Une fois allumé, le PGCG affiche les dimensions en mm et le poids en carats :</p> <p>1. Appuyez sur « C » pour démarrer</p>		0,00 mm 0,000 ct
2	<p>Pour afficher seulement les dimensions en mm</p> <p>1. Appuyez sur « Ct/mm »</p>		0,00 mm
3	<p>Pour afficher seulement le poids en carats :</p> <p>1. Appuyez sur « Ct/mm »</p>		0,000 ct

- La jauge d'ordinateur de gemmes Presidium doit être tenu dans la paume d'une main. Contrôlez la coulisse avec le pouce.

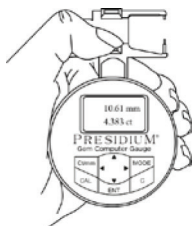

- Lorsque vous mesurez des gemmes non montées, tirez la coulisse (Fig.2.1) et placez la pierre sur la plate-forme de l'enclume coulissante. La base de la gemme doit être parallèle à la plate-forme pour l'empêcher de bouger.

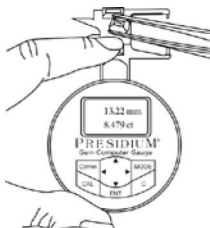

- Quand vous mesurez des gemmes déjà montées, insérez l'accessoire de joaillerie dans le testeur et placez la gemmes entre l'accessoire et la coulisse.



- Fermer doucement la coulisse. Le résultat s'affiche immédiatement.



- Appuyez sur « ct/mm » pour alterner entre les affichages suivants :
 1. Affichage des deux dimensions en mm et du poids en carats (par défaut)
 2. Affichage des dimensions en mm seulement
 3. Affichage du poids en carats seulement

La jauge d'ordinateur de gemmes Presidium (PGCG) est paramétré par défaut pour la taille brillant rond selon la norme américaine

Pour d'autres gemmes de tailles différentes, veuillez passer tout de suite aux indications suivantes.

b. Évaluation du poids



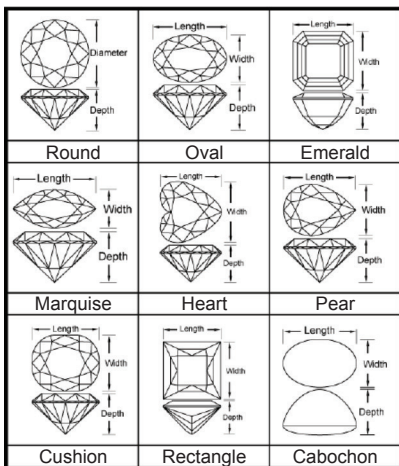

La jauge d'ordinateur de gemmes Presidium (PGCG) évalue le poids de la pierre selon sa forme, son diamètre, sa profondeur et sa nature.

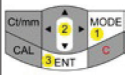
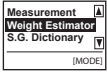

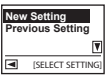
Les diverses tailles des gemmes sont présentées ci-dessous :







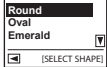
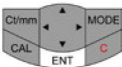

	Actions requises	Touche d'activation	Affichage
1.	<p>Évaluation du poids :</p> <ul style="list-style-type: none"> ⊖ Appuyez sur MODE ⊖ Faites défiler jusqu'à Évaluation ⊗ Appuyez sur « ENT » pour confirmer 		

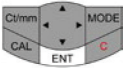
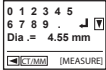
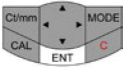
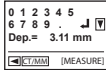

	<p>Choisissez Nouveau réglage ou Réglage précédent</p> <ul style="list-style-type: none"> ⊖ Faites défiler pour choisir ⊖ Appuyez sur « ENT » pour confirmer 		
--	--	---	--

<p style="writing-mode: vertical-rl; transform: rotate(180deg);">3.1 Nouveau réglage</p>	<p>Choisir le nom de la pierre</p> <ul style="list-style-type: none"> ⊖ le nom des pierres Par ordre alphabétique. ⊖ Appuyez sur « ENT » pour confirmer 		
	<p>Choisissez une pierre :</p> <ul style="list-style-type: none"> ⊖ Faites défiler pour choisir ⊖ Appuyez sur « ENT » pour confirmer 		

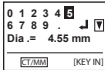
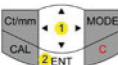
	<p>Choisir une taille :</p> <ul style="list-style-type: none"> ⊖ Faites défiler pour choisir ⊖ Appuyez sur « ENT » pour confirmer <p>Remarque : les diverses dimensions à entrer dépendent de la taille de la pierre. Veuillez consulter la page 79 pour les tailles et dimensions requises.</p>		
<p>3.2 Réglage précédent</p>	<p>Les caractéristiques de la gemme précédente s'affichent :</p> <ul style="list-style-type: none"> • Appuyez sur « ENT » pour confirmer 		

4	<p>Choisir la méthode de mesure :</p> <ul style="list-style-type: none"> ⊖ Faites défiler pour choisir Mesure ou clavier ⊖ Appuyez sur « ENT » pour confirmer 		
4.1 Mesures ²	<p>Mesure du diamètre :</p> <ul style="list-style-type: none"> • Placez le diamètre de la gemme sur l'enclume de la base • Appuyez sur « ENT » pour confirmer 		
	<p>Mesure de la profondeur :</p> <ol style="list-style-type: none"> 1. Placez la profondeur de la gemme sur l'enclume de la base 2. Appuyez sur « ENT » pour confirmer 		

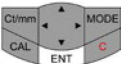
<p>4.2 Clavier</p>	<p>Saisie du diamètre :</p> <ul style="list-style-type: none"> ⊖ Saisie du diamètre de la gemme ⊖ Pour confirmer la saisie, déplacez le curseur sur ← et appuyez sur « ENT » 		
	<p>Saisie de la profondeur :</p> <ul style="list-style-type: none"> ⊖ Saisie de la profondeur de la gemme ⊖ Pour confirmer la saisie, déplacez le curseur sur ← et appuyez sur « ENT » <p>Veillez noter que si vous appuyez sur Ct/mm vous basculerez entre les deux méthodes « Clavier » ou « Mesure »</p>		

<p>5.</p>	<p>Le diamètre et la profondeur de la gemme s'affichent.</p> <ul style="list-style-type: none"> Appuyez sur « ENT » pour confirmer 		<p>Dia . = 4.55 mm Dep. = 3.11 mm</p> <p>[SUMMARY P1]</p>
<p>6.</p>	<p>L'évaluation du poids de la gemme s'affiche. À ce stade, l'utilisateur peut soit appuyer sur « ENT » pour enregistrer soit sur « CAL » pour le calcul du prix. Plus de détails seront donnés aux paragraphes 6.1 et 6.2 ci-dessous</p>		<p>Diamond Round weight = 0.299 ct</p> <p>[CAL] [SUMMARY P2]</p>
	<p>Enregistrement des données dans l'inventaire :</p> <ul style="list-style-type: none"> Appuyez sur « ENT » pour enregistrer les données Faites défiler pour choisir « OUI/NON » 		<p>No Yes</p> <p>[SAVE STONE?]</p>

6.1 Stockage de données

- ⊖ Si vous choisissez « NON », le menu « Choisir le réglage » s'affiche de nouveau pour la mesure suivante.
- ⊖ Vous pouvez alors choisir « Nouveau réglage » pour une nouvelle gemme ou « Réglage précédent » pour la gemme précédente.
- ⊖ Appuyez sur « ENT » pour confirmer

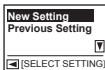

⊖ Si vous choisissez « OUI », les détails de la gemme sont enregistrés dans l' « Inventaire ».

⊖ Appuyez sur « ENT » pour confirmer.

Après avoir enregistré les données, le menu « Choisir le réglage » s'affiche de nouveau, et vous pouvez alors choisir « Nouveau réglage » pour une nouvelle gemme ou « Réglage précédent » pour la gemme précédente.

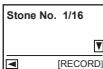

Calcul du prix d'une pierre :

- Appuyez sur « CAL »

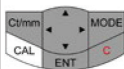

6.2 Calcul du prix

Saisie du prix :

- ⊖ Pour saisir les données, déplacer le curseur sur  pour sélectionner les données et appuyez sur « ENT »
- ⊖ Pour confirmer le prix par carat, déplacez le curseur et appuyez sur « ENT »

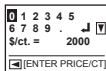

Le prix de la gemme s'affiche.

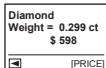

Enregistrement des données dans l'inventaire :

- Appuyez sur « ENT » pour enregistrer les données
- Déplacez le curseur et choisissez « OUI » pour enregistrer.
- Appuyez sur « ENT » pour confirmer
- Après avoir enregistré les données, le menu « Choisir le réglage » s'affiche de nouveau pour les mesures suivantes.

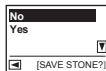
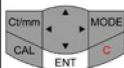

Veillez noter que seuls les réglages de la gemme sont enregistrés. La fonction d'enregistrement est semblable à la section 6.1 ci-dessus. Le prix de la gemme ne sera pas enregistré.



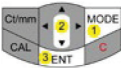
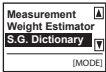

c. Dictionnaire des densités (S.G.)

La jauge d'ordinateur de gemmes Presidium permet de déterminer approximativement la nature d'une gemme en fonction de sa densité. La jauge d'ordinateur de gemmes Presidium comprend un dictionnaire des densités d'un certain nombre de gemmes pour votre référence.

Veillez noter qu'il sera nécessaire d'obtenir le poids de la gemme à partir d'une autre source afin de pouvoir l'identifier formellement.

	Actions requises	Touche d'activation	Affichage
1.	<p>Sélection du dictionnaire des densités :</p> <ul style="list-style-type: none"> ⊖ Appuyez sur MODE ⊖ Faites défiler jusqu'à « S.G. Dictionary » ⊗ Appuyez sur « ENT » pour confirmer 		
2.	<p>Choisir le nom de la gemme</p> <ul style="list-style-type: none"> ⊖ Faites défiler pour sélectionner la première lettre du nom de la gemme. ⊖ Appuyez sur « ENT » pour confirmer 		

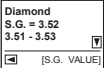

	<p>Choisissez une gemme :</p> <ul style="list-style-type: none"> ⊖ Faites défiler pour choisir ⊖ Appuyez sur « ENT » pour confirmer 		
4.	<p>La densité de la gemme sélectionnée s'affiche.</p>		

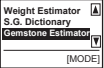

d. Évaluation de gemmes

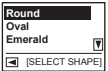

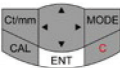
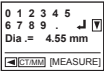
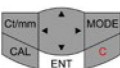
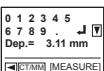

Pour déterminer la densité de la gemme à tester :

	Actions requises	Clef d'activation	Affichage
1.	<p>Sélectionnez Évaluation de gemmes</p> <ul style="list-style-type: none"> ⊖ Appuyez sur MODE ⊖ Faites défiler jusqu'à Évaluation de gemmes ⊗ Appuyez sur « ENT » pour confirmer 		

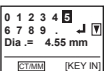
<p>2. Choisissez une taille.</p> <ul style="list-style-type: none"> ⊖ Faites défiler pour choisir ⊖ Appuyez sur « ENT » pour confirmer <p>³ Veuillez vous référer à la page 79 pour les tailles</p> <p>⁴ Les diverses dimensions à entrer dépendent de la taille de la gemme. Veuillez consulter la page 79 pour les tailles et dimensions requises.</p>			
--	--	---	---

<p>3. Sélectionnez la méthode de mesure :</p> <ul style="list-style-type: none"> ⊖ Faire défiler pour choisir Mesure ou Clavier ⊖ Appuyez sur « ENT » pour confirmer 			
--	--	---	---

3.1 Mesures ⁴	<p>Mesure du diamètre :</p> <ul style="list-style-type: none"> Placez le diamètre de la gemme sur l'enclume de la base Appuyez sur « ENT » pour confirmer 		
	<p>Mesure de la profondeur :</p> <ul style="list-style-type: none"> Placez la profondeur de la gemme sur l'enclume de la base Appuyez sur « ENT » pour confirmer 		
3.2 Clavier	<p>Saisie du diamètre :</p> <ul style="list-style-type: none"> ⊖ Entrez le diamètre de la gemme ⊖ Pour confirmer la saisie, déplacer le curseur sur ← et appuyez sur « ENT » 		

<p>3.2 Clavier</p>	<p>Saisie de la profondeur :</p> <ul style="list-style-type: none"> ⊖ Entrez la profondeur de la gemme ⊖ Pour confirmer la saisie, déplacer le curseur sur ← et appuyez sur « ENT » <p>Veillez noter que vous pouvez passer de « Clavier » à « Mesure » à tout moment en appuyant sur Ct/mm</p>		
<p>4</p>	<p>Saisie du poids :</p> <ul style="list-style-type: none"> ⊖ Entrez le poids de la gemme ⊖ Pour confirmer la saisie, déplacer le curseur sur □ et appuyez sur « ENT » 		

5	<p>La densité de la gemme est calculée. La liste des gemmes⁵ avec leur densité respective s'affiche.</p> <p>⁵ Veuillez vous référer à la Page 99-100 pour la liste des gemme dans le PGCG</p>		
---	---	--	--

e. Calculateur

La jauge d'ordinateur de gemmes Presidium (PGCG) vous permet aussi de faire des calculs simples.

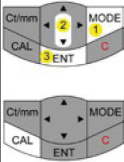
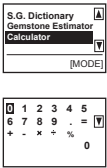

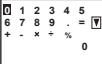

	Actions requises	Touche d'activation	Affichage
1.	<p>Sélectionnez le Calculateur</p> <ul style="list-style-type: none"> ⊖ Appuyez sur MODE ⊖ Faites défiler jusqu'à Calculator. ⊗ Appuyez sur « ENT » pour confirmer <p>Ou, appuyez sur « CAL » pour sélectionner le calculateur</p>		

2.	<p>Calculs :</p> <ul style="list-style-type: none"> • Pour saisir des données, déplacez le curseur sur les chiffres et les symboles et appuyez sur « ENT » 		
----	---	--	--

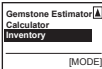
f. Inventaire

La jauge d'ordinateur de gemmes Presidium (PGCG) vous permet de sauvegarder les détails (par exemple, identité, taille et poids) des pierres pour référence future.

	Actions requises	Touche d'activation	Affichage
1.	<p>Sélectionnez Inventaire :</p> <ul style="list-style-type: none"> ⊖ Appuyez sur MODE ⊖ Faites défiler jusqu'à Inventaire ⊗ Appuyez sur « ENT » pour confirmer 		

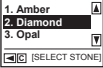
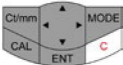
2.	Toutes les gemmes sauvegardées dans la mémoire seront accessibles		
3.	<p>Sélectionnez les détails des gemmes :</p> <ul style="list-style-type: none"> ⊖ Faites défiler pour choisir ⊖ Appuyez sur « ENT » pour confirmer 		
4.	<p>Suppression des détails de la gemme sélectionnée :</p> <ul style="list-style-type: none"> ⊖ Faites défiler jusqu'à l'enregistrement de la gemme que vous voulez supprimer ⊖ Appuyez sur « ENT » pour confirmer 		
	<ul style="list-style-type: none"> • Appuyez sur « C » pour supprimer 		

	<ul style="list-style-type: none"> ⊖ Choisissez « Supprimer » et appuyez sur « ENT » pour confirmer. ⊖ Choisissez « Oui » et appuyez sur « ENT » pour confirmer 		<div style="border: 1px solid black; padding: 5px; margin-bottom: 10px;"> Delete Delete all [DELETE OPTION] </div> <div style="border: 1px solid black; padding: 5px;"> No Yes [DELETE STONE?] </div>
--	---	--	---

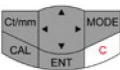
	<p>Suppression des détails de toutes les gemmes en mémoire :</p> <ul style="list-style-type: none"> ⊖ Faites défiler jusqu'à l'enregistrement d'une gemme ⊖ Appuyez sur « ENT » pour confirmer 		<div style="border: 1px solid black; padding: 5px;"> 1. Amber 2. Diamond 3. Opal [STONE DETAIL] </div>
	<ul style="list-style-type: none"> • Appuyez sur « C » pour supprimer 		

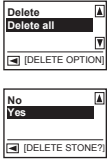
<p>⊖ Choisissez « Tout supprimer » et appuyez sur « ENT » pour confirmer.</p> <p>⊖ Choisissez « Oui » et appuyez sur « ENT » pour confirmer</p>		
---	--	--

g. Connectivité avec PC

La jauge Presidium Gem Computer est livrée avec un logiciel téléchargeable permettant d'accéder à plus de sélection de gemmes. veuillez cliquer sur www.presidium.com.sg

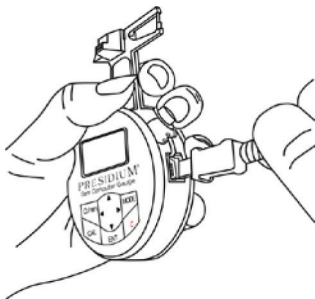

Ce logiciel n'est actuellement pas encore compatible avec les plateformes Mac OS.

3. LIRE LES RÉSULTATS DE TEST sur votre jauge d'ordinateur de gemmes Presidium

Les densités des gemmes suivantes sont stockées dans
votre jauges numérique de gemmes Presidium :

Pierres courantes (par ordre alphabétique)	
Albite	Néphrite
Alexandrite	Obsidienne
Almandin	Oligoclase feldspar
Ambre	Opale
Andalousite	Orthoclase
Andradite grenat	Perle
Apatite	Peridot
Benitoite	Plastique
Béryl	Pyrope grenat
Brazilianite	Quartz
Calcite	Rhodochrosite
Chalcedony	Rhodolite grenat
Corail	Rhodonite
Corundum	Saphir
Cubic zirconium oxide	-
Diamant	Serpentine
Danburite	Coquillage
Diopside	Sinhalite
Dioptase	Sodalite
Fluorite	Sopodumene
Verre	Spessartite grenat
G.G.G.	Sphère
Hématite	Spinelle
Idocrase	Strontium titanate

Iolite	Synthetic emerald
Ivory	Synthetic rutile
Jadeite	Synthetic spinel
Jet	TL grossularite garnet
Kornerupine	Topaz
Kyanite	Tourmaline
Labradorite feldspar	TP grossularite garnet
Lapis lazuli	Turquoise
Moissanite	Verdite
Malachite	Y.A.G
Microcline	Zircon (high)
Moldavite	Zircon (low)
	Zircon (medium)
	Zoisite

4. PRENDRE SOIN de votre jauge d'ordinateur de gemmes Presidium

- Ne laissez pas de piles usagées dans le porte-piles car elles pourraient se corroder, fuir ou endommager la jauge. Retirez la pile si vous n'utilisez pas l'appareil pendant une période prolongée.

Votre testeur est un produit dû à une conception et une technologie avancées et doit être manipulé avec précaution.

Merci d'avoir pris le temps de parcourir le manuel d'utilisation qui vous permettra de mieux comprendre votre récent achat.

Presidium recommande également d'enregistrer votre garantie en nous envoyant la carte de garantie ou en l'enregistrant en ligne ici : <http://www.presidium.com.sg/>

Benutzeranleitung für Presidium Gem Computer Gauge (PGCG)

Inhalt

(German Version)

- I. Über diese Anleitung pg. 104

- II. Informationen zu Ihrem Presidium Gem
Computer Gauge pg. 105

- III. WICHTIGER HINWEIS pg. 109

- 1. ERSTE SCHRITTE mit dem Presidium
Gem Computer Gauge pg. 111

- 2. DURCHFÜHREN EINER MESSUNG
mit dem Presidium Gem Computer
Gauge pg. 112
 - a. Messung
 - b. Gewichtschätzung
 - c. Verzeichnis spezifischer Dichten (S.G.)
 - d. Edelsteinbestimmung
 - e. Rechner
 - f. Inventar
 - g. PC-Anschluss

- 3. DURCHFÜHREN EINER MESSUNG
mit dem Presidium Gem Computer
Gauge pg. 136

- 4. WARTUNG UND PFLEGE des Presidium
Gem Computer Gauge pg. 138

I. Über diese Anleitung

Vielen Dank, dass Sie sich für den Presidium Gem Computer Gauge ("PGCG" oder "Messgerät") entschieden haben.

Diese Anleitung soll Ihnen die Inbetriebnahme des Messgeräts erleichtern und enthält alle erforderlichen Informationen zur korrekten Nutzung des Messgeräts und der sachgerechten Pflege. Bitte lesen Sie diese Anleitung sorgfältig und bewahren Sie sie für einen späteren Gebrauch an einem sicheren Ort auf.

II. Informationen zu Ihrem Presidium Gem Computer Gauge

Der Presidium Gem Computer Gauge wurde als Erweiterung des bestehenden Presidium Electronic Gemstone Gauge entwickelt und bietet zusätzliche Funktionen:

- Misst tatsächliche Edelsteinmaße und schätzt Gewicht und Art von Edelsteinen
- Misst 74 Edelsteinarten und 9 verschiedene Formen
- Präzisionsmessung bis zu 0,01 mm
- Direkte Karatumwandlung für runde Brillantschliff-Diamanten
- Klares, lesbares Display zum komfortablen Ablesen von Messungen
- Leichtes, tragbares Gerät – lässt sich überall einsetzen
- PC-Anschluss für einfaches Importieren und Drucken von Messergebnissen

Produktspezifikationen:

Messbereich: 0,00 mm bis 25,00 mm bzw. 0,000 ct bis 57,343 ct

Empfohlene Batterie: CR 2450 3V oder gleichwertig

Batterie-Lebensdauer: allgemein etwa 26 Stunden kontinuierlicher Betrieb

Inhalt der Verpackung:

- Presidium Gem Computer Gauge
- CR-2450 3V-Batterie
- Schmuckaufsatz für hohe Fassungen
- USB-Kabel
- Benutzeranleitung
- Garantiekarte
- Schutzbehälter

Geräteteile

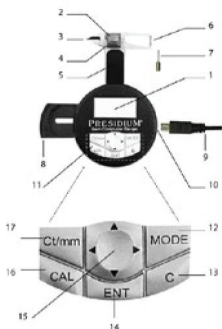

1	LCD-Display
2	Basisanschlag
3	V-förmiger Messschenkel
4	Schieber
5	Schieberplattform
6	Abgesetzte Messzange
7	Schmuckaufsatz
8	Batteriefach
9	USB-Kabel
10	USB-Anschluss
11	Auswahltasten
12	Modustaste
13	Löschtaste
14	Eingabetaste
15	Navigationstaste
16	Berechnungstaste
17	Umwandlungstaste

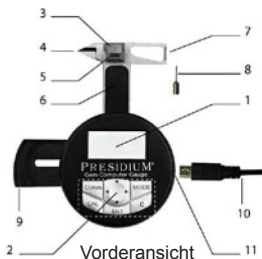

Display-Konfiguration

Die LCD-Anzeige des PGCG ist in drei allgemeine Abschnitte gegliedert.

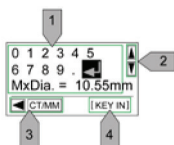

1. Interaktives Display
2. Rollbalken
3. Anweisungsleiste

Tastenkonfiguration

Folgende Tabelle zeigt die Funktion der Auswahltasten. Einige Tasten sind mit mehreren Funktionen belegt.

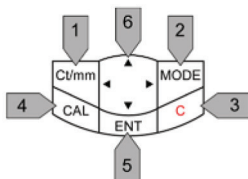

	Name	Normale Funktion	Zusatzfunktion
1	Karat ↔ mm	Umwandlung zwischen Millimeter (mm) und Karat (Ct) durch Drücken der Taste	In den Modi „Gewichtsschätzung“ und „Steinbestimmung“ schaltet die Taste zwischen „Messen“ und „Tastatur“ zur Maßeingabe um
2	Modus	Ruft das Funktionsauswahlmenü auf	
3	Abbrechen	Löschen von Elementen	<ul style="list-style-type: none"> • Einschalten des PGCG • Im „Messmodus“ für Tara/Nullstellung
4	Taschenrechner	Aktiviert den Rechnermodus	Im Modus „Gewichtsschätzung“ zur Preisberechnung drücken
5	Eingabe	Zur Bestätigung einer Auswahl drücken	
6	Navigations-tasten	Zum Navigieren von Daten im interaktiven Display	

III. WICHTIGER HINWEIS

- Das Messgerät trocken halten. Niederschlag und Flüssigkeiten oder Feuchtigkeit können Mineralien enthalten, die auf elektrische Schaltkreise korrodierend wirken. Falls das Messgerät nass wird, entfernen Sie die Batterie und lassen Sie es vor der weiteren Verwendung vollständig trocknen.
- Das Messgerät nicht in staubiger oder verschmutzter Umgebung lagern oder betreiben. Die beweglichen Teile und elektronische Bauelemente könnten beschädigt werden.
- Das Messgerät nicht bei Hitze lagern oder betreiben. Hohe Temperaturen können die Lebensdauer des Messgerätes verkürzen oder das Gerät bzw. dessen Batterien beschädigen – zusätzlich können bestimmte Plastikteile des Gerätes sich verziehen oder schmelzen.
- Das Messgerät nicht bei Kälte lagern oder betreiben. Bei der anschließenden Erwärmung auf die Normaltemperatur kann sich im Inneren des Messgerätes Feuchtigkeit niederschlagen und die elektronischen Bauteile beschädigen.
- Nicht versuchen, das Messgerät auf andere Weise als in der Anleitung beschrieben zu öffnen.
- Messgerät nicht fallen lassen, stoßen oder schütteln. Rauer Umgang kann zu Brüchen interner Schaltkreise und der Feinmechanik führen.
- Keine aggressiven Chemikalien, scharfe Reinigungsmittel oder Lösungsmittel zum Reinigen des Messgerätes verwenden.

- Das Messgerät nicht lackieren oder bemalen. Lack oder Farbe kann die beweglichen Teile verkleben und den einwandfreien Betrieb verhindern.

Falls das Messgerät nicht korrekt funktioniert, wenden Sie sich bitte an den Presidium-Kundendienst unter service@presidium.com.sg oder an:

Presidium Instruments Pte Ltd
Unit 7, 207 Henderson Road
Singapore 159550
Attn: Customer Service Executive

1. ERSTE SCHRITTE mit dem Presidium Gem Computer Gauge

Einlegen der Batterie in den Presidium Gem Computer Gauge

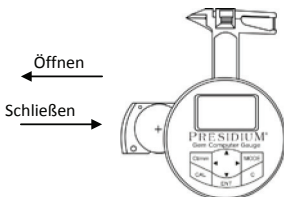

1. Ziehen Sie den Batterieschieber mit dem Finger oder einem Schraubendreher nach außen zur Seite.
2. Setzen Sie eine CR 2450 3 V-Batterie mit dem (+) Symbol nach oben in das Batteriefach ein und drücken Sie den Batterieschieber seitlich nach innen.
3. Der Einsatz von Alkalibatterien wird empfohlen – dadurch ergibt sich im Gegensatz zu herkömmlichen Batterien mit geringerer Kapazität eine kontinuierliche Laufzeit von etwa 2,5 Stunden.

Informationen zu Ihrem Presidium Gem Computer Gauge

1. Drücken Sie die „C“-Taste auf dem Auswahltastenfeld
2. Das Wort „Presidium“ wird angezeigt und das Gerät wird automatisch in den Messmodus versetzt.
3. Auf dem Display werden zwei Zeilen angezeigt; die erste zeigt das Messergebnis in Millimetern und die zweite das Ergebnis in Karat.

Bitte beachten Sie, dass sich der PGCG nach 5 Minuten Nichtbenutzung automatisch abschaltet.

Hinweise zum Batteriebetrieb

Entnehmen Sie verbrauchte Batterien aus dem Batteriefach, da Batterien korrodieren oder auslaufen und das Messgerät beschädigen können. Entnehmen Sie die Batterien auch, wenn das Instrument voraussichtlich für einen längeren Zeitraum nicht verwendet wird.

2. DURCHFÜHREN EINER MESSUNG mit dem Presidium Gem Computer Gauge

1. Standardmäßig befindet sich das Gerät nach dem Einschalten im Messmodus.
2. Der PGCG enthält die folgenden Funktionen:
 - a) Messung
 - b) Gewichtschätzung
 - c) Verzeichnis spezifischer Dichten (S.G.)
 - d) Edelsteinbestimmung
 - e) Taschenrechner
 - f) Inventar
 - g) PC-Anschluss
3. Um andere Funktionen zu nutzen, drücken Sie "Modus" auf dem Auswahltastenfeld und wählen Sie eine Funktion aus der Liste.

a. Messung

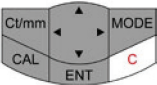
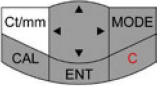
	Funktion	Aktivieren mit Taste	Display
1	<p>Nach dem Einschalten zeigt der PGCG die Maße in mm und das Gewicht in Karat an:</p> <p>1. Drücken Sie zum Einschalten „C“</p>	 <p>Das Diagramm zeigt den Tastensatz des PGCG. Die Taste 'C' ist rot hervorgehoben. Die anderen Tasten sind 'Ct/mm', 'MODE', 'CAL', 'ENT' und ein vierseitiges Navigationskreuz.</p>	0.00 mm 0.000 ct
2	<p>Nur Maße in mm anzeigen:</p> <p>1. „Ct/mm“ drücken</p>	 <p>Das Diagramm zeigt den Tastensatz des PGCG. Die Taste 'Ct/mm' ist hervorgehoben. Die anderen Tasten sind 'MODE', 'CAL', 'ENT' und ein vierseitiges Navigationskreuz.</p>	0.00 mm

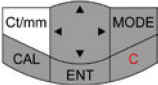
3	<p>Nur Gewicht in Karat anzeigen:</p> <p>1. „Ct/mm“ drücken</p>		0.000 ct
---	---	---	----------

- Der Presidium Gem Computer Gauge sollte in der Handfläche gehalten werden. Bewegen Sie den Schieber mit der Daumenauflage.

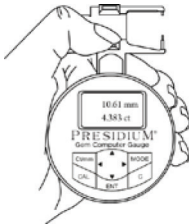

- Ziehen Sie beim Messen loser Steine den Schieber und setzen Sie den Stein auf die Schieberfläche. Achten Sie darauf, dass die Grundfläche des Steins parallel zur Schieberfläche ist, damit er sich nicht bewegt.

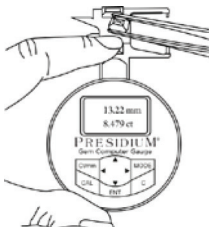

- Setzen Sie beim Messen gefasster Steine den Schmuckaufsatz auf das Messgerät platzieren Sie den Stein zwischen Schmuckaufsatz und Schieberanschlag.



- Schließen Sie langsam den Schieber. Das Messergebnis wird sofort im Anzeigefenster angezeigt.



- Drücken Sie "ct/mm", um zwischen folgenden Anzeigemodi zu wechseln:
 1. Anzeigen von Maßen in mm und Gewicht in Karat (standardmäßig)
 2. Nur Maße in mm anzeigen
 3. Nur Gewicht in Karat anzeigen

Die Standardeinstellung des Presidium Gem Computer Gauge (PGCG) ist für Brilliantrundschliff nach US-Standard programmiert



Gehen Sie für unterschiedlich geformte Edelsteine wie folgt vor.

b. Gewichtschätzung

Der Presidium Gem Computer Gauge (PGCG) schätzt das Gewicht eines Edelsteins anhand von Form, Durchmesser, Tiefe und Art des Steins.

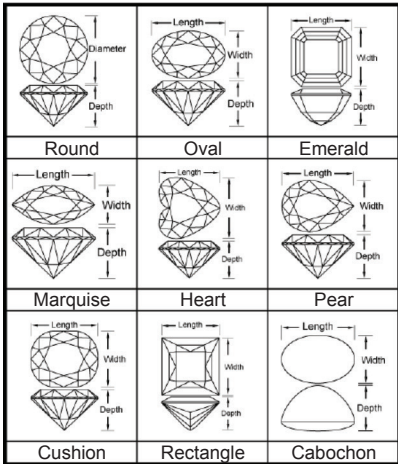
Die verschiedenen Edelsteinformen zeigt das folgende Diagramm:

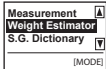

	Funktion	Aktivieren mit Taste	Display
1.	<p>Wählen Sie Ge- wichtsschätzung:</p> <ul style="list-style-type: none"> ⊖ Modus aus- wählen ⊖ Zu „Ge- wichtsschät- zung“ ⊗ Zum Bestä- tigen „ENT“ drücken 		
2.	<p>Wählen Sie Neu oder Bisherige Einstellung:</p> <ul style="list-style-type: none"> ⊖ Zur Auswahl rollen ⊖ Zum Bestätigen „ENT“ drücken 		

3.1 Neue Einstellung

Edelsteinart auswählen:

- ⊖ Zur Auswahl der Edelsteinart nach dem ersten Buchstaben rollen.
- ⊖ Zum Bestätigen „ENT“ drücken



Edelstein auswählen:

- ⊖ Zur Auswahl der Edelsteinart rollen
- ⊖ Zum Bestätigen „ENT“ drücken





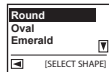

Form auswählen:

- ⊖ Zur Auswahl der Edelsteinart rollen
- ⊖ Zum Bestätigen „ENT“ drücken

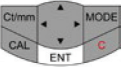

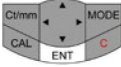
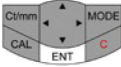

Hinweis: Die jeweils auszuwählenden Maße sind von der Form des Edelsteins abhängig. Seite 116 zeigt die Formen mit den jeweils erforderlichen Eingabemaßen.

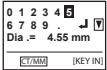

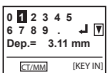
<p>3.2 Bisherige Einstellung</p>	<p>Die Einstellung des bisher gewählten Edelsteins wird angezeigt:</p> <ul style="list-style-type: none"> • Zum Bestätigen „ENT“ drücken 		<div style="border: 1px solid black; padding: 5px;"> <p>Diamond Round</p> <hr/> <p>[PREV. SETTING]</p> </div>
<p>4</p>	<p>Messmethode auswählen:</p> <ul style="list-style-type: none"> ⊖ Zur Auswahl von „Messen“ oder „Tastenfeld“ rollen ⊖ Zum Bestätigen „ENT“ drücken 		<div style="border: 1px solid black; padding: 5px;"> <p>Measurement Keypad</p> <hr/> <p>[SELECT INPUT]</p> </div>
<p>4.1 Messen²</p>	<p>Messen des Durchmessers:</p> <ul style="list-style-type: none"> • Durchmesser des Edelsteins auf die Basis legen • Zum Bestätigen „ENT“ drücken 		<div style="border: 1px solid black; padding: 5px;"> <p>0 1 2 3 4 5 6 7 8 9 . ↓ ▾</p> <p>Dia. = 4.55 mm</p> <hr/> <p>[CT/MM] [MEASURE]</p> </div>
	<p>Messen der Tiefe:</p> <ol style="list-style-type: none"> 1. Tiefe des Edelsteins auf die Basis legen 2. Zum Bestätigen „ENT“ drücken 		<div style="border: 1px solid black; padding: 5px;"> <p>0 1 2 3 4 5 6 7 8 9 . ↓ ▾</p> <p>Dep. = 3.11 mm</p> <hr/> <p>[CT/MM] [MEASURE]</p> </div>

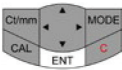
<p>4.2 Tastenfeld</p>	<p>Eingeben des Durchmessers:</p> <ul style="list-style-type: none"> ⊖ Durchmesser des Edelsteins eingeben ⊖ Zum Bestätigen der Eingabe mit dem Cursor zu ↵ gehen und „ENT“ drücken 		
-----------------------	---	---	---

	<p>Eingeben der Tiefe:</p> <ul style="list-style-type: none"> ⊖ Tiefe des Edelsteins eingeben ⊖ Zum Bestätigen der Eingabe mit dem Cursor zu ↵ gehen und „ENT“ drücken <p>Bitte beachten Sie, dass ein Tastendruck auf „Ct/mm“ jeweils zwischen „Tastefeld“ und „Messen“ umschaltet</p>		
--	--	---	---

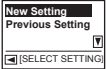
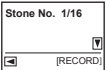
5.	<p>Übersicht über Durchmesser und Tiefe von Edelsteinen</p> <ul style="list-style-type: none"> • Zum Bestätigen „ENT“ drücken 		<div style="border: 1px solid black; padding: 5px;"> <p>Dia . = 4.55 mm Dep. = 3.11 mm</p> <hr/> <p><input type="checkbox"/> [SUMMARY P1]</p> </div>
6.	<p>Das geschätzte Gewicht des Edelsteins wird angezeigt. Der Benutzer kann durch Drücken von „ENT“ speichern oder mit „Cal“ berechnen. Weitere Einzelheiten hierzu siehe 6.1 und 6.2</p>		<div style="border: 1px solid black; padding: 5px;"> <p>Diamond Round weight = 0.299 ct</p> <hr/> <p><input type="checkbox"/> CAL [SUMMARY P2]</p> </div>
6.1 Daten speichern	<p>Speichern von Daten in das Inventar:</p> <ul style="list-style-type: none"> ⊖ Zum Speichern der Daten „ENT“ drücken ⊖ Zur Auswahl der Edelsteinart „Ja/Nein“ 		<div style="border: 1px solid black; padding: 5px;"> <p>No Yes</p> <hr/> <p><input type="checkbox"/> [SAVE STONE?]</p> </div>

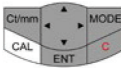
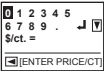
<p>6.1 Daten speichern</p>	<ul style="list-style-type: none"> ⊖ Falls der Benutzer „Nein“ auswählt, zeigt das Display wieder „Einstellung auswählen“ für die nächste Messung an. ⊖ Der Benutzer hat die Möglichkeit zur Auswahl zwischen bisheriger und neuer Steineinstellung. Zum Bestätigen „ENT“ drücken 		
<p>6.1 Daten speichern</p>	<ul style="list-style-type: none"> ⊖ Falls der Benutzer „Ja“ auswählt, werden Details des Edelsteins im „Inventar“ gespeichert. ⊖ Zum Bestätigen „ENT“ drücken <p>Nach dem Speichern der Daten wird auf dem Display „Einstellung auswählen“ für die nächste Messung angezeigt. Benutzer können zwischen bisherigen oder neuen Steineinstellungen auswählen.</p>		

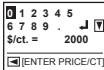
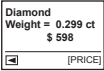
	<p>Preisberechnung von Edelsteinen:</p> <ul style="list-style-type: none"> • „CAL“ drücken 		
<p>6.2 Preisberechnung</p>	<p>Eingeben des Preises:</p> <ul style="list-style-type: none"> ⊖ Zur Dateneingabe mit dem Cursor zu  navigieren, Daten auswählen und „ENT“ drücken ⊖ Preis pro Karat bestätigen, mit de Cursor zu „ENT“ navigieren und drücken. 		
	<p>Der Preis des Edelsteins wird angezeigt</p>		

Speichern von Daten in das Inventar:

- Zum Speichern der Daten „ENT“ drücken
- Rollen, um die Option „Ja“ zum Speichern aufzurufen
- Zum Bestätigen „ENT“ drücken
- Nach dem Speichern der Daten zeigt das Display wieder „Einstellung auswählen“ zur nächsten Messung

Bitte beachten Sie, dass nur die Einstellungen des Steins gespeichert werden. Die Speicherfunktion ist ähnlich wie in Abschnitt 6.1 beschrieben. Der Preis des Edelsteins wird nicht gespeichert.

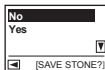
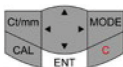



c. Verzeichnis spezifischer Dichten (S.G.)

Der Presidium Gem Computer Gauge ermöglicht das Eingrenzen der Edelsteinart anhand des spezifischen Gewichts (S.G.) Der Presidium Gem Computer Gauge (PGCG) enthält ein Verzeichnis der spezifischen Dichtewerte ausgewählter Edelsteine für Referenzzwecke.

Bitte beachten Sie, dass das Gewicht des Edelsteins als zweite Variable zur Bestimmung des Edelsteins ebenfalls erforderlich ist.

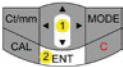
	Funktion	Aktivieren mit Taste	Display
1.	<p>S.G-Verzeichnis auswählen</p> <ul style="list-style-type: none"> ⊖ Modus auswählen ⊖ Zum Eintrag „S.G.-Verzeichnis“ rollen ⊗ Zum Bestätigen „ENT“ drücken 		
2.	<p>Edelsteinart auswählen:</p> <ul style="list-style-type: none"> ⊖ Rollen, um die Edelsteinart nach dem Anfangsbuchstaben auszuwählen ⊖ Zum Bestätigen „ENT“ drücken 		

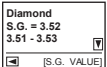
<p>3.</p>	<p>Edelstein auswählen:</p> <ul style="list-style-type: none"> ⊖ Rollen, um die Edelsteinart zu wählen ⊖ Zum Bestätigen „ENT“ drücken 		
<p>4.</p>	<p>Das spezifische Gewicht der ausgewählten Edelsteinart wird angezeigt</p>		

d. Edelsteinbestimmung

So bestimmen Sie das spezifische Gewicht eines Edelsteins:

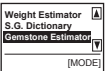
	Funktion	Aktivieren mit Taste	Display
<p>1.</p>	<p>„Edelstein-Analyse“ auswählen:</p> <ul style="list-style-type: none"> ⊖ Modus auswählen ⊖ Zur Option „Edelstein-Analyse“ rollen ⊗ Zum Bestätigen „ENT“ drücken 		

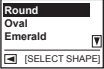
<p>2.</p>	<p>Form auswählen³:</p> <ul style="list-style-type: none"> ⊖ Zum Auswählen rollen ⊖ Zum Bestätigen „ENT“ drücken <p>³ Bitte lesen Sie hierzu Seite 116 mit den Darstellungen der einzelnen Edelsteinformen.</p> <p>⁴ Die jeweils auszuwählenden Maße sind von der Form des Edelsteins abhängig. Seite 116 zeigt die Formen mit den jeweilig erforderlichen Eingabemaßen.</p>		
-----------	---	---	---

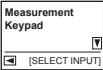
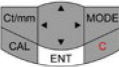
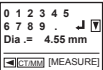
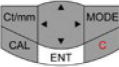
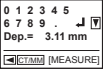
<p>3.</p>	<p>Messmethode auswählen:</p> <ul style="list-style-type: none"> ⊖ Zur Auswahl von „Messen“ oder „Tastentaste“ rollen ⊖ Zum Bestätigen „ENT“ drücken 		
<p>3.1 Messen⁴</p>	<p>Messen des Durchmessers:</p> <ul style="list-style-type: none"> • Durchmesser des Edelsteins auf die Basis legen • Zum Bestätigen „ENT“ drücken 		
	<p>Messen der Tiefe:</p> <ul style="list-style-type: none"> • Tiefe des Edelsteins auf die Basis legen • Zum Bestätigen „ENT“ drücken 		

Eingeben des Durchmessers:

- ⊖ Geben Sie den
- ⊖ Durchmesser des Edelsteins eingeben

Zum Bestätigen der Eingabe mit dem Cursor zu  navigieren und „ENT“ drücken

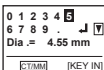



Eingeben der Tiefe:

- ⊖ Tiefe des Edelsteins eingeben
- ⊖ Zum Bestätigen der Eingabe mit dem Cursor zu  navigieren und „ENT“ drücken

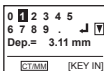

Bitte beachten Sie, dass ein Tastendruck auf „Ct/mm“ jeweils zwischen „Tastensfeld“ und „Messen“ umschaltet



<p>4</p>	<p>Eingeben der Gewichts:</p> <ul style="list-style-type: none"> ⊖ Gewicht eingeben ⊖ Zum Bestätigen der Eingabe mit dem Cursor zu ← navigieren und „ENT“ drücken 		
<p>5</p>	<p>Das spezifische des Edelsteins wird berechnet Eine Liste der Edelsteine⁵ mit den zugehörigen S.G.-Werten wird angezeigt</p> <p>⁵Bitte lesen Sie Seite 136-137 mit der im PGCG enthaltenen Liste der Edelsteine</p>		

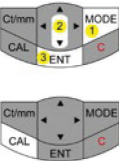
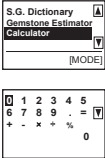

e. Rechner

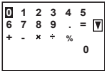

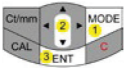
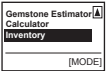
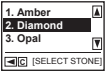

Mit dem Presidium Gem Computer Gauge (PGCG) können Sie auch einfache Berechnungen durchführen.

	Funktion	Aktivieren mit Taste	Display
1.	<p>Rechner auswählen:</p> <ul style="list-style-type: none"> ⊖ Modus auswählen ⊖ Zur Option „Rechner“ rollen ⊗ Zum Bestätigen „ENT“ drücken <p>Als Alternative können Sie den Rechner mit „CAL“ auswählen</p>		
2.	<p>Rechenfunktion:</p> <ul style="list-style-type: none"> • Zur Dateneingabe mit dem Cursor zu den gewünschten Daten navigieren und „ENT“ drücken 		

f. Inventar

Mit dem Presidium Gem Computer Gauge (PGCG) können Sie Details (z. B. Art, Form und Gewicht) des Edelsteins als Referenz speichern.

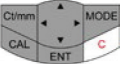
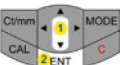
	Funktion	Aktivieren mit Taste	Display
1.	<p>Inventar auswählen:</p> <ul style="list-style-type: none"> ⊖ Modus auswählen ⊖ Zur Option „Inventar“ rollen ⊗ Zum Bestätigen „ENT“ drücken 		
2.	<p>Alle gespeicherten Edelsteine werden aufgelistet</p>		
3.	<p>Edelsteindaten auswählen:</p> <ul style="list-style-type: none"> ⊖ Zum Auswählen rollen ⊖ Zum Bestätigen „ENT“ drücken 		

<p>4</p> <p>Löschen aller ausgewählter Edelsteindaten:</p> <p>⊖ Zum zu löschenden Edelsteindatensatz rollen</p> <p>⊖ Zum Bestätigen „ENT“ drücken</p>		
<ul style="list-style-type: none"> • Zum Löschen „C“ drücken 		
<p>⊖ Aus den Löschoptionen „Alle löschen“ auswählen und zum Bestätigen „ENT“ drücken</p> <p>⊖ „Ja“ auswählen und zum Bestätigen „ENT“ drücken</p>		 

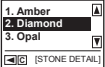
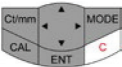
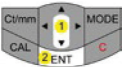
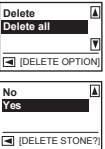
<p>Löschen aller ausgewählter Edelsteindaten:</p> <ul style="list-style-type: none"> ⊖ Zu einem beliebigen Edelsteindatensatz rollen ⊖ Zum Bestätigen „ENT“ drücken 		
<ul style="list-style-type: none"> • Zum Löschen „C“ drücken 		
<ul style="list-style-type: none"> ⊖ Aus den Löschoptionen „Alle löschen“ auswählen und zum Bestätigen „ENT“ drücken ⊖ „Ja“ auswählen und zum Bestätigen „ENT“ drücken 		

g. PC-Anschluss

Das Presidium Gem Computer Gauge wird mit einer herunterladbaren Software geliefert, die Zugriff auf mehr Edelsteine bietet. Bitte klicken Sie auf www.presidium.com.sg

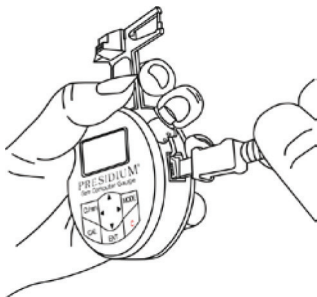

Diese Software ist zur Zeit noch nicht mit Mac OS Plattformen kompatibel.

3. DURCHFÜHREN EINER MESSUNG mit dem Presidium Gem Computer Gauge

Die S.G.-Werte folgender Edelsteine sind im Presidium Gem Computer Gauge gespeichert:

Häufige Steine (in alphabetischer Reihenfolge)	
Albite Feldspat	Nephrit
Alexandrit	Obsidian
Almandit Garnit	Oligoklas Feldspat
Bernstein	Opal
Andalusit	Orthoklas
Andradit Garnit	Perlmutter
Apatit	Peridot
Benitoit	Plastik
Beryl	Pyrope Garnit
Brasilianit	Quartz
Calcit	Rhodochrosit
Chalcedon	Rhodolit Garnit
Koralle	Rhodonit
Korund	Saphir
Kubisches Zirkonoxid	Scapolit
Diamant	Serpentin
Danburit	Muschel
Diopsid	Sinhalit
Dioptase	Sodalit
Fluorit	Sopodumen
Glas	Spessartit Garnit
G.G.G.	Sphene
Hämatit	Spinel

Idokras	Strontium-Titanat
Lolit	Synthetischer Smaragd
Elfenbein	Synthetischer Rutil
Jadeit	Synthetischer Spinel
Gagat	TL Grossularit Garnit
Kornerupin	Topas
Kyanit	Turmalin
Labradorit Feldspat	TP Grossularit Garnit
Lapis-Lazuli	Türkis
Malachit	Verdit
Mikroklin	Y.A.G
Moldavit	Zirkon (hoch)
	Zirkon (niedrig)
	Zirkon (mittel)
	Zoisit

4. WARTUNG UND PFLEGE des Presidium Gem Computer Gauge

- Entnehmen Sie verbrauchte Batterien aus dem Batteriefach, da Batterien korrodieren oder auslaufen und das Messgerät beschädigen können. Entnehmen Sie die Batterien auch, wenn das Instrument voraussichtlich für einen längeren Zeitraum nicht verwendet wird.

Das Messgerät ist ein Präzisionsprodukt und sollte sorgfältig behandelt werden.

Vielen Dank für das Durchlesen dieser Benutzeranleitung, anhand derer Sie das erworbene Produkt besser kennengelernt haben.

Presidium empfiehlt Ihnen, Ihre Gewährleistung auf das Produkt durch Einsenden der Garantiekarte an uns zu registrieren, oder sich online unter <http://www.presidium.com.sg/> zu registrieren.

Guida per l'utente di Presidium Gem Computer Gauge (PGCG)

Indice

(Italian Version)

I. Informazioni su questa guida	pg. 141
II. Informazioni su Presidium Gem Computer Gauge	pg. 142
III. AVVISO IMPORTANTE	pg. 147
1. OPERAZIONI PRELIMINARI con Presidium Gem Computer Gauge	pg. 149
2. SVOLGIMENTO DI UN TEST con Presidium Gem Computer Gauge	pg. 151
a. Misurazione	
b. Funzione di stima del peso	
c. Dizionario di gravità specifica (S.G.)	
d. Funzione di stima delle gemme	
e. Calcolatrice	
f. Inventario	
g. Connettività PC	
3. LETTURA DEI RISULTATI DI UN TEST su Presidium Gem Computer Gauge	pg. 173
4. MANUTENZIONE di Presidium Gem Computer Gauge	pg. 175

I. Informazioni su questa guida

Grazie per aver acquistato Presidium Gem Computer Gauge (“PGCG” o “misuratore”).

Questa guida è stata creata allo scopo di aiutare l'utente a impostare il misuratore e contiene tutte le informazioni necessarie a garantire un utilizzo accurato e una manutenzione in linea con i requisiti del misuratore. Leggere attentamente queste istruzioni e tenerle a portata di mano per futuro riferimento

II. Informazioni su Presidium Gem Computer Gauge

Presidium Gem Computer Gauge è stato creato per essere utilizzato in congiunzione con l'unità Presidium Electronic Gemstone Gauge esistente al fine di fornire funzioni aggiuntive che consentono di svolgere un maggior numero di operazioni, come:

- Misurazione delle dimensioni effettive delle gemme e stima del peso e dell'identità delle gemme
- Misurazioni di 74 gemme e 9 tagli diversi
- Misurazione accurata fino a 0,01 mm
- Conversione diretta in carati per diamanti con taglio a brillante
- Display chiaro e visibile per facilitare la lettura delle misurazioni
- Strumento leggero e portatile utilizzabile ovunque
- Connettività PC per facilitare l'importazione e la stampa dei risultati delle misurazioni

Specifiche del prodotto:

Intervallo di misurazione: da 0,00 mm a 25,00 mm o da 0,000 ct a 57,343 ct

Batteria consigliata: CR 2450 3V o equivalente

Durata della batteria: solitamente circa 26 ore di utilizzo continuativo

Inclusi nella confezione:

- Presidium Gem Computer Gauge
- Batteria CR-2450 3V
- Accessorio per gioielleria con incastonatura alta
- Cavo USB
- Guida dell'utente
- Certificato di garanzia
- Custodia protettiva

Componenti del misuratore

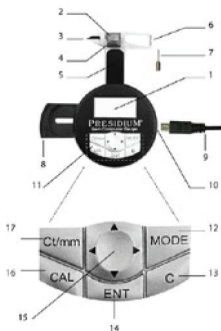

1	Display LCD
2	Incudine della base
3	Punte a cuneo
4	Meccanismo di scorrimento
5	Piattaforma del meccanismo di scorrimento
6	Sonda sporgente
7	Accessorio per gioielleria
8	Vano batterie
9	Cavo USB
10	Porta USB
11	Tastierino di selezione
12	Pulsante Mode
13	Pulsante Clear
14	Pulsante Enter
15	Pulsante Navigation
16	Pulsante Calculator Activation
17	Pulsante Unit Conversion

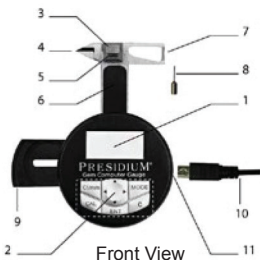

Configurazione del display

Il display LCD di PGCG solitamente è suddiviso in tre sezioni.

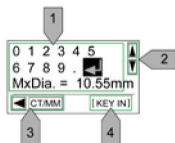

1. Display interattivo
2. Barra di scorrimento
3. Barra di istruzioni

Configurazione del tastierino

Fare riferimento alla tabella sottostante per informazioni sulla funzione di ciascun tasto del tastierino di selezione. Alcuni tasti avranno più di una funzione.

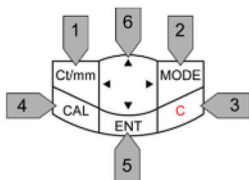

	Nome	Funzione ordinaria	Funzione aggiuntiva
1	Carat ↔ mm	Premere per eseguire la conversione dell'unità di misura tra millimetri (mm) e carati (Ct)	In modalità "Weight Estimator" e "Stone Estimator" mode, premere per alternare "Measurement" e "Keypad" per immettere le dimensioni
2	Mode	Premere per visualizzare il menu di selezione delle funzioni	
3	Cancel	Premere per eliminare gli articoli	<ul style="list-style-type: none"> • Premere per accendere PGCG • In modalità "Measurement", premere per utilizzare la funzione tara/zero
4	Calculator	Premere per attivare la modalità calcolatrice	In modalità "Weight Estimator", premere per calcolare il prezzo

5	Enter	Premere per confermare la selezione	
6	Tastierino di navigazione	Premere per navigare tra i dati nel display interattivo	

III. AVVISO IMPORTANTE

- Tenere all'asciutto il misuratore. La pioggia e tutti i tipi di liquidi o condensa possono contenere minerali in grado di corrodere i circuiti elettrici. In caso di penetrazione di liquidi all'interno del misuratore, rimuovere la batteria e lasciare asciugare completamente il misuratore prima di reinserirla.
- Non utilizzare, conservare o esporre il misuratore ad/in aree ricche di polvere e detriti. Le parti e i componenti elettronici potrebbero restare danneggiati.
- Non utilizzare, conservare o esporre il misuratore ad/in aree con temperature elevate. Le temperature elevate possono danneggiare il tester o accorciarne la durata, danneggiare le batterie e deformare o fondere determinati tipi di plastica.
- Non utilizzare, conservare o esporre il misuratore ad/in aree con temperature ridotte. Quando la temperatura del tester ritorna alla normalità, è possibile che al suo interno si verifichi la formazione di condensa, danneggiando i circuiti elettronici.
- Non tentare di aprire il misuratore seguendo una procedura diversa da quella illustrata all'interno di questa guida.
- Evitare di far cadere, sottoporre a urti o scuotere il misuratore. Il maneggiamento incauto potrebbe provocare la rottura dei circuiti interni e dei meccanismi di precisione.
- Non utilizzare prodotti chimici corrosivi, solventi detergenti o detergenti aggressivi per pulire il misuratore.

- Non verniciare il misuratore. La vernice potrebbe ostruire le parti e impedire il corretto funzionamento. In caso di malfunzionamento del misuratore, contattare il servizio clienti Presidium all'indirizzo di posta elettronica service@presidium.com.sg o tramite corrispondenza all'indirizzo:

Presidium Instruments Pte Ltd
Unit 7, 207 Henderson Road
Singapore 159550
Attn: Customer Service Executive

1. OPERAZIONI PRELIMINARI con Presidium Gem Computer Gauge

Inserimento di una batteria all'interno di Presidium Gem Computer Gauge

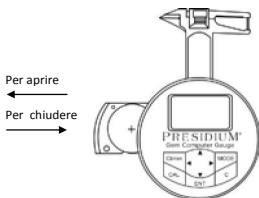

1. Tirare il vano scorrevole della batteria lateralmente verso l'esterno usando le unghie o un cacciavite.
2. Inserire una batteria CR 2450 3V con il simbolo (+) rivolto verso l'alto nel vano della batteria e chiudere spingendo il vano scorrevole della batteria lateralmente verso l'interno.
3. È consigliabile utilizzare batterie alcaline, dal momento che le batterie di questo tipo forniscono solitamente due ore e mezza di autonomia continua, mentre le batterie normali offrono un'autonomia più ridotta.

Accensione di Presidium Gem Computer Gauge

1. Premere il pulsante "C" sul tastierino di selezione.
2. La parola "Presidium" verrà visualizzata sul display e il dispositivo passerà automaticamente alla modalità "Measurement".
3. Lo schermo visualizzerà due righe; la prima rappresenta la misurazione in unità millimetriche e la seconda rappresenta la misurazione in carati.

Notare che PGCG si spegnerà automaticamente dopo 5 minuti di inattività.

Informazioni sulla batteria

Non lasciare le batterie esaurite nel vano delle batterie dal momento che potrebbero corrodersi o danneggiare il misuratore. Rimuovere le batterie quando si prevede di riporre lo strumento per un periodo di tempo prolungato.

2. SVOLGIMENTO DI UN TEST con Presidium Gem Computer Gauge

1. Per impostazione predefinita, all'accensione il dispositivo si troverà in modalità "Measurement".
2. PGCG è dotato delle seguenti funzioni:
 - a) Misurazione
 - b) Funzione di stima del peso
 - c) Dizionario di gravità specifica (S.G.)
 - d) Funzione di stima delle gemme
 - e) Calcolatrice
 - f) Inventario
 - g) Connettività PC
3. Per utilizzare le altre funzioni, premere "Mode" sul tastierino di selezione e scegliere una funzione dall'elenco.

a. Misurazione

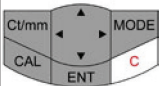
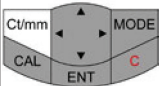
	Requisito	Codice di attivazione	Display
1	<p>All'accensione, PGCG visualizzerà la dimensione in mm e il peso in carati:</p> <p>1. Premere "C" per accendere l'unità</p>		<p>0.00 mm 0.000 ct</p>
2	<p>Per visualizzare le dimensioni esclusivamente in mm:</p> <p>1. Premere "Ct/mm"</p>		<p>0.00 mm</p>

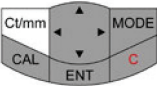
3	<p>Per visualizzare il peso esclusivamente in carati:</p> <p>1. Premere “Ct/mm”</p>		0.000 ct
---	---	---	----------

- Presidium Gem Computer Gauge deve essere impugnato nel palmo della mano destra o sinistra. Controllare il meccanismo di scorrimento con il pollice.



- Per misurare pietre sciolte, tirare il meccanismo di scorrimento e collocare la pietra sulla piattaforma del meccanismo di scorrimento. La base della pietra deve essere parallela alla piattaforma per impedire lo spostamento della pietra.

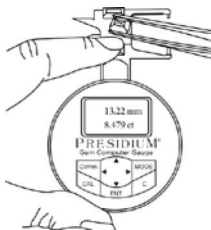

- Per misurare pietre incastonate, inserire l'accessorio per gioielleria nel misuratore e collocare la pietra tra l'accessorio per gioielleria e l'incudine del meccanismo di scorrimento.



- Chiudere lentamente il meccanismo di scorrimento. La lettura verrà visualizzata immediatamente nella finestra.



- Premere "ct/mm" per alternare le seguenti visualizzazioni:
 1. Dimensioni in mm e peso in carati (impostazione predefinita)
 2. Dimensioni esclusivamente in mm
 3. Peso esclusivamente in carati

L'impostazione predefinita di Presidium Gem Computer Gauge (PGCG) è programmata per il taglio a brillante standard americano

Per altre gemme con tagli diversi, procedere direttamente ai passaggi successivi.





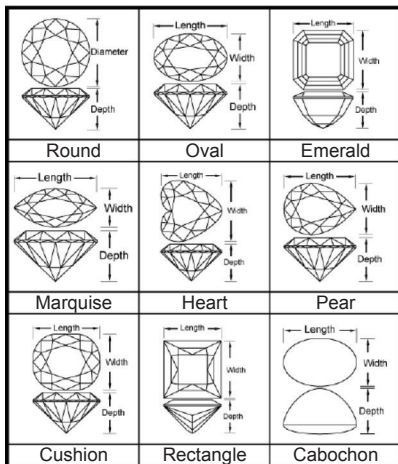

b. Funzione di stima del peso



Presidium Gem Computer Gauge (PGCG) stima il peso della gemma in base alla forma, al diametro, allo spessore e alla natura della gemma.

I vari tagli delle gemme sono illustrati nel seguente diagramma:





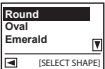
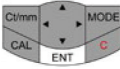



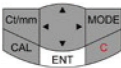
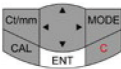

	Requisito	Codice di attivazione	Display
1.	<p>Selezionare Weight Estimator:</p> <ul style="list-style-type: none"> ⊖ Selezionare Mode ⊖ Scorrere fino a Weight Estimator ⊗ Premere "ENT" per confermare 		

2.	<p>Selezionare New o Previous Setting:</p> <ul style="list-style-type: none"> ⊖ Scorrere fino all'opzione desiderata ⊖ Premere "ENT" per confermare 		
3.1 Nuova impostazione	<p>Selezionare il nome della gemma:</p> <ul style="list-style-type: none"> ⊖ Scorrere per selezionare il nome della gemma in base alle iniziali. ⊖ Premere "ENT" per confermare 		
	<p>Selezionare una gemma:</p> <ul style="list-style-type: none"> ⊖ Scorrere fino all'opzione desiderata ⊖ Premere "ENT" per confermare 		

	<p>Selezionare un taglio:</p> <ul style="list-style-type: none"> ⊖ Scorrere fino all'opzione desiderata ⊖ Premere "ENT" per confermare <p>Nota: le varie dimensioni da inserire dipendono dal taglio della gemma. Fare riferimento alla pagina 154 per informazioni sui tagli e sulle rispettive dimensioni richieste.</p>		
<p>3.2 Impostazione precedente</p>	<p>Verrà visualizzata l'impostazione della gemma precedente:</p> <ul style="list-style-type: none"> • Premere "ENT" per confermare 		

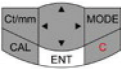
4	<p>Selezionare il metodo di misurazione:</p> <ul style="list-style-type: none"> ⊖ Scorrere tra le opzioni per selezionare misurazione o tastierino ⊖ Premere "ENT" per confermare 		<div style="border: 1px solid black; padding: 5px;"> <p>Measurement Keypad</p> <p style="text-align: right;">▼</p> <p>◀ [SELECT INPUT]</p> </div>
4.1 Misurazione ²	<p>Misurazione del diametro:</p> <ul style="list-style-type: none"> • Posizionare il diametro della gemma sull'incudine della base • Premere "ENT" per confermare 		<div style="border: 1px solid black; padding: 5px;"> <p>0 1 2 3 4 5 6 7 8 9 . ▾ ▼</p> <p>Dia.= 4.55 mm</p> <p>◀ [CT/MM] [MEASURE]</p> </div>
	<p>Misurazione dello spessore:</p> <ol style="list-style-type: none"> 1. Posizionare lo spessore della gemma sull'incudine della base 2. Premere "ENT" per confermare 		<div style="border: 1px solid black; padding: 5px;"> <p>0 1 2 3 4 5 6 7 8 9 . ▾ ▼</p> <p>Dep.= 3.11 mm</p> <p>◀ [CT/MM] [MEASURE]</p> </div>

<p>4.2 Tastierino</p>	<p>Inserimento del diametro:</p> <ul style="list-style-type: none"> ⊖ Inserire il diametro della gemma ⊖ Per confermare l'immissione, portare il cursore su ← e premere "ENT" 		
	<p>Inserimento dello spessore:</p> <ul style="list-style-type: none"> ⊖ Inserire lo spessore della gemma ⊖ Per confermare l'immissione, portare il cursore su ← e premere "ENT" <p>Tenere presente che, in qualsiasi momento, è possibile passare dal metodo di inserimento "Keypad" al metodo "Measurement" e viceversa premendo Ct/mm</p>		

5.	<p>Riepilogo del diametro e dello spessore della gemma.</p> <ul style="list-style-type: none"> • Premere “ENT” per confermare 		<div style="border: 1px solid black; padding: 5px;"> <p>Dia . = 4.55 mm Dep. = 3.11 mm</p> <hr/> <p> [SUMMARY P1]</p> </div>
6.	<p>Verrà visualizzato il peso stimato della gemma. A questo punto, l'utente può premere “Ent” per salvare il valore o “Cal” per calcolare il prezzo. Maggiori dettagli verranno forniti nelle sezioni 6.1 e 6.2 successive</p>		<div style="border: 1px solid black; padding: 5px;"> <p>Diamond Round weight = 0.299 ct</p> <hr/> <p> [CAL] [SUMMARY P2]</p> </div>
6.1 Salvataggio dei dati	<p>Archiviazione dei dati in inventario:</p> <ul style="list-style-type: none"> ⊖ Premere “ENT” per archiviare i dati ⊖ Scorrere per selezionare “YES/NO” 		<div style="border: 1px solid black; padding: 5px;"> <p>No <input type="checkbox"/></p> <p>Yes <input type="checkbox"/></p> <hr/> <p> [SAVE STONE?]</p> </div>

6.1 Salvataggio dei dati



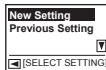
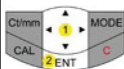

- ⊖ Se l'utente seleziona "NO", il display tornerà a visualizzare "Select Setting" per la misurazione successiva. L'utente potrà scegliere tra l'impostazione precedente o una nuova impostazione per la pietra.
- ⊖ Premere "ENT" per confermare

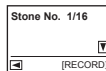

- ⊖ Se l'utente seleziona "YES", i dettagli della gemma vengono salvati in "Inventario"
- ⊖ Premere "ENT" per confermare

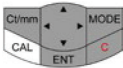
Dopo aver salvato i dati, il display tornerà a visualizzare l'opzione "Seleziona impostazioni" per la misurazione successiva. L'utente potrà scegliere tra le impostazioni precedenti o le nuove impostazioni per la pietra.

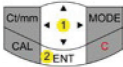

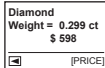
6.2 Calcolo del prezzo	<p>Calcolo del prezzo della gemma:</p> <ul style="list-style-type: none"> • Premere "CAL" 		
	<p>Inserimento del prezzo:</p> <ul style="list-style-type: none"> ⊖ Per inserire i dati, portare il cursore sui ← dati selezionati e premere "ENT" ⊖ Per confermare il prezzo al carato, portare il cursore sulla rispettiva opzione e premere "ENT" 		
	<p>Verrà visualizzato il prezzo della gemma</p>		

Archiviazione dei dati in inventario:

- Premere "ENT" per salvare i dati
- Scorrere fino all'opzione "YES" per la richiesta di salvataggio
- Premere "ENT" per confermare
- Dopo aver salvato i dati, il display tornerà a visualizzare l'opzione "Seleziona impostazione" per la misurazione successiva

Notare che vengono salvate soltanto le impostazioni della pietra. La funzione di salvataggio è simile alla funzione descritta nella sezione 6.1 precedente. Il prezzo della gemma non verrà salvato.

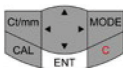



c. Dizionario di gravità specifica (S.G.)

Presidium Gem Computer Gauge consente di classificare le gemme in base al valore S.G.

Presidium Gem Computer Gauge (PGCG) comprende una dizionario dei valori S.G. di alcune gemme selezionate per riferimento.

Notare che sarà necessario inserire il peso della gemma da un'altra origine per consentire l'identificazione della gemma.



	Requisito	Codice di attivazione	Display
1.	<p>Selezionare S.G. Dictionary:</p> <ul style="list-style-type: none"> ⊖ Selezionare Mode ⊖ Scorrere fino a S.G. Dictionary ⊗ Premere "ENT" per confermare 		
2.	<p>Selezionare il nome della gemma:</p> <ul style="list-style-type: none"> ⊖ Scorrere per selezionare il nome della gemma in base all'iniziale ⊖ Premere "ENT" per confermare 		



<p>3.</p>	<p>Selezionare una gemma:</p> <ul style="list-style-type: none"> ⊖ Scorrere fino all'opzione desiderata ⊖ Premere "ENT" per confermare 		
<p>4.</p>	<p>Verrà visualizzato il valore S.G. della gemma selezionata</p>		

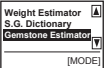

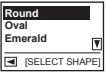

d. Funzione di stima delle gemme

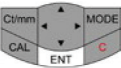
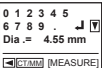
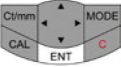
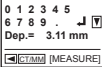
Per determinare l'S.G. della gemma da testare:

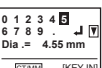
	Requisito	Codice di attivazione	Display
<p>1.</p>	<p>Selezionare Gemstone Estimator:</p> <ul style="list-style-type: none"> ⊖ Selezionare Mode ⊖ Scorrere fino a Gemstone Estimator ⊗ Premere "ENT" per confermare 		

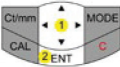
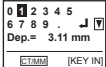
<p>2.</p>	<p>Selezionare un taglio³:</p> <ul style="list-style-type: none"> ⊖ Scorrere fino all'opzione desiderata ⊖ Premere "ENT" per confermare <p>³Fare riferimento a pagina 154 per vedere le immagini dei tagli.</p> <p>⁴ Le varie dimensioni da inserire dipendono dal taglio della gemma. Fare riferimento a pagina 154 per informazioni sui vari tagli e sulle rispettive dimensioni richieste.</p>		
<p>3.</p>	<p>Selezionare il metodo di misurazione:</p> <ul style="list-style-type: none"> ⊖ Scorrere per selezionare measurement o keypad ⊖ Premere "ENT" per confermare 		

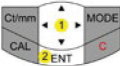
3.1 Misurazione	<p>Misurazione del diametro:</p> <ul style="list-style-type: none"> • Posizionare il diametro della gemma sull'incudine della base • Premere "ENT" per confermare 		
	<p>Misurazione dello spessore:</p> <ul style="list-style-type: none"> • Posizionare lo spessore della gemma sull'incudine della base • Premere "ENT" per confermare 		
3.2 Tastierino	<p>Inserimento del diametro:</p> <ul style="list-style-type: none"> ⊖ Inserire il diametro della gemma ⊖ Per confermare l'immissione, portare il cursore su ← e premere "ENT" 		

<p>3.2 Tastierino</p>	<p>Inserimento dello spessore:</p> <ul style="list-style-type: none"> ⊖ Inserire lo spessore della gemma ⊖ Per confermare l'immissione, portare il cursore su  e premere "ENT" <p>Notare che, in qualunque momento, è possibile passare dal metodo di immissione "Keypad" al metodo "Measurement" e viceversa premendo Ct/mm</p>		
<p>4</p>	<p>Inserimento del peso:</p> <ul style="list-style-type: none"> ⊖ Inserire il peso della gemma ⊖ Per confermare l'immissione, portare il cursore su  e premere "ENT" 		

5	<p>L'unità calcolerà il valore S.G. della gemma. Verrà visualizzato un elenco delle gemme⁵ con il valore SG associato</p> <p>⁵Fare riferimento a pagina 173-174 per l'elenco delle gemme in dotazione con l'unità PGCG</p>		
---	--	--	--

e. Calcolatrice

Presidium Gem Computer Gauge (PGCG) consente inoltre di svolgere semplici calcoli.

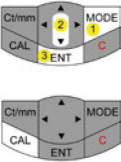
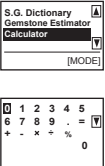

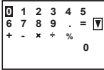
	Requisito	Codice di attivazione	Display
1.	<p>Selezionare Calculator:</p> <ul style="list-style-type: none"> ⊖ Selezionare Mode ⊖ Scorrere fino all'opzione Calculator ⊗ Premere "ENT" per confermare In alternativa, premere "CAL" per selezionare Calculator 		

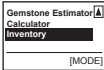
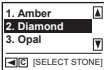

2.	Calcolo: <ul style="list-style-type: none"> Per immettere i dati, portare il cursore sui dati selezionati e premere "ENT" 		
----	---	--	--

f. Inventario

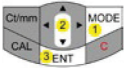
Presidium Gem Computer Gauge (PGCG) consente di salvare i dettagli (ad es., identificazione della gemma, taglio e peso) delle gemme per riferimento.

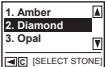
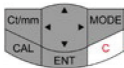
	Requisito	Codice di attivazione	Display
1.	Selezionare Inventory <ul style="list-style-type: none"> ⊖ Selezionare Mode ⊖ Scorrere fino all'opzione Inventory ⊗ Premere "ENT" per confermare 		
2.	Verranno elencate tutte le gemme salvate in memoria		

<p>3.</p>	<p>Selezionare i dettagli della gemma:</p> <ul style="list-style-type: none"> ⊖ Scorrere fino all'opzione desiderata ⊖ Premere "ENT" per confermare 		
<p>4.</p>	<p>Eliminazione dei dettagli della gemma selezionata</p> <ul style="list-style-type: none"> ⊖ Scorrere fino al record della gemma selezionata da eliminare ⊖ Premere "ENT" per confermare 		
	<ul style="list-style-type: none"> • Premere "C" per eliminare 		

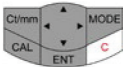
<ul style="list-style-type: none"> ⊖ Selezionare “Delete” tra le opzioni di eliminazione e premere “ENT” per confermare ⊖ Selezionare “Yes” e premere “ENT” per confermare 		<div style="border: 1px solid black; padding: 5px; margin-bottom: 10px;"> Delete Delete all [DELETE OPTION] </div> <div style="border: 1px solid black; padding: 5px;"> No Yes [DELETE STONE?] </div>
<p>Eliminazione di tutti i dettagli della gemma:</p> <ul style="list-style-type: none"> ⊖ Scorrere fino al record di una gemma ⊖ Premere “ENT” per confermare 		<div style="border: 1px solid black; padding: 5px;"> 1. Amber 2. Diamond 3. Opal [STONE DETAIL] </div>
<ul style="list-style-type: none"> • Premere “C” per eliminare 		

<ul style="list-style-type: none"> ⊖ Selezionare “Delete All” tra le opzioni di eliminazione e premere “ENT” per confermare ⊖ Selezionare “Yes” e premere “ENT” per confermare 		<div style="border: 1px solid black; padding: 5px; margin-bottom: 10px;"> <p>Delete ▲</p> <p>Delete all ▼</p> <p>[DELETE OPTION]</p> </div> <div style="border: 1px solid black; padding: 5px;"> <p>No ▲</p> <p>Yes ▼</p> <p>[DELETE STONE?]</p> </div>
--	---	---

g. Connettività PC

Il Presidium Gem Computer Gauge è dotato di un software scaricabile che consente l'accesso a una selezione di pietre preziose. per favore clicca su www.presidium.com.sg



Questo software non è attualmente compatibile con le piattaforme Mac OS.

3. LETTURA DEI RISULTATI DI UN TEST su Presidium Gem Computer Gauge

I valori S.G. delle gemme riportate in seguito vengono salvati all'interno di Presidium Gem Computer Gauge:

Pietre comuni (in ordine alfabetico)	
Albite feldspato	Nefrite
Alessandrite	Ossidiana
Granato almandino	Oligoclasio feldspato
Ambra	Opale
Andalusite	Ortoclasio
Granato andradite	Perla
Apatite	Olivina
Benitoite	Plastica
Berillo	Granato piropo
Brasilianite	Quarzo
Calcite	Rodocrosite
Calcedonio	Granato rodolite
Corallo	Rodonite
Corindone	Zaffiro
Ossido di zirconio cubico	Scapolite
Diamante	Serpentino
Danburite	Conchiglia
Diopside	Sinhalite
Dioptasio	Sodalite
Fluorite	Spodumene
Vetro	Granato spessartite
G.G.G.	Titanite
Ematite	Spinello

Idocrasio	Titanato di stronzio
Iolite	Smeraldo sintetico
Avorio	Rutilo sintetico
Giadeite	Spinello sintetico
Giaietto	Granato grossularia TL
Kornerupina	Topazio
Cianite	Tormalina
Labradorite feldspato	Granato grossularia TP
Lapislazuli	Turchese
Malachite	Verdite
Microclino	Y.A.G
Moldavite	Zircone (alto)
	Zircone (basso)
	Zircone (medio)
	Zoisite

4. MANUTENZIONE di Presidium Gem Computer Gauge

- Non lasciare le batterie esaurite nel vano delle batterie dal momento che potrebbero corrodersi o danneggiare il misuratore. Rimuovere le batterie quando si prevede di riporre il misuratore per un periodo di tempo prolungato.

Il misuratore è frutto di accurata progettazione e scrupolosa realizzazione e deve essere maneggiato con cautela.

Grazie per aver dedicato il tempo necessario a leggere la guida dell'utente contenente informazioni utili a comprendere meglio il prodotto appena acquistato.

Presidium consiglia inoltre di registrare la garanzia inviandoci la scheda di registrazione della garanzia o registrandosi on-line all'indirizzo <http://www.presidium.com.sg/>

**Руководство для
пользователей,
прибор Presidium
Gem Computer Gauge
(PGCG)**

Содержание

(Russian Version)

I. Руководство для пользователей	pg. 178
II. Прибор Presidium Gem Computer Gauge	pg. 179
III. ВАЖНЫЕ ИНСТРУКЦИИ ПО ТЕХНИКЕ БЕЗОПАСНОСТИ	pg. 185
1. ПОРЯДОК РАБОТЫ, прибор Presidium Gem Computer Gauge	pg. 187
2. ТЕСТИРОВАНИЕ, прибор Presidium Dial Gauge	pg. 189
a. Измерение	
b. функция «Weight Estimator» («Определитель веса»)	
c. СФункция «S.G. dictionary» («Справочник УВ»)	
d. Функция «Gemstone estimator» («Определитель веса»)	
e. Функция «Calculator» («Калькулятор»)	
f. Функция «Inventory» («Реестр»)	
g. Подключение к ПК	
3. РЕЗУЛЬТАТ ТЕСТИРОВАНИЯ, прибор Presidium Gem Computer Gauge	pg. 218
4. ТЕХ. ОБСЛУЖИВАНИЕ, прибор Presidium Gem Computer Gauge	pg. 220

I. Руководство для пользователей

Благодарим за покупку Presidium Gem Computer Gauge («PGCG» или «измерительный прибор»).

Данное руководство предназначено для того, чтобы помочь Вам настроить свой прибор, а также предоставить информацию о том, что Вы должны знать для правильного использования прибора и его обслуживания в соответствии с требованиями. Внимательно прочитайте данные инструкции и сохраняйте их в легкодоступном месте для использования в будущем.

II. Presidium Gem Computer Gauge

Прибор Presidium Gem Computer Gauge разработан в качестве улучшенной модели существующего прибора Presidium Electronic Gemstone Gauge, дополнен техническими характеристиками для выполнения большего количества функций, а именно:

- Измеряет действительные размеры драгоценных камней, определяет их вес и производит их идентификацию
- Измеряет 74 драгоценных камня и 9 форм огранки
- Точность измерения до 0,01 мм
- Прямое преобразование в караты для алмазов с круглой бриллиантовой огранкой
- Понятный и наглядный дисплей для удобного считывания показаний
- Легкий и переносной прибор, который можно использовать в любом месте
- Возможность подключения к ПК для быстрой передачи и распечатки результатов измерений

Технические характеристики:

Диапазон измерений: 0,00 – 25,00 мм или 0.000 - 57.343 карат

Рекомендуемый аккумулятор: CR 2450, 3 В, или аналогичный

Срок службы аккумулятора: как правило, составляет 26 часов непрерывного использования

Комплектация:

- Presidium Gem Computer Gauge
- Аккумулятор типа «CR-2450», 3 В
- Насадка для ювелирных изделий с высокой закрепкой
- Кабель USB
- Руководство для пользователей
- Гарантийный талон
- Футляр

Компоненты прибора

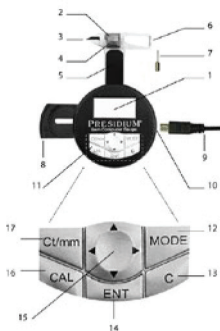

1	ЖК-дисплей
2	Площадка шперака
3	Клиновидные держатели
4	Ползунок
5	Платформа ползунка
6	Выступающий щуп
7	Насадка для ювелирных изделий
8	Батарейный отсек

9	Кабель USB
10	Порт USB
11	Клавиатура выбора
12	Кнопка «Mode» («Режим»)
13	Кнопка «Clear» («Сброс»)
14	Кнопка «Enter» («Ввод»)
15	Кнопка «Navigation» («Навигация»)
16	Кнопка активации «Calculator» («Калькулятор»)
17	Кнопка «Unit Conversion» («Преобразование единиц измерения»)



Конфигурация дисплея

ЖК-дисплей прибора PGCG, как правило, разделен на три секции.

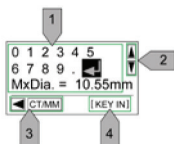

1. Интерактивный дисплей
2. Полоса прокрутки
3. Полоса инструкций

Конфигурация клавиатуры

См. таблицу ниже для ознакомления с функцией каждой кнопки на клавиатуре выбора. Некоторые кнопки используются для выполнения нескольких функций.

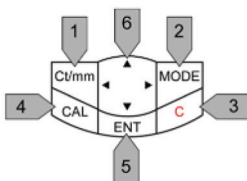

	Название	Стандартная функция	Дополнительная функция
1	Carat mm ↔ (Карат мм)	Нажмите, чтобы изменить единицу измерения миллиметр (мм) на единицу измерения (карат)	В режимах «Weight Estimator» («Определитель веса») и «Stone Estimator» («Определитель камня») нажмите эту кнопку для переключения «Measurement» («Измерение») на «Keypad» («Клавиатура») и наоборот, чтобы ввести размеры
2	Mode («Режим»)	Нажмите, чтобы вызвать меню выбора функций	

3	Cancel («Удалить»)	Нажмите, чтобы удалить данные	<ul style="list-style-type: none"> • Нажмите, чтобы включить прибор PGCG • В режиме «Measurement» («Измерение») нажмите эту кнопку, чтобы использовать функцию «tare/zero» (тара/нуль»)
4	Calculator («Калькулятор»)	Нажмите, чтобы активировать режим подсчета	В режиме «Weight Estimator» («Определитель веса») нажмите эту кнопку, чтобы подсчитать цену
5	Enter («Ввод»)	Нажмите, чтобы подтвердить выбор	
6	Клавиатура навигации	Нажмите, чтобы управлять данными на интерактивном дисплее	

III. ВАЖНЫЕ ИНСТРУКЦИИ ПО ТЕХНИКЕ БЕЗОПАСНОСТИ

- Храните измерительный прибор в сухом месте. Атмосферные осадки и все типы жидкости или влага могут содержать минералы, которые способствуют коррозии электронных схем. Если на прибор попала вода, то выньте из него аккумулятор. После того, как прибор тщательно просушили, заново вставьте аккумулятор.
- Запрещается использовать, хранить или устанавливать прибор в пыльных и грязных местах. Подвижные детали и электронные компоненты могут быть повреждены.
- Запрещается использовать, хранить или устанавливать прибор в жарких помещениях. Высокая температура может повредить или сократить срок службы измерительного прибора, испортить аккумулятор и деформировать или расплавить некоторые пластмассовые детали.
- Запрещается использовать, хранить или устанавливать измерительный прибор в холодных помещениях. При нагревании контрольно-измерительного прибора до нормальной температуры внутри прибора может конденсироваться влага. Это может повредить электронные платы.
- Открывайте крышку измерительного прибора только таким способом, который указан в руководстве.
- Запрещается ронять, ударять о поверхность или трясти измерительный прибор. Грубое обращение с прибором может привести к поломке внутренних микросхем и точной механики.

- Запрещается использовать агрессивные химические вещества, растворители или сильнодействующие моющие средства для очистки измерительного прибора.
- Запрещается красить измерительный прибор. Краска может блокировать подвижные детали и препятствовать правильному функционированию прибора.

В случае возникновения каких-либо сбоев при эксплуатации весов свяжитесь со службой технической поддержки компании Presidium по электронной почте service@presidium.com.sg или по адресу:

Presidium Instruments Pte Ltd
Unit 7, 207 Henderson Road
Singapore 159550
Attn: Customer Service Executive

1. НАЧАЛО РАБОТЫ, прибор Presidium Gem Computer Gauge

Установка аккумулятора в прибор Presidium Gem Computer Gauge

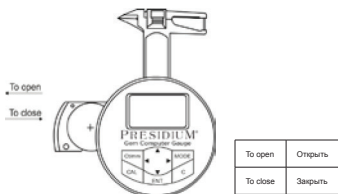

1. Выдвиньте наружу батарейный блок при помощи отвертки или вручную.
2. Установите аккумулятор типа «CR 2032», 3В, в батарейный отсек стороной с обозначением (+) вверх. Задвиньте батарейный блок внутрь прибора.
3. Рекомендуется использовать щелочные батарейки, поскольку они обеспечивают непрерывную эксплуатацию прибора на протяжении около двух с половиной часов. Если используются обычные батарейки, то прибор работает непродолжительное время.

Включение Presidium Gem Computer Gauge

1. Нажмите кнопку «С» («Удалить») на клавиатуре выбора.
2. На дисплее появится слово «Presidium», прибор автоматически перейдет в режим «Измерение».
3. На экране высветится две линии; первая относится к измерению в «мм», вторая линия – к измерению в «каратах».

Внимание: прибор PGCG автоматически выключится через 5 минут простоя.

Информация по эксплуатации аккумулятора

Не оставляйте использованные батарейки в батарейном отсеке, поскольку они могут корродировать, потечь или нанести ущерб измерительному прибору. Аккумулятор необходимо вынуть, если предполагается, что прибор будет храниться на протяжении длительного периода времени.

2. ТЕСТИРОВАНИЕ, прибор Presidium Gem Computer Gauge

1. По умолчанию после включения прибор будет работать в режиме «Measurement» («Измерение»).
2. PGCG поставляется с такими функциями:
 - a) «Measurement» («Измерение»)
 - b) «Weight Estimator» («Определитель веса»)
 - c) «Specific Gravity (S.G.) Dictionary» («Словарь «Удельный вес» (У.В.)»)
 - d) «Gemstone Estimator» («Определитель камня»)
 - e) «Calculator» («Калькулятор»)
 - f) «Inventory» («Реестр»)
 - g) Подключение к ПК
3. Чтобы использовать другие функции, нажмите кнопку «Mode» («Режим») на клавиатуре выбора и выберите функцию из списка.

а. Функция «Measurement» («Измерение»)

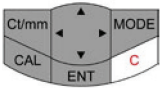
	Требование	Кнопка активации	Дисплей
1	<p>После включения прибор PGCG покажет размер (мм) и вес (карат):</p> <ol style="list-style-type: none"> 1. Нажмите кнопку «C» («Удалить»), чтобы включить прибор 		<p>0.00 mm 0.000 ct</p>

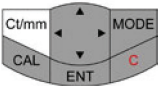
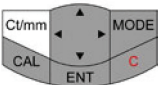
2	<p>Для показа только размера (мм):</p> <p>1. Нажмите кнопку «Ct/mm» («карат/мм»)</p>		0.00 mm
3	<p>Для показа только веса (карат):</p> <p>1. Нажмите кнопку «Ct/mm» («карат/мм»)</p>		0.000 ct

- Возьмите прибор Presidium Electronic Gem Gauge в любую руку. Управляйте ползунком при помощи большого пальца.

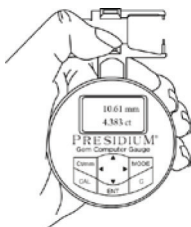

- Если необходимо измерить незакрепленные камни, потяните ползунок вниз и поместите камень на платформу ползунка. Основание камня должно быть параллельно платформе, чтобы он не двигался.

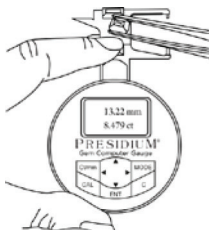

- Если необходимо измерить камни в оправе, вставьте насадку для ювелирных изделий в прибор и поместите камень между насадкой и ползунком шперака.



- Медленно задвиньте ползунок. На экране дисплея сразу появится показание.



- Нажмите кнопку «ct/mm» («карат/мм») для чередования следующего:
 1. Показать размер (мм) и вес (карат) (по умолчанию)
 2. Показать только размер (мм)
 3. Показать только вес (карат)

По умолчанию в приборе Presidium Gem Computer Gauge (PGCG) запрограммирован параметр для камней с круглой бриллиантовой огранкой (Американский стандарт).

Для получения параметров камней других форм выполните нижеприведенные инструкции.

в. Функция «Weight Estimator» («Определитель веса»)



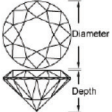
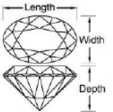
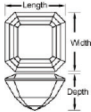
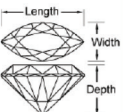
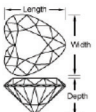
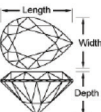
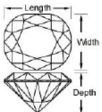
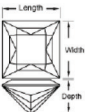
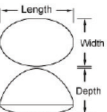

Прибор Presidium Gem Computer Gauge (PGCG) определяет вес камня, исходя из формы, диаметра, высоты и материала камня.

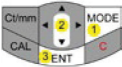
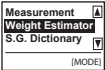

См. таблицу ниже, где показаны различные формы (огранки) камней:



		
Round	Oval	Emerald
		
Marquise	Heart	Pear
		
Cushion	Rectangle	Cabochon



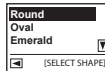

Round	Круглый
Oval	Овальный
Emerald	Изумруд
Marquise	Маркиз
Heart	Сердце
Pear	Косточка груши
Cushion	Подушка
Square	Квадратный
Cabochon	Кабошон

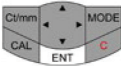
	Требование	Кнопка активации	Дисплей
1.	<p>Чтобы выбрать Weight Estimator («Определитель веса»):</p> <ul style="list-style-type: none"> ⊖ Выберите «Mode» («Режим») ⊖ Прокрутите до «Weight Estimator» («Определитель веса») ⊗ Нажмите «ENT» («ВВОД») для подтверждения 		

<p>2.</p>	<p>Чтобы выбрать New («Новый параметр») или Previous Setting («Предыдущий параметр»):</p> <ul style="list-style-type: none"> ⊖ Прокрутите полосу, чтобы выбрать ⊖ Нажмите «ENT» («ВВОД») для подтверждения 		
<p>3.1 Новый параметр</p>	<p>Чтобы выбрать название камня:</p> <ul style="list-style-type: none"> ⊖ Прокрутите полосу, чтобы выбрать название камня по первой букве в слове. ⊖ Нажмите «ENT» («ВВОД») для подтверждения 		

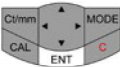
<p>Выберите камень:</p> <ul style="list-style-type: none"> ⊖ Прокрутите полосу, чтобы выбрать ⊖ Нажмите «ENT» («ВВОД») для подтверждения 		
<p>Чтобы выбрать форму:</p> <ul style="list-style-type: none"> ⊖ Прокрутите полосу, чтобы выбрать ⊖ Нажмите «ENT» («ВВОД») для подтверждения <p>Примечание: Вводимые размеры зависят от формы огранки камня. См. стр 192 для получения информации о формах (огранках) и соответствующих им требуемых размерах.</p>		

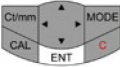
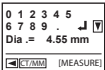
<p>3.2 Предыдущий параметр</p>	<p>Чтобы показать параметр предыдущего камня::</p> <ul style="list-style-type: none"> • Нажмите «ENT» («ВВОД») для подтверждения 		<div data-bbox="746 108 946 237" style="border: 1px solid black; padding: 5px;"> <p>Diamond Round</p> <p>[PREV. SETTING]</p> </div>
<p>4</p>	<p>Чтобы выбрать метод измерения:</p> <ul style="list-style-type: none"> ⊖ Прокрутите полосу, чтобы выбрать «measurement» («Измерение») или «keypad» («Клавиатура») <p>Нажмите «ENT» («ВВОД») для</p> <ul style="list-style-type: none"> ⊖ подтверждения 		<div data-bbox="746 609 946 737" style="border: 1px solid black; padding: 5px;"> <p>Measurement Keypad</p> <p>[SELECT INPUT]</p> </div>

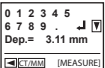
<p>4.1 Измерение²</p>	<p>Чтобы измерить диаметр:</p> <ul style="list-style-type: none"> • Поместите камень на площадку шперака • Нажмите «ENT» («ВВОД») для подтверждения 		
	<p>Чтобы измерить высоту:</p> <ol style="list-style-type: none"> 1. Поместите камень на площадку шперака 2. Нажмите «ENT» («ВВОД») для подтверждения 		
<p>4.2 Клавиатура</p>	<p>Ввод величины диаметра с клавиатуры:</p> <ul style="list-style-type: none"> ⊖ Введите величину диаметра камня ⊖ Чтобы подтвердить ввод данных, подведите курсор и нажмите «ENT» («ВВОД») 		

Чтобы ввести величину высоты с клавиатуры:

- ⊖ Введите величину высоты камня
- ⊖ Чтобы подтвердить ввод данных, подведите курсор ← и нажмите «ENT» («ВВОД»)

Помните, что каждый раз, когда вы нажимаете «Ct/mm» («карат/мм»), происходит чередование методов ввода «Keypad» («Клавиатура») и («Measurement») «Измерение».

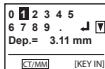

5. Суммарная информация о диаметре и высоте камня

- Нажмите «ENT» («ВВОД») для подтверждения

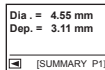
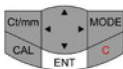

6.	<p>Расчетный вес камня появится на экране.</p> <p>На данном этапе работы пользователь может нажать «Ent» («ВВОД»), чтобы сохранить данные, или нажать «Cal» («Калькулятор»), чтобы посчитать стоимость. Ниже в пп. 6.1 и 6.2 предоставлена более подробная информация.</p>		<div data-bbox="774 89 974 220" style="border: 1px solid black; padding: 5px;"> <p>Diamond Round weight = 0.299 ct</p> <hr/> <p>◀ [CAL] [SUMMARY P2]</p> </div>
6.1 Сохранение данных	<p>Чтобы сохранить данные в реестре:</p> <ul style="list-style-type: none"> ⊖ Нажмите «ENT» («ВВОД») для сохранения данных ⊖ Прокрутите полосу, чтобы выбрать «YES/NO» («ДА/НЕТ») 		<div data-bbox="770 911 974 1042" style="border: 1px solid black; padding: 5px;"> <p>No</p> <p>Yes</p> <hr/> <p>◀ [SAVE STONE?] ▼</p> </div>

⊖ Если пользователь выберет «NO» («НЕТ»), то дисплей вернется к «Select Setting» («Выбрать параметр») для следующего измерения. Пользователь может выбрать параметр предыдущего камня или параметр нового камня.

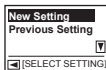

⊖ Нажмите «ENT» («ВВОД») для подтверждения

	<p>⊖ Если пользователь выбрал «YES» («ДА»), то подробная информация о камне будет сохранена в «Реестр»</p> <p>⊖ Нажмите «ENT» («ВВОД») для подтверждения. После сохранения данных дисплей вернется к «Select Setting» («Выбор параметра») для выполнения следующего измерения. Пользователь может выбрать параметр предыдущего камня или параметр нового камня.</p>		<div data-bbox="770 89 971 220" style="border: 1px solid black; padding: 5px;"> <p>Stone No. 1/16</p> <div style="text-align: right;">▼</div> <div style="display: flex; justify-content: space-between; align-items: center;"> ◀ [RECORD] </div> </div>
--	---	--	--

6.2 Подсчет цены

Чтобы посчитать стоимость камня:

- Нажмите «CAL» («Калькулятор»)

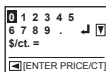
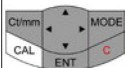

Ввод цены с клавиатуры:

- Чтобы
- ⊖ ввести данные, подведите курсор к выбранным данным и нажмите «ENT» («ВВОД»)

- Чтобы
- ⊖ подтвердить цену за карат, подведите курсор и нажмите «ENT» («ВВОД»)



Чтобы посчитать стоимость камня:

- Нажмите «CAL» («Калькулятор»)

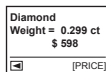

Чтобы сохранить данные в реестре:

- Нажмите «ENT» («ВВОД») для сохранения данных
- Прокрутите полосу, выберите вариант «YES» («ДА»), чтобы сохранить
- Нажмите «ENT» («ВВОД») для подтверждения
- После сохранения данных дисплей вернется к «Select Setting» («Выбор параметра») для выполнения следующего измерения.

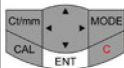





	<p>Помните, что сохраняются только параметры камня. Функция сохранения аналогична функции, описанной в п. 6.1 выше. Цена камня не сохраняется.</p>		
--	---	--	--

**с. «Specific Gravity (S.G.) Dictionary»
 («Словарь «Удельный вес» (У.В.)»)**

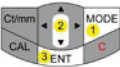
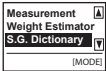
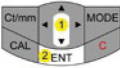
Прибор Presidium Gem Computer Gauge позволяет сузить поиск данных для идентификации камня, используя его удельный вес. Presidium Gem Computer Gauge (PGCG) снабжен справочником по величинам удельного веса (УД) выбранных камней для предоставления вам информации.

Помните, что для идентификации камня потребуется информация о весе камня из другого источника.

	Требование	Кнопка активации	Дисплей
1.	<p>Чтобы выбрать S.G. Dictionary («Справочник УВ»):</p> <ul style="list-style-type: none"> ⊖ Выберите «Mode» («Режим») ⊖ Прокрутите полосу до «S.G. Dictionary» («Справочник УВ»). ⊗ Нажмите «ENT» («ВВОД») для подтверждения 		
2.	<p>Чтобы выбрать название камня:</p> <p>Прокрутите</p> <ul style="list-style-type: none"> ⊖ полосу, чтобы выбрать название камня по первой букве в слове <p>Нажмите</p> <ul style="list-style-type: none"> ⊖ «ENT» («ВВОД») для подтверждения 		

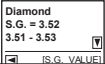
<p>3.</p>	<p>Чтобы выбрать камень:</p> <ul style="list-style-type: none"> ⊖ Прокрутите полосу, чтобы выбрать ⊖ Нажмите «ENT» («ВВОД») для подтверждения 		
<p>4</p>	<p>Величина УВ выбранного камня появится на дисплее</p>		



d. «Gemstone Estimator» («Определитель камня»)

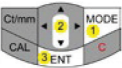
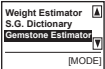

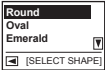

Процедура определения величины удельного веса (УВ) тестируемого камня:

	Требование	Кнопка активации	Дисплей
<p>1.</p>	<p>Чтобы выбрать Weight Estimator («Определитель веса»):</p> <ul style="list-style-type: none"> ⊖ Выберите «Mode» («Режим») ⊖ Прокрутите полосу до «Gemstone Estimator» («Определитель камня») 		

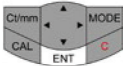
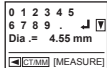
	<ul style="list-style-type: none"> ⊗ Нажмите «ENT» («ВВОД») для подтверждения 		
--	--	--	--

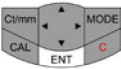
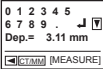
<p>2. Чтобы выбрать форму³:</p> <ul style="list-style-type: none"> ⊖ Прокрутите полосу, чтобы выбрать ⊖ Нажмите «ENT» («ВВОД») для подтверждения <p>³Для ознакомления с изображениями форм см. стр. 192</p> <p>⁴Вводимые размеры зависят от формы (огранки) камня. См. стр 192 для получения информации о формах и соответствующих им требуемых размерах.</p>			
--	---	---	--

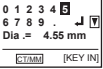
<p>3.</p>	<p>Чтобы выбрать метод измерения:</p> <ul style="list-style-type: none"> ⊖ Прокрутите полосу, чтобы выбрать «measurement» («измерение») или «keypad» («клавиатура») <p>Нажмите «ENT» («ВВОД»)</p> <ul style="list-style-type: none"> ⊖ для подтверждения 		
<p>3.1 Измерение ⁴</p>	<p>Чтобы измерить диаметр:</p> <ul style="list-style-type: none"> • Поместите камень на площадку шперака • Нажмите «ENT» («ВВОД») для подтверждения 		

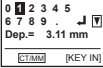
	<p>Чтобы измерить высоту:</p> <ul style="list-style-type: none"> • Поместите камень на площадку шперака • Нажмите «ENT» («ВВОД») для подтверждения 		
<p>3.2 Клавиатура</p>	<p>Чтобы ввести величину диаметра с клавиатуры:</p> <ul style="list-style-type: none"> ⊖ Введите величину диаметра камня ⊕ Чтобы подтвердить ввод данных, подведите курсор ← и нажмите «ENT» («ВВОД») 		
	<p>Чтобы ввести величину высоты с клавиатуры:</p>		

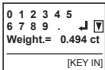
	<p>⊖ Введите величину высоты камня</p> <p>⊖ Чтобы подтвердить ввод данных, подведите курсор и нажмите «ENT» («ВВОД»)</p> <p>Помните, что каждый раз, когда вы нажимаете «Ct/mm» («карат/мм»), происходит чередование методов ввода «Keypad» («Клавиатура») и («Measurement») «Измерение».</p>		
4	<p>Чтобы ввести величину веса с клавиатуры:</p> <p>Введите</p> <p>⊖ величину веса камня</p>		

	<p>⊖ Чтобы подтвердить ввод данных, подведите курсор и нажмите «ENT» («ВВОД»)</p>		
5	<p>Величина УД камня будет вычислена. Будет показан список камней⁵ со связанным значением УД</p> <p>⁵См. стр. 218-219 для ознакомления со списком камней, информация о которых введена в PGCG</p>		

e. Calculator («Калькулятор»)

Прибор Presidium Gem Computer Gauge (PGCG) также позволяет производить простые вычисления.

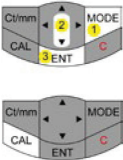
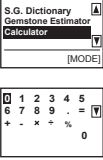

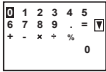
	Требование	Кнопка активации	Дисплей
1.	<p>Чтобы выбрать Calculator («Калькулятор»):</p> <p>Выберите ⊖ «Mode» («Режим»)</p>		

	<p>⊖ Прокрутите полосу до «Calculator» («Калькулятор»)</p> <p>Нажмите</p> <p>⊗ «ENT» («ВВОД») для подтверждения или нажмите кнопку «CAL»</p>		
2	<p>Калькуляция:</p> <p>Для ввода данных подведите курсор к необходимым данным и нажмите «ENT» («ВВОД»)</p>		

f. Функция «Inventory» («Реестр»)

Прибор Presidium Gem Computer Gauge (PGCG) позволяет сохранять информацию (например, данные об идентификации камня, форме и весе) о камне в справочных целях.

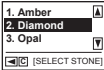
	Требование	Кнопка активации	Дисплей
1.	<p>Чтобы выбрать Inventory («Реестр»):</p> <p>⊖ Выберите «Mode» («Режим»)</p>		

	<p>⊖ Прокрутите полосу до «Inventory» («Реестр»)</p> <p>⊗ Нажмите «ENT» («ВВОД») для подтверждения</p>		
2.	<p>Список камней, сохраненных в памяти, будет отображаться на дисплее</p>		
3.	<p>Чтобы выбрать данные о камне:</p> <p>Прокрутите ⊖ полосу, чтобы выбрать</p> <p>Нажмите ⊖ «ENT» («ВВОД») для подтверждения</p>		

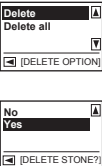
<p>4</p> <p>Чтобы удалить данные о выбранном камне:</p> <ul style="list-style-type: none"> ⊖ Прокрутите полосу, чтобы выбрать запись о камне, которую необходимо удалить ⊖ Нажмите «ENT» («ВВОД») для подтверждения 		
<ul style="list-style-type: none"> • Нажмите кнопку «C» («Удалить»), чтобы удалить 		
<ul style="list-style-type: none"> ⊖ Выберите «Delete» («Удалить») из предлагаемых вариантов удаления и нажмите «ENT» («ВВОД») для подтверждения 		

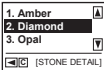
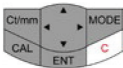
<ul style="list-style-type: none"> ⊖ Выберите «Yes» («Да») и нажмите «ENT» («ВВОД») для подтверждения 		
<p>Чтобы удалить все данные о выбранном камне:</p> <ul style="list-style-type: none"> ⊖ Прокрутите полосу до любой записи о камне ⊖ Нажмите «ENT» («ВВОД») для подтверждения 		
<ul style="list-style-type: none"> • Нажмите кнопку «C» («Удалить»), чтобы удалить 		

<p>⊖ Выберите «Delete All» («Удалить все») из предлагаемых вариантов удаления и нажмите «ENT» («ВВОД») для подтверждения</p> <p>Выберите «Yes»</p> <p>⊖ («Да») и нажмите «ENT» («ВВОД») для подтверждения</p>		 
---	--	---

g. Подключение к ПК

Президиум Gem Computer Gauge поставляется с загружаемым программным обеспечением, обеспечивающим доступ к выбору большего количества драгоценных камней. нажмите на www.presidium.com.sg



В настоящее время это программное обеспечение еще не совместимо с платформами Mac OS.

3. РЕЗУЛЬТАТЫ ТЕСТИРОВАНИЯ, прибор Presidium Gem Computer Gauge

Значения удельного веса Следующих камней находятся в памяти прибора Presidium Gem Computer Gauge:

Список распространенных драгоценных и полудрагоценных камней (в алфавитном порядке)	
Полевой шпат альбит	Нефрит
Александрит	Обсидиан
Гранат альмандин	Полевой шпат олигоклаз
Янтарь	Опал
Андалузит	Ортоклаз
Андрадит гранат	Жемчуг
Апатит	Перидот
Бенитоит	Пластик
Берилл	Гранат пироп
Бразиллианит	Кварц
Кальцит	Родохрозит
Халцедон	Гранат родолит
Коралл	Родонит
Корунд	Сапфир
Кубический диоксид циркония	Скаполит
Бриллиант	Серпентин
Данбурит	«Раковина» (оперкулумом)
Диопсид	Сингалит
Диоптаз	Содалит
Флюорит	Сподумен
Стекло	Гранат спессатрин

Гадолиний-галлиевый гранат	Титанит
Гематит	Титанат стронция
Идокраз	Искусственный изумруд
Иолит	Искусственный рутил
Слоновая кость	Искусственный шпинель
Жадеит	TL гранат гроссуляр
Гагат	Топаз
Корнерупин	Турмалин
Кианит	TR гранат гроссуляр (эссонит)
Лабрадор	Бирюза
Лазурит	Вердит
Малахит	АИГ (Алюмоиттриевый гранат)
Микроклин	Циркон (с высоким показателем дисперсии)
Молдавит	Циркон (с низким показателем дисперсии)
	Циркон (со средним показателем дисперсии)
	Цоизит

4. ТЕХ. ОБСЛУЖИВАНИЕ, прибор Presidium Gem Computer Gauge

- Не оставляйте использованные батарейки в батарейном отсеке, поскольку они могут корродировать, потечь или нанести ущерб измерительному прибору. Аккумулятор необходимо вынуть, если предполагается, что прибор будет храниться на протяжении длительного периода времени.

Данный прибор отличается сложной конструкцией и высоким уровнем исполнения, поэтому при работе с ним следует соблюдать осторожность.

Благодарим Вас, что Вы уделили время для прочтения руководства для пользователей. Это позволит Вам лучше понять ценность приобретенного товара.

Компания Presidium также рекомендует зарегистрировать гарантию, отправив регистрационный гарантийный талон, или зарегистрироваться на веб-сайте <http://www.presidium.com.sg/>.

**Manual del usuario
para el Presidium
Gem Computer Gauge
(PGCG)**

Contenido

(Spanish Version)

I.	Acerca de este manual	pg. 223
II.	Acerca del Presidium Gem Computer Gauge	pg. 224
III.	AVISO IMPORTANTE	pg. 228
1.	PRIMEROS PASOS con su Presidium Gem Computer Gauge	pg. 230
2.	REALIZAR UNA PRUEBA con su Presidium Gem Computer Gauge	pg. 232
	a. Medición	
	b. Estimador de peso	
	c. Diccionario de gravedad específica (G.E.)	
	d. Estimador de piedras preciosas	
	e. Calculadora	
	f. Inventario	
	g. Conectividad con el PC	
3.	LECTURA DE LOS RESULTADOS DE LA PRUEBA en su Presidium Gem Computer Gauge	pg. 254
4.	CUIDADO del Presidium Gem Computer Gauge	pg. 256

I. Acerca de este manual

Gracias por comprar el Presidium Gem Computer Gauge (“PGCG” o “medidor”).

Este manual está diseñado para ayudarle a instalar su medidor, y describe todo lo que necesita saber sobre cómo utilizar el medidor de forma precisa y cuidarlo según sus requisitos. Lea estas instrucciones cuidadosamente y manténgalas a mano para referencia futura.

II. Acerca del Presidium Gem Computer Gauge

El Presidium Gem Computer Gauge se ha desarrollado como una extensión del medidor electrónico de piedras preciosas Presidium existente, con las características adicionales de realizar más funciones, entre las que se incluyen:

- Mide dimensiones de piedras preciosas reales y estima el peso y la identidad de la piedra preciosa
- Mide 74 piedras preciosas y 9 formas diferentes
- Medición precisa de hasta 0,01 mm
- Conversión directa a quilates de diamantes redondos brillantes
- Pantalla clara y visible para una fácil lectura de las mediciones
- Instrumento liviano y portátil que puede utilizarse en cualquier parte
- Conectividad con el PC para una fácil importación e impresión de los resultados de las mediciones

Especificaciones del producto:

Rango de medición: 0,00 mm a 25,00 mm o 0,000 ct a 57,343 ct

Batería recomendada: CR 2450 de 3 V o equivalente

Duración de la batería: por lo general, aproximadamente 26 horas de uso continuo

Contenido del envase:

- Presidium Gem Computer Gauge
- Batería de 3 V CR-2450
- Accesorio para joyas de ajuste alto
- Cable USB
- Manual de usuario
- Tarjeta de garantía
- Caja de protección

Piezas del medidor

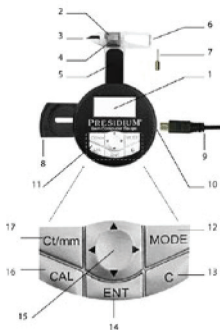

1	Pantalla LCD
2	Yunque base
3	Puntas con forma de cuña
4	Mecanismo de deslizamiento
5	Plataforma deslizante
6	Sonda sobresaliente
7	Accesorio para joyas
8	Compartimiento de las pilas
9	Cable USB
10	Puerto USB
11	Teclado de selección
12	Botón de Modo
13	Botón Borrar
14	Botón Intro
15	Botón Navegación
16	Botón Activación de la calculadora
17	Botón Conversión de unidades

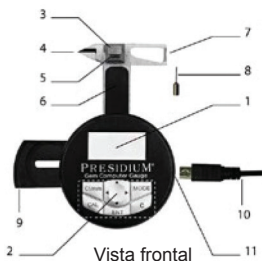

Configuración de la pantalla

La pantalla LCD del PGCG generalmente está dividida en tres secciones.

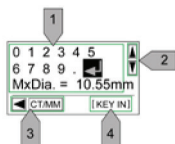

1. Pantalla interactiva
2. Barra de desplazamiento
3. Barra de instrucciones

Configuración del teclado

Consulte la tabla mostrada a continuación para conocer la función de cada tecla en el teclado de selección. Algunas teclas tendrán más de una función.

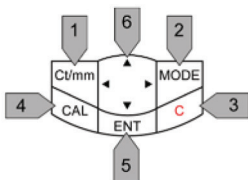

	Nom- bre	Función normal	Función adicional
1	Quilates ↔ mm	Pulse para cambiar la unidad de medida entre milímetros (mm) y quilates (Ct)	En el modo “Estimador de peso” y “Estimador de piedra”, pulse para cambiar entre “Medición” y “Teclado” para ingresar la dimensión
2	Modo	Pulse para visualizar el menú de selección de funciones	
3	Can- celar	Pulse para eliminar los elementos	<ul style="list-style-type: none"> • Pulse para volver a PGCG • En el modo “Medición”, pulse para la función tara/puesta a cero
4	Calcula- dora	Pulse para activar el modo de calculadora	En el modo “Estimador de peso”, pulse para realizar el cálculo del precio
5	Intro	Pulse para eliminar la selección	
6	Teclado de nave- gación	Pulse para navegar por los datos en la pantalla interactiva	

III. AVISO IMPORTANTE

- Mantenga seco el medidor. La precipitación y todos los tipos de líquidos o humedad pueden contener minerales que generen corrosión en los circuitos eléctricos. Si su medidor se moja, extraiga la pila y permita que el medidor se seque completamente antes de volver a colocarla.
- No utilice, almacene ni exponga el medidor a áreas sucias o con abundante polvo. Sus piezas móviles y los componentes electrónicos pueden dañarse.
- No utilice, almacene ni exponga el medidor a áreas calientes. Las altas temperaturas pueden dañar o acortar la vida útil del probador, dañar las pilas y deformar o derretir ciertos plásticos.
- No utilice, almacene ni exponga el medidor a áreas frías. Cuando el probador vuelve a su temperatura normal, se puede formar humedad dentro del mismo y dañar las placas de circuito electrónico.
- No intente abrir el medidor de una manera que no sea la que se indica en este manual.
- No deje caer, golpee o sacuda el medidor. La manipulación brusca puede romper las placas de circuito interno y los mecanismos de precisión.
- No utilice productos químicos fuertes, ni solventes de limpieza ni detergentes fuertes para limpiar el medidor.
- No pinte el medidor. La pintura puede obstruir las piezas móviles y evitar un funcionamiento correcto.

Si el medidor no funciona adecuadamente, póngase en contacto con el Servicio de atención al cliente de Presidium escribiendo un correo electrónico a service@presidium.com.sg o por correo postal a la dirección:

Presidium Instruments Pte Ltd
Unit 7, 207 Henderson Road
Singapore 159550
Attn: Customer Service Executive

1. PRIMEROS PASOS con su Presidium Gem Computer Gauge

Inserción de la batería en el Presidium Gem Computer Gauge



1. Tire del lateral deslizante de la batería hacia fuera con las uñas o un destornillador.
2. Coloque la batería CR 2450 de 3 V con el signo (+) hacia arriba en el compartimiento para pilas y ciérrelo empujando el lateral deslizante de la batería hacia adentro.
3. Se prefiere el uso de pilas alcalinas, ya que suelen permitir unas dos horas y media de uso continuo, mientras que el uso de pilas normales proporciona una vida de trabajo más corta.

Encendido del Presidium Gem Computer Gauge

1. Pulse el botón "C" en el teclado de selección.
2. La palabra "Presidium" aparecerá y el dispositivo pasará automáticamente al modo "Medición".
3. La pantalla mostrará dos líneas; la primera es la medición en unidad de milímetros y la segunda línea es la medición en unidades de quilates.

Tenga en cuenta que el PGCG se apagará automáticamente después de 5 minutos de inactividad.

Información de las pilas

No deje pilas gastadas dentro del compartimiento para pilas, ya que estas pueden corroerse, tener fugas o dañar el medidor. Las pilas deberán retirarse cuando el instrumento se vaya a almacenar durante un período extendido.

2. REALIZAR UNA PRUEBA con su Presidium Gem Computer Gauge

1. De manera predeterminada, al encenderse, el dispositivo estará en modo "Medición".
2. El PGCG posee las siguientes funciones:
 - a) Medición
 - b) Estimador de peso
 - c) Diccionario de gravedad específica (G.E.)
 - d) Estimador de piedra preciosa
 - e) Calculadora
 - f) Inventario
 - g) Conectividad con el PC
3. Para utilizar las demás funciones, pulse "Modo" en el teclado de selección y escoja una función de la lista.

a. Medición

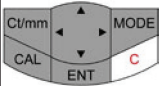
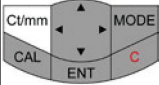
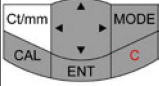
	Medición	Tecla de activación	Visualización
1	Al encenderlo, el PGCG mostrará la dimensión en mm y el peso en quilates: 1. Pulse "C" para encender		0,00 mm 0,000 ct
2	Para mostrar solo la dimensión en mm: 1. Pulse "Ct/mm"		0,00 mm
3	Para mostrar solo el peso en quilates: 1. Pulse "Ct/mm"		0,000 ct

- El Presidium Gem Computer Gauge debe sostenerse en la palma de la mano. Controle el mecanismo deslizando con el pulgar.

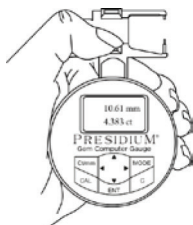

- Cuando mida piedras sueltas, empuje el mecanismo de deslizamiento y coloque la piedra en la plataforma del mecanismo de deslizamiento. La base de la piedra debe estar en paralelo con respecto a la plataforma, para evitar que se mueva.

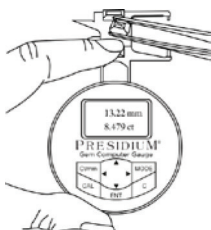

- Al medir piedras montadas, inserte el accesorio para joyas en el medidor y coloque la piedra entre el accesorio para joyas y el yunque deslizable.



- Cierre lentamente el mecanismo de deslizamiento. La lectura se mostrará inmediatamente en la ventana.



- Pulse “ct/mm” para alternar entre las siguientes pantallas:
 1. Visualización de la dimensión en mm y el peso en quilates (predeterminado)
 2. Visualización de la dimensión en mm solamente
 3. Visualización del peso en quilates solamente

El ajuste predeterminado del Presidium Gem Computer Gauge (PGCG) está programado para el estándar americano de corte redondo brillante

Para otras piedras preciosas de otras formas, directamente realice los siguientes pasos.





b. Estimador de peso

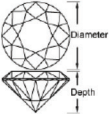
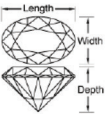
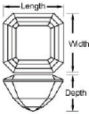
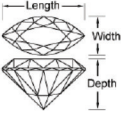
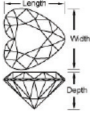
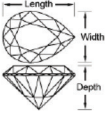
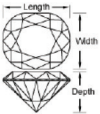
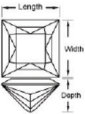
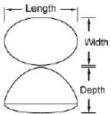

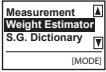
El Presidium Gem Computer Gauge (PGCG) estima el peso de la piedra preciosa a partir de su forma, diámetro, profundidad y naturaleza.



Las diferentes formas de las piedras preciosas se muestran en el diagrama a continuación:

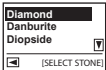

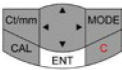
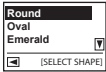
		
Round	Oval	Emerald
		
Marquise	Heart	Pear
		
Cushion	Rectangle	Cabochon

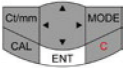
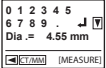
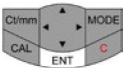
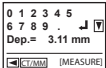

	Requisito	Tecla de activación	Visualización
1.	<p>Seleccione Estimador de peso:</p> <ul style="list-style-type: none"> ⊖ Seleccione Modo ⊖ Desplácese hasta Estimador de peso ⊗ Pulse "INTR" para confirmar 		

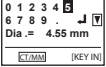
<p>2.</p>	<p>Seleccione Nuevo ajuste anterior:</p> <ul style="list-style-type: none"> ⊖ Desplácese para seleccionar ⊖ Pulse “INTR” para confirmar 		
<p>3.1 Ajuste nuevo</p>	<p>Seleccione el nombre de la piedra preciosa:</p> <ul style="list-style-type: none"> ⊖ Desplácese para seleccionar el nombre de la piedra preciosa por la primera letra. ⊖ Pulse “INTR” para confirmar 		
	<p>Seleccione una piedra preciosa:</p> <ul style="list-style-type: none"> ⊖ Desplácese para seleccionar ⊖ Pulse “INTR” para confirmar 		
	<p>Seleccione una forma:</p> <ul style="list-style-type: none"> ⊖ Desplácese para seleccionar 		

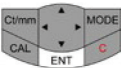
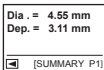

	<p>Pulse "INTR" para confirmar</p> <p>Nota: Las diferentes dimensiones que se ingresarán dependen de la forma de la piedra preciosa. Consulte la página 235 para obtener la forma y sus correspondientes dimensiones necesarias.</p>		
<p>3.2 Ajuste anterior</p>	<p>Se mostrará el ajuste anterior de la piedra preciosa:</p> <ul style="list-style-type: none"> • Pulse "INTR" para confirmar 		
<p>4</p>	<p>Seleccione el método de medición:</p> <ul style="list-style-type: none"> ⊖ Desplácese para seleccionar desde medición o teclado ⊖ Pulse "INTR" para confirmar 		

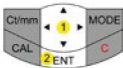
<p>4.1 M Medición²</p>	<p>Medición del diámetro:</p> <ul style="list-style-type: none"> • Coloque el diámetro de la piedra preciosa en el yunque base • Pulse “INTR” para confirmar 		
	<p>Medición de la profundidad:</p> <ol style="list-style-type: none"> 1. Coloque la profundidad de la piedra preciosa en el yunque base 2. Pulse “INTR” para confirmar 		
<p>4.2 Teclado</p>	<p>Escritura del diámetro:</p> <ul style="list-style-type: none"> ⊖ Escriba el diámetro de la piedra preciosa ⊖ Para confirmar la entrada, vaya con el cursor hasta ← y pulse “INTR” 		

	<p>Escritura de la profundidad:</p> <ul style="list-style-type: none"> ⊖ Escriba la profundidad de la piedra preciosa ⊖ Para confirmar la entrada, vaya con el cursor hasta ← y pulse “INTR” <p>Tenga en cuenta que en cualquier momento, pulsar Ct/mm cambiará entre los métodos de entrada “Teclado” o “Medición”</p>		
5.	<p>Resumen del diámetro y la profundidad de la piedra preciosa.</p> <ul style="list-style-type: none"> • Pulse “INTR” para confirmar 		

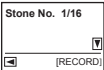
6.	<p>Se mostrará el peso estimado de la piedra preciosa. En este punto, el usuario puede pulsar “Intr” para almacenar o “Cal” para el cálculo del precio. La información detallada se proporciona en 6.1 y 6.2 a continuación</p>		<div data-bbox="743 89 943 216" style="border: 1px solid black; padding: 5px;"> <p>Diamond Round weight = 0.299 ct</p> <p>◀ [CAL] [SUMMARY P2]</p> </div>
	<p>Almacenamiento de datos en el inventario:</p> <ul style="list-style-type: none"> ⊖ Pulse “INTR” para almacenar los datos ⊖ Desplácese para seleccionar “SÍ/NO” 		<div data-bbox="738 697 943 825" style="border: 1px solid black; padding: 5px;"> <p>No Yes</p> <p>▶</p> <p>◀ [SAVE STONE?]</p> </div>
6.1 Almacenamiento de datos	<ul style="list-style-type: none"> ⊖ Si el usuario selecciona “NO”, la pantalla volverá a “Seleccionar ajuste” para la siguiente medición. 		<div data-bbox="738 1281 943 1410" style="border: 1px solid black; padding: 5px;"> <p>New Setting Previous Setting</p> <p>▶</p> <p>◀ [SELECT SETTING]</p> </div>

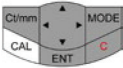
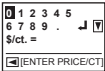
6.1 Almacenamiento de datos	<p>⊖ El usuario tendrá la libertad de escoger entre los ajustes de piedras anterior o nuevo.</p> <p>Pulse “INTR” para confirmar</p>		
	<p>⊖ Si el usuario selecciona “SÍ”, los detalles de la piedra preciosa se almacenarán en “Inventario”</p> <p>⊖ Pulse “INTR” para confirmar</p> <p>Al almacenar los datos, la pantalla volverá a “Seleccionar ajuste” para la siguiente medición. El usuario tendrá la libertad de escoger entre los ajustes de piedras anterior o nuevo.</p>		 <p>Stone No. 1/16</p> <p>[RECORD]</p>

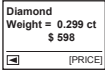
6.2 Cálculo del precio	<p>Cálculo del precio de la piedra preciosa:</p> <ul style="list-style-type: none"> • Pulse “CAL” 		
	<p>Escritura del precio:</p> <ul style="list-style-type: none"> ⊖ Para el ingreso de los datos, navegue con el cursor hasta ← seleccione los datos y pulse “INTR” ⊖ Para confirmar el precio por quilate, vaya con el cursor hasta, y pulse “INTR” 		
	<p>Se mostrará el precio de la piedra preciosa</p>		

Almacenamiento de datos en el inventario:

- Pulse “INTR” para almacenar los datos
- Desplácese para seleccionar “SÍ” en la opción de almacenar
- Pulse “INTR” para confirmar
- Al almacenar los datos, la pantalla volverá a “Seleccionar ajuste” para la siguiente medición

Tenga en cuenta que se almacenan solo los ajustes de la piedra. La función de almacenamiento es similar a la sección 6.1 anterior. Se almacenará el precio de la piedra preciosa.

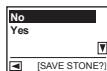
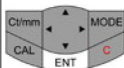



c. Diccionario de gravedad específica (G.E.)

El Presidium Gem Computer Gauge le permite acotar una piedra preciosa por su G.E. El Presidium Gem Computer Gauge (PGCG) incluye un diccionario para los valores de G.E. de piedras preciosas seleccionadas para su referencia.

Tenga en cuenta que será necesario contar con el peso de la piedra preciosa de otra fuente para la identificación de la piedra preciosa.

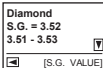

	Requisito	Tecla de activación	Visua- lización
1.	<p>Seleccione Diccionario de G.E.:</p> <ul style="list-style-type: none"> ⊖ Seleccione Modo ⊖ Desplácese hasta Diccionario de G.E. ⊗ Pulse “INTR” para confirmar 		
2.	<p>Seleccione el nombre de la piedra preciosa:</p> <ul style="list-style-type: none"> ⊖ Desplácese para seleccionar el nombre de la piedra preciosa por la primera letra. ⊖ Pulse “INTR” para confirmar 		



<p>3.</p>	<p>Seleccione una piedra preciosa:</p> <ul style="list-style-type: none"> ⊖ Desplácese para seleccionar ⊖ Pulse “INTR” para confirmar 		
<p>4</p>	<p>Se mostrará el valor de la G.E. de la piedra preciosa seleccionada</p>		

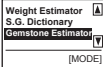

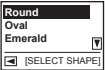
d. Estimador de piedra preciosa

Para determinar la G.E. de la piedra preciosa que se probará:

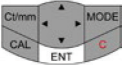
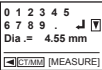
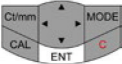
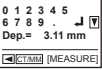
	Requisito	Tecla de activación	Visua- lización
<p>1.</p>	<p>Seleccione Estimador de piedra preciosa:</p> <ul style="list-style-type: none"> ⊖ Seleccione Modo ⊖ Desplácese hasta Estimador de piedra preciosa ⊗ Pulse “INTR” para confirmar 		

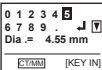
<p>2.</p>	<p>Seleccione una forma³:</p> <ul style="list-style-type: none"> ⊖ Desplácese para seleccionar ⊖ Pulse “INTR” para confirmar <p>³Consulte la página 235 para ver la imagen de las formas.</p> <p>⁴Las diferentes dimensiones que se ingresarán dependen de la forma de la piedra preciosa. Consulte la Página 235 para obtener las diferentes formas y sus correspondientes dimensiones necesarias.</p>		
<p>3.</p>	<p>Seleccione el método de medición:</p> <ul style="list-style-type: none"> ⊖ Desplácese para seleccionar desde medición o teclado 		

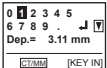
	<p>⊖ Pulse “INTR” para confirmar</p>		
3.1 Medición ⁴	<p>Medición del diámetro:</p> <ul style="list-style-type: none"> • Coloque el diámetro de la piedra preciosa en el yunque base • Pulse “INTR” para confirmar 		
	<p>Medición de la profundidad:</p> <ul style="list-style-type: none"> • Coloque la profundidad de la piedra preciosa en el yunque base • Pulse “INTR” para confirmar 		
3.2 Teclado	<p>Escritura del diámetro:</p> <ul style="list-style-type: none"> ⊖ Escriba la profundidad de la piedra preciosa ⊖ Para confirmar la entrada, vaya con el cursor hasta \leftarrow y pulse “INTR” 		

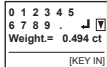
	<p>Escritura de la profundidad:</p> <ul style="list-style-type: none"> ⊖ Escriba la profundidad de la piedra preciosa ⊖ Para confirmar la entrada, vaya con el cursor hasta, y pulse “INTR” <p>Tenga en cuenta que en cualquier momento, pulsar Ct/mm cambiará entre los métodos de entrada “Teclado” o “Medición”</p>		
4	<p>Escritura del peso:</p> <ul style="list-style-type: none"> ⊖ Escriba el peso de la piedra preciosa ⊖ Para confirmar la entrada, vaya con el cursor hasta, y pulse “INTR” 		

5	<p>Se calculará el valor de la G.E. de la piedra preciosa. Se mostrará la lista de piedras preciosas⁵ con su valor de G.E. asociado</p> <p>⁵Consulte la página 254-255 para obtener la lista de piedras preciosas incluidas en PGCG</p>		
---	---	--	--

e. Calculadora

El Presidium Gem Computer Gauge (PGCG) también le permite realizar cálculos simples.

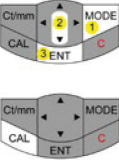
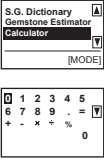

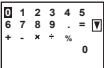
	Requisito	Tecla de activación	Visualización
1.	<p>Seleccione Calculadora:</p> <ul style="list-style-type: none"> ⊖ Seleccione Modo ⊖ Desplácese hasta Calculadora ⊗ Pulse "INTR" para confirmar o, pulse "CAL" para seleccionar la Calculadora 		

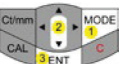
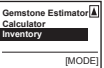
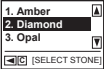

2.	Cálculo: <ul style="list-style-type: none"> Para la entrada de datos, vaya con el cursor para seleccionar los datos y pulse "INTR" 		
----	--	---	--

f. Inventario

El Presidium Gem Computer Gauge (PGCG) le permite almacenar detalles (p. ej. identidad de la piedra preciosa, forma y peso) de las piedras preciosas para su referencia.

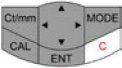
	Requisito	Tecla de activación	Visualización
1.	Seleccione Inventario: <ul style="list-style-type: none"> ⊖ Seleccione Modo ⊖ Desplácese hasta Inventario ⊗ Pulse "INTR" para confirmar 		
2.	Se enumerarán todas las piedras preciosas almacenadas en la memoria		

<p>3.</p>	<p>Seleccione los detalles de la piedra preciosa:</p> <ul style="list-style-type: none"> ⊖ Desplácese para seleccionar ⊖ Pulse “INTR” para confirmar 		<div style="border: 1px solid black; padding: 5px;"> <p>2. Diamond ▲</p> <p>Oval</p> <p>Weight = 6.23 ct ▼</p> <p>◀ C [STONE DETAIL]</p> </div>
<p>4</p>	<p>Eliminación de los detalles de la piedra preciosa seleccionada:</p> <ul style="list-style-type: none"> ⊖ Desplácese hasta el registro de la piedra preciosa seleccionada que desea eliminar ⊖ Pulse “INTR” para confirmar 		<div style="border: 1px solid black; padding: 5px;"> <p>1. Amber ▲</p> <p>2. Diamond ▼</p> <p>3. Opal ▼</p> <p>◀ C [SELECT STONE]</p> </div>
<ul style="list-style-type: none"> • Pulse “C” para eliminar 			

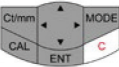
	<p>⊖ Seleccione “Eliminar” de la opción en eliminación y pulse “INTR” para confirmar</p> <p>⊖ Seleccione “Sí” y pulse “INTR” para confirmar</p>		<div data-bbox="729 89 930 220"> <p>Delete</p> <p>Delete all</p> <p>[DELETE OPTION]</p> </div> <div data-bbox="729 282 930 412"> <p>No</p> <p>Yes</p> <p>[DELETE STONE?]</p> </div>
	<p>Eliminación de todos los detalles de la piedra preciosa:</p> <p>Desplácese</p> <p>⊖ hasta cualquier registro de piedra preciosa</p> <p>Pulse “INTR”</p> <p>⊖ para confirmar</p>		<div data-bbox="729 690 930 821"> <p>1. Amber</p> <p>2. Diamond</p> <p>3. Opal</p> <p>[STONE DETAIL]</p> </div>
	<ul style="list-style-type: none"> • Pulse “C” para eliminar 		

	<ul style="list-style-type: none"> ⊖ Seleccione “Eliminar todo” de la opción de eliminación y pulse “INTR” para confirmar ⊖ Seleccione “Sí” y pulse “INTR” para confirmar 		<div style="border: 1px solid black; padding: 5px; margin-bottom: 10px;"> Delete ▲ Delete all ▼ [DELETE OPTION] </div> <div style="border: 1px solid black; padding: 5px;"> No ▲ Yes ▼ [DELETE STONE?] </div>
--	---	--	---

g. Conectividad con el PC

El medidor de computadora Presidium Gem viene con un software descargable que proporciona acceso a más selección de piedras preciosas. por favor haga clic en www.presidium.com.sg



Este software no es actualmente compatible con las plataformas Mac OS.

3. LECTURA DE LOS RESULTADOS DE LA PRUEBA EN SU PRESIDUM GEM COMPUTER GAUGE

Los valores de G.E. de las siguientes piedras preciosas se almacenan en el Presidium Gem Computer Gauge:

Piedras comunes (en orden alfabético)	
Albita (feldespato)	Nefrita
Alexandrita	Obsidiana
Almandita granate	Oligoclasa (feldespato)
Ámbar	Ópalo
Andalusita	Ortoclasa
Andradita granate	Óxido de zirconio cúbico
Apatito	Perla
Azabache	Peridoto
Benitoita	Piropo granate
Berilo	Plástico
Brasilianita	Rodocrosita
Calcita	Rodonita granate
Calcedonia	Rodonita
Cianita	Rutilo sintético
Concha	Serpentina
Coral	Sinhalita
Corindón	Sodalita
Cuarzo	Titatano de estroncio
Diamante	TL grossularita granate
Danburita	Topacio
Diópsido	Turmalina
Dioptasa	TP grossularita granate
Esfena	Turquesa

Esmeralda sintética	Verdita
Espersartita granate	Vidrio
Espinel	Wernerita
Espinel sintético	Zafiro
Espodumeno	Zirconio (alto)
Fluorita	Zirconio (bajo)
GAI	Zirconio (medio)
G.G.G.	Zoisita
Hematita	
Idocrasa	
Iolita	
Jadeita	
Kornerupina	
Labradorita (feldespato)	
Lapislázuli	
Malaquita	
Marfil	
Microclina	
Moldavita	

4. CUIDADO del Presidium Gem Computer Gauge

- No deje pilas gastadas dentro del compartimiento para pilas, ya que estas pueden corroerse, tener fugas o dañar el medidor. Las pilas deberán retirarse cuando el medidor se vaya a almacenar durante un período prolongado.

El medidor es un producto de diseño y fabricación de precisión, y debe tratarse con cuidado.

Gracias por tomarse el tiempo de leer el manual del usuario que le permitirá comprender mejor su reciente compra.

Presidium también recomienda que registre su garantía enviando la tarjeta de registro de la garantía o completando el registro en línea en <http://www.presidium.com.sg/>

www.presidium.com.sg