

# GRS<sup>®</sup> Universal Positioning Pin Vise

INSTRUCTIONS • #003-775

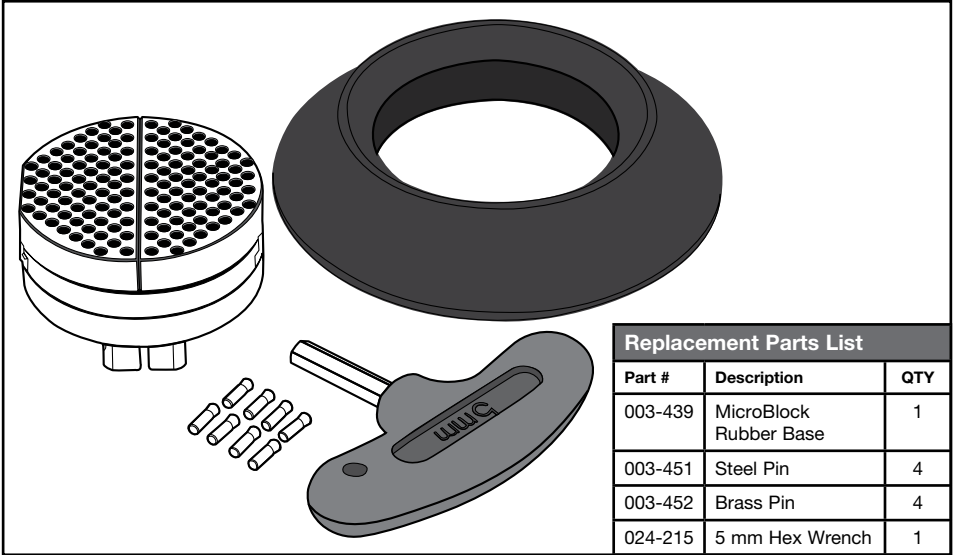

## 1. INSTALLING THE UNIVERSAL POSITIONING PIN VISE

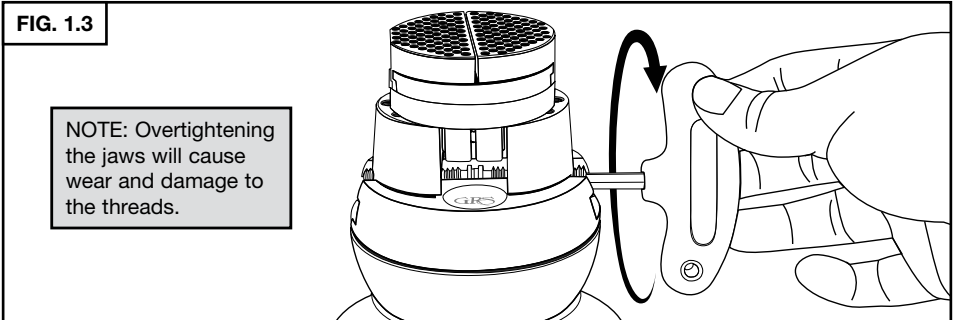
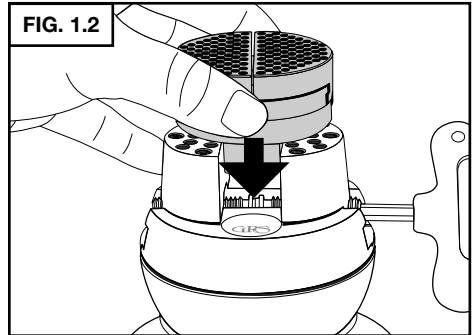
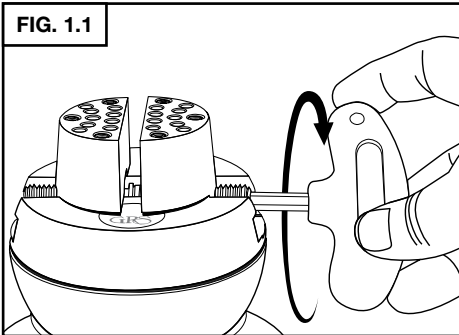

## 2. CENTERING THE THE WORK AREA

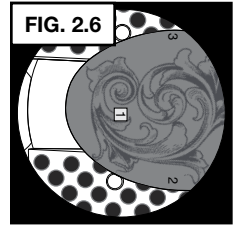
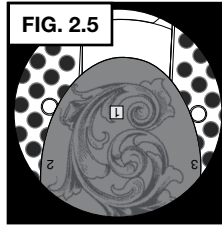
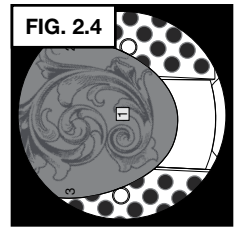
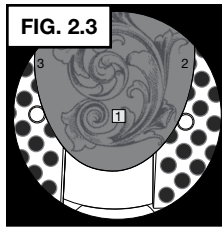
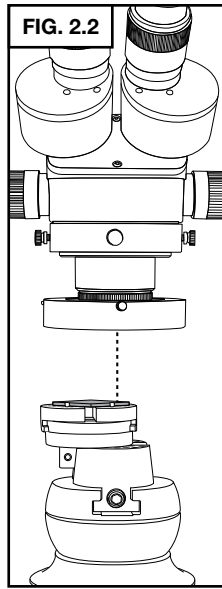
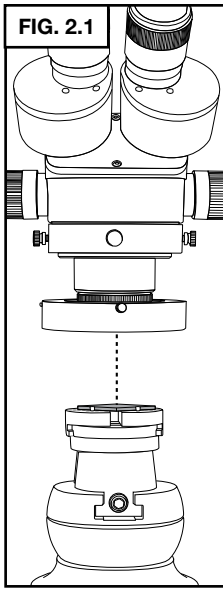

To keep your work area centered under the microscope, the Universal Positioning Pin Vise has the ability to rotate and to be moved from side to side within the jaws of the vise.

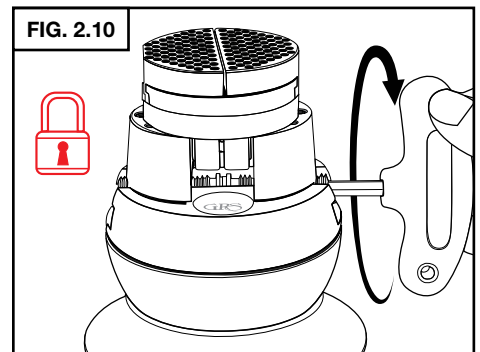
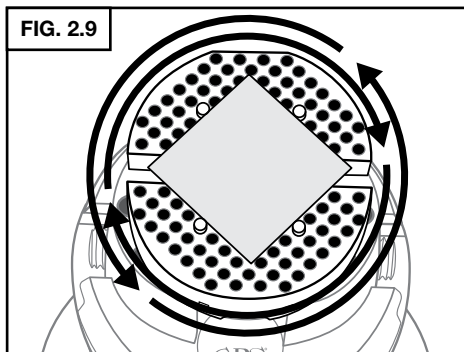
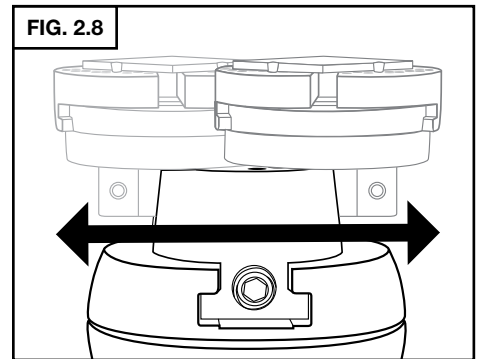
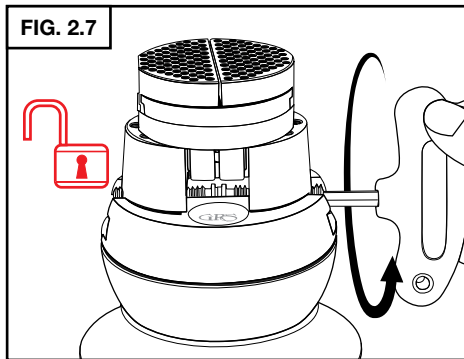

# GLEND0 LLC

900 Overlander Road • Emporia, KS 66801 USA  
800-835-3519 • 620-343-1084 • Fax: 620-343-9640  
grs@grstools.com • www.grstools.com  
Last Updated: 2018/02/09