



# Thermo-Loc®



**IMPORTANT:** When used properly, Thermo-Loc® is a versatile, safe and effective work-holding material. PROPER USE DEPENDS ON YOU. Read all instructions carefully and use this product according to instructions for your own safety.



**WARNING:** If you overheat Thermo-Loc®, you could be burned and/or release undesirable fumes. Extreme overheating could start a fire. Always heat Thermo-Loc® according to directions. Do NOT use any open flame (including a torch) to heat Thermo-Loc®. Do NOT touch Thermo-Loc® with bare hands if overheated ... let it cool first.



**MICROWAVE WARNING:** If you use a microwave oven to heat Thermo-Loc®, follow Microwave Heating Method instructions carefully. NEVER microwave Thermo-Loc® MORE THAN 20 SECONDS at a time. (If, after heating with a microwave once, you decide to heat it further, do NOT exceed 20 seconds microwave heating at a time). ALWAYS remain with your microwave oven when heating Thermo-Loc®. NEVER leave while microwave oven is operating. ALWAYS place Thermo-Loc® on a special non-stick PTFE material pad inside microwave oven. With proper procedures, microwave heating can be a fast, efficient and safe method of heating/softening Thermo-Loc® if you follow these instructions.

## Introduction to Thermo-Loc®

Thermo-Loc® is a special reusable polymer material that is rigid at room temperature yet becomes softly pliable when heated/warmed. Thermo-Loc® was developed to hold irregularly shaped or fragile items including gun parts, knives, motorcycle parts, and wood carvings for engraving, carving, finishing and other handwork. In the soft, pliable condition, Thermo-Loc® can be shaped around the item. When it cools to room temperature, Thermo-Loc® is rigid enough to hold the workpiece securely for a variety of operations. It is not an adhesive, it holds by closely fitting the workpiece itself. Thermo-Loc® can be softened in seconds in a household microwave oven, or using an electric heat gun or low temperature oven. Thermo-Loc® microwave softening capability is an important advantage for holding steel items such as gun and knife parts without the rust caused by other workholding materials that are softened in hot water.

Thermo-Loc® is supplied in convenient 6" (150mm) long sticks. The medium gray color is designed to reduce eye strain under work lights. Thermo-Loc® can be reheated and reused. It is non-toxic and biodegradable.

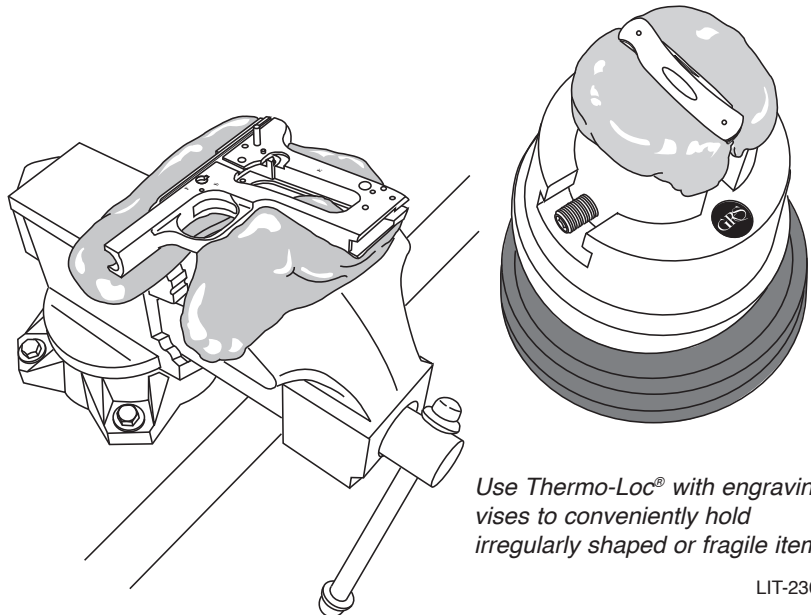

*Use Thermo-Loc® with engraving vises to conveniently hold irregularly shaped or fragile items.*

# General Instructions

When Thermo-Loc® is heated, it will soften and can stick to some surfaces. One material Thermo-Loc® will not stick to is special non-stick PTFE material. To avoid damage to counter tops and other surfaces, heat and store softened Thermo-Loc® on a PTFE pad.

NOTE: Thermo-Loc® Kit #003-667 includes a 6" (150mm) square special low friction PTFE material pad. You can also buy this pad separately as item #003-291.

When it cools, Thermo-Loc® will not stick to most metal and many other surfaces. If you are in doubt about a particular surface, first test heated Thermo-Loc® on a small hidden area. If, after cooling, the test Thermo-Loc® adheres undesirably to that surface, use a release agent (such as silicone spray) or wrap the surface with a slick material such as special non-stick PTFE tape or a piece of high-density plastic bag (like the thin, strong bags used by Wal-Mart or other stores) before applying heated Thermo-Loc® to that surface.

Thermo-Loc® has a wide variety of uses and numerous ways to use it. You can use Thermo-Loc® to cover vise jaws, pliers, clamps, tool handles and more. For many work holding applications, the workpiece can be imbedded or wrapped with Thermo-Loc® while it is warm and flexible. After cooling, Thermo-Loc® will precisely fit the workpiece contour and hold it securely. **IMPORTANT:** before you apply Thermo-Loc®, consider how you will remove the workpiece after the work is done. This planning is important since Thermo-Loc® is quite tough at room temperature. If you don't plan adequately, you could face a needlessly difficult job removing your work from Thermo-Loc®. With a little thought and experience, this should not be problem. It's a case of planning ahead. One effective technique is to use Thermo-Loc® around screw threads. After it cools, screws and bolts can be easily removed from Thermo-Loc® by simply unscrewing them.

Thermo-Loc® begins to "melt" around 145 °F (63 °C). But this "melting" is not as distinct a change as water changing from ice to liquid. By controlling how hot you heat Thermo-Loc®, you control some of its working properties. At higher temperatures, Thermo-Loc® is more flexible allowing you to work it into tighter places. And, higher temperatures give you more working time especially with large metal workpieces that quickly cool Thermo-Loc® by heat sinking. But the penalties for higher working temperatures include greater shrinkage and longer cooling time before you can work on the workpiece. At about 180 °F (82 °C), Thermo-Loc® is fairly soft and can be formed into small areas.



**IMPORTANT:** When Thermo-Loc® is heated above 180 °F (82 °C), you should use care when handling it with your bare hands to avoid burns.

# GRS® Thermo-Loc®

# HEATING INSTRUCTIONS

## Microwave Heating Method

Start with 1 or 2 Thermo-Loc® sticks. Cutting the sticks in half before heating is often more convenient than working with full length sticks. Place Thermo-Loc® material on special non-stick PTFE pad inside the microwave oven. Set oven for full power and timer for 20 seconds or less. After a maximum of 20 seconds, open microwave oven and check heated condition of Thermo-Loc®. It is likely that some parts of the Thermo-Loc® will be warmer than other parts. After you have determined that the Thermo-Loc® is not too hot to handle safely, try to fold or knead the warmed stick into a more compact shape. If you want to heat the Thermo-Loc® further, set microwave oven for a maximum of 20 additional seconds. Continue to check and reheat for 20 seconds maximum at a time until the desired temperature and pliability is reached. **NOTE:** Since microwave ovens often heat some areas more than others, move the PTFE pad around each time you open the oven. Microwave ovens vary widely in heating speed and evenness. This means it is necessary for you to experiment to determine the right combination of speed and power level for proper Thermo-Loc® warming. With a little experience, you'll soon be able to work with Thermo-Loc® safely and efficiently.

**IMPORTANT:** Always watch through the microwave window. Do NOT leave the microwave while heating Thermo-Loc®. Like most things in a microwave oven, it takes only seconds to overheat. If you overheat Thermo-Loc®, do NOT touch it with your bare hands. You could get burned. Once you work with Thermo-Loc® a few times, you will be able to tell how warm it is by its appearance and smell. Properly warmed Thermo-Loc® has only a slight plastic odor. If the odor is strong or there is discoloration or smoke, you have overheated it. Overheated Thermo-Loc® can be much more sticky than usual, so be careful when handling it.

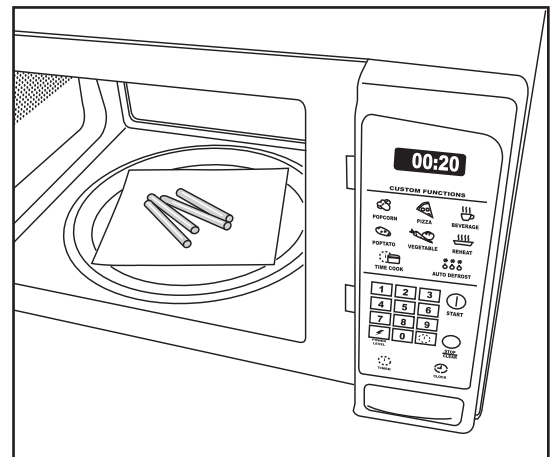

# TIPS

## Tip #1

It is important to determine that softened/heated Thermo-Loc® is safe to handle BEFORE you touch it to avoid burning your hands. As mentioned, there are some ways to do this including how it looks and smells. As Thermo-Loc® is heated, it becomes increasingly glossy in appearance and stronger in smell.

Another useful way to judge Thermo-Loc® temperature is to touch the bottom of the special non-stick PTFE pad directly under the heated Thermo-Loc® BEFORE you handle the Thermo-Loc® directly. The PTFE pad provides some protection for your hands and allows you to judge “approximately” how hot the heated Thermo-Loc® is. In this way you can get some idea of how hot the Thermo-Loc® is before touching it. As always, please be careful. ***Always let overheated Thermo-Loc® cool before you touch it!***

## Tip #2

Thin Thermo-Loc® pieces can overheat or burn more easily than thicker ones. If you are heating a piece with thin sections, heat it just enough so you can fold it into a thicker lump and then finish heating it. This will provide a more even result.

## Tip #3

If you need to make a large, thick Thermo-Loc® item, build it in layers instead of trying to work with one massive piece. By allowing each layer to cool a little before applying the next layer, you can greatly reduce the total shrinkage which can be quite beneficial. One of Thermo-Loc's useful properties is its ability to stick to itself quite well. You can add some warmed Thermo-Loc® on top of a cold piece and achieve excellent bond between the layers of Thermo-Loc®. In some applications, Thermo-Loc® shrinkage as it cools can be used to your advantage to create tight, precise holding fixtures that allow the workpiece to “snap” in and out when desired.

## Tip #4

Remember to think about how you will remove your workpiece BEFORE you form Thermo-Loc® around it. Thermo-Loc® becomes amazingly stiff at room temperature which generally prevents you from bending it out of shape to remove your part. Instead, look at the shape of your part and form Thermo-Loc® around it in such a way that it will slide off in at least one direction.

## Other Heating Methods

There are other ways to heat Thermo-Loc® such as a low-temperature slow cooker (Crock Pot), and immersing Thermo-Loc® in a hot liquid such as water. You may find some experimentation necessary to determine the best heating method for your particular work holding application. When trying various heating methods, monitor Thermo-Loc® closely and stop the heating process immediately if any signs of overheating occur. Refer to “How to Check Heated Condition of Thermo-Loc®” for more information.

## How to Check Heated Condition of Thermo-Loc®

Properly heated Thermo-Loc® will be slightly shinier than cold Thermo-Loc®. It will also start to flow or slump a little. Properly heated Thermo-Loc® will have only a slight plastic smell. While heating in a microwave oven, if you observe a noticeable or rapid swelling, STOP the oven IMMEDIATELY... a rapid rise or swelling indicates the start of overheating.

Properly heated Thermo-Loc® will be quite flexible... somewhat like modeling clay. You can control the stiffness or flexibility of Thermo-Loc® by how warm you heat it. The warmer it gets, the softer and more flexible it becomes.

Overheated Thermo-Loc® is often very shiny or even wet looking. The smell will be noticeably stronger. In extreme overheating, there can be visible smoke and a very strong smell.



**CAUTION**  
DO NOT TOUCH  
IF OVERHEATED

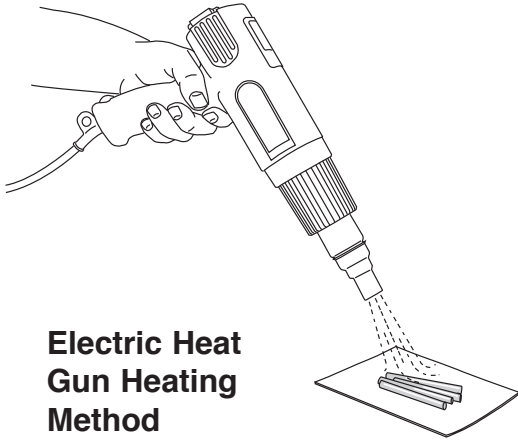

## Electric Heat Gun Heating Method

Thermo-Loc® may also be heated with an electric heat gun. Since many heat guns operate at temperatures well above that recommended for Thermo-Loc®, care and patience should be used. Keep the heat gun nozzle several inches from the Thermo-Loc® surface and move it continually to avoid overheating or burning the surface. Because a heat gun heats only the outside surface, it will take longer to thoroughly soften Thermo-Loc® with a heat gun than with a microwave oven. At times this type of exterior surface heating can be an advantage such as making slight modifications to an existing Thermo-Loc® fixture. If an electric heat gun is not available, some electric hair dryers will work but are less effective. Pay close attention to the signs of overheating including rapid surface swelling, strong plastic odor or even smoke. If any of these results, discontinue heating immediately.

## Oven Heating Method

Thermo-Loc® may be heated in a warm oven set to approximately 160-200 °F (71-93 °C). When using an oven, place Thermo-Loc® on a special non-stick PTFE pad on top of a cookie sheet. Let the oven slowly warm the Thermo-Loc®. Remove carefully and be sure the heated Thermo-Loc® is not too hot for you to handle safely. Do NOT try to rapidly heat Thermo-Loc® by using elevated oven temperatures. This could cause overheating including strong fumes, smoke and dangerously hot Thermo-Loc® that could burn you when touched.

# GRS<sup>®</sup> Thermo-Loc<sup>®</sup>

## Special Fixtures

### Thermo-Loc<sup>®</sup> Starter Kit:

**#003-667** Includes 6" (150mm) square special non-stick PTFE pad and 1 lb. (450 gm) Thermo-Loc<sup>®</sup> sticks.

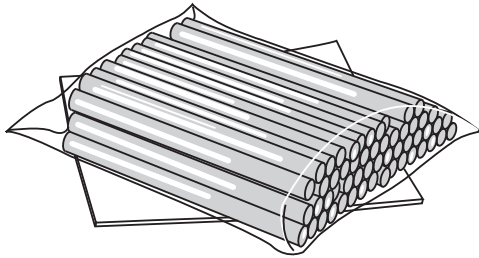

### Thermo-Loc<sup>®</sup> sticks with instructions

**#003-664** 0.5 lb. (225 gm)

**#003-665** 1.0 lb. (450 gm)

**#003-666** 5.0 lb. (2.26 kg)

### Special non-stick PTFE pad

**# 003-291** 6" (150mm) square special non-stick PTFE pad

*Included with Thermo-Loc<sup>®</sup> Starter Kit #003-667 above.*

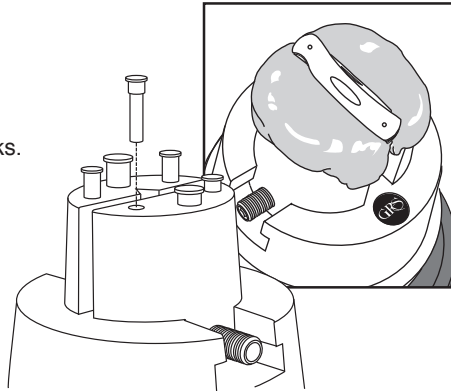

Glendo offers fixtures and accessories designed especially for using Thermo-Loc<sup>®</sup> with GRS<sup>®</sup> Engraving Vises. This includes a Thermo-Loc<sup>®</sup> Pin Kit which is a set of stainless steel pins that fit into the top jaw holes of GRS<sup>®</sup> vises (engraving blocks). Softened Thermo-Loc<sup>®</sup> can be applied around these pins and formed to fit the workpiece. After cooling, the formed Thermo-Loc<sup>®</sup> with imbedded pins can be removed from the jaws and reinstalled when desired. The stainless steel pins provide better clamping than using Thermo-Loc<sup>®</sup> alone.

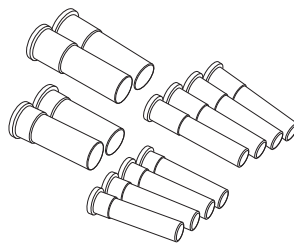

### Pin Kit for GRS<sup>®</sup> Magnablock Vise:

**#003-671** Includes 4 ea. 1/4" short pins, 4 each 1/4" medium pins, 2 each 3/8" short pins, 2 each 3/8" medium pins; this kit also fits GRS<sup>®</sup> Positioning Vise and GRS<sup>®</sup> Low Profile Vise.

### Pin Kit for GRS<sup>®</sup> Standard Vise:

**#003-670** Includes 6 ea. 1/4" short pins, 6 each 1/4" medium pins.

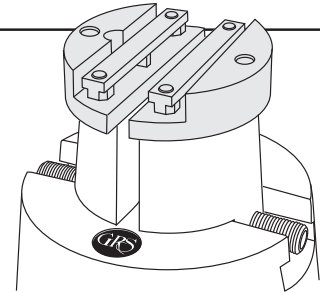

Another fixturing aid is the Thermo-Loc<sup>®</sup> Jaw Kit. This kit includes machined stainless steel upper plates that fit onto GRS<sup>®</sup> engraving vise jaws. Then, a mating metal bonding strip is bolted onto each upper plate. Finally, softened Thermo-Loc<sup>®</sup> is formed onto the upper plate and around the bonding strip to hold the desired workpiece. After cooling, the imbedded bonding strips with attached Thermo-Loc<sup>®</sup> can be unscrewed and removed. This gives you the option to save and remount these formed Thermo-Loc<sup>®</sup> holders for future jobs on the same type of workpiece.

### Thermo-Loc<sup>®</sup> Jaw Kit for GRS<sup>®</sup> Magnablock Vise:

**#003-669** Includes 2 master upper jaws (one pivoting), 4 threaded bonding strips, bolts and wrench; this jaw kit also fits GRS<sup>®</sup> Positioning Vise and GRS<sup>®</sup> Low Profile Vise.

### Thermo-Loc<sup>®</sup> Jaw Kit for GRS<sup>®</sup> Standard Vise:

**#003-668** Includes 2 master upper jaws (one pivoting), 4 threaded bonding strips, bolts and wrench. This jaw kit fits only GRS<sup>®</sup> Standard

Engraving Vises which are smaller than GRS<sup>®</sup> Magnablock-type vises

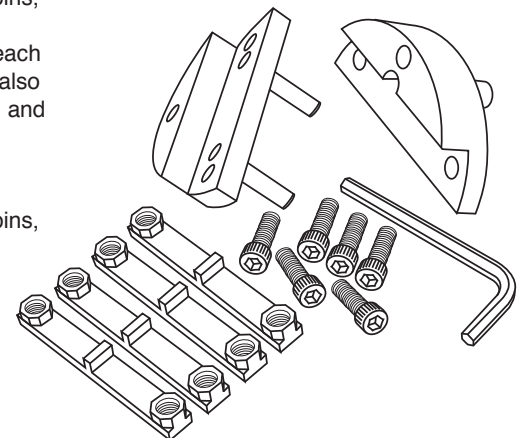

## GLENDO LLC

900 Overlander Road • Emporia, KS 66801 USA  
800-835-3519 • 620-343-1084 • Fax: 620-343-9640  
grs@grstools.com • www.grstools.com  
Last Updated: 2015-12-02

Thermo-Loc is a trademark of Glendo LLC.  
Printed in the USA  
All rights reserved. © 2004 Glendo LLC