

### Specification

11 ½"

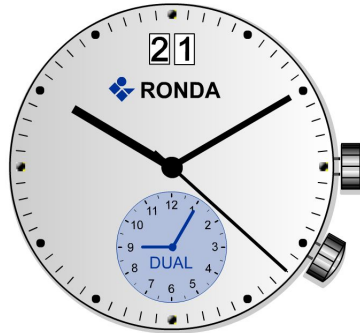

#### Dimensions and battery

∅ Total	26.2 mm
∅ Case fitting	25.6 mm
Movement height	3.30 mm
Movement rest	1.40 mm
Height of stem	1.80 mm
Stem: Thread / Distance	0.90 mm / 0.90 mm
Battery / Autonomy	Nr. 373 / 36 Months

#### Performances

	Second hand: 6 µNm
Torque T	Minute hand: 300 µNm
Operating temperature	0°C - 50°C
Res. against magn. fields	18.8 Oe = 1500 A/m
Resistance against shock	NIHS 91 - 10

#### Functions

Position I (crown)	Neutral
Position II (crown)	Setting the date (quick mode)
Position III (crown)	Setting Time
Position I (crown 2)	Neutral
Position II (crown 2)	Set 2nd time

### Assembling

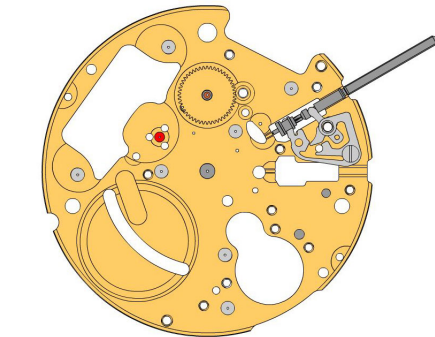



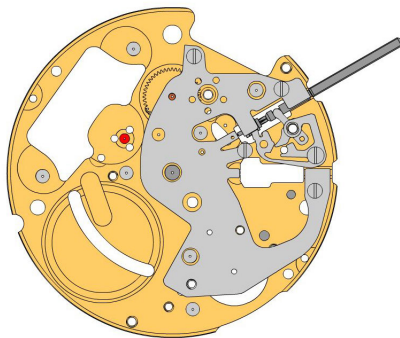



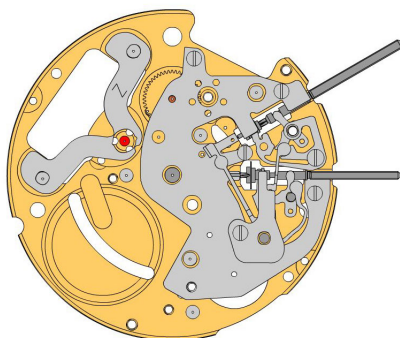









A



B



C

1. **2000.625.G** Main plate  

2. **3017.052** Setting lever  
The cam on the setting lever must be inserted into the cut out on the stem. (the setting lever must be greaced)  

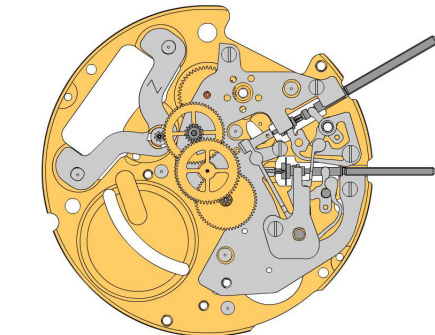
3. **3015.075** Yoke dual  
Use 1 screw 4000.282  

4. **4000.282** Screw  

5. **3001.044** Sliding pinion  
The sliding pinion must be holded using a tweezers, untill the stem is inserted.  

6. **3000.190.CO** Handsetting stem  
Prior to the insertion of the stem, some greace must be placed on the square part of the stem.  

7. **3301.277** Hour wheel dual BD  

8. **2130.167** Centre bridge  
Use 4 screws 4000.300 to fix the center bridge.  

9. **4000.300** Screw  

10. **3017.052** Setting lever  
The cam on the setting lever must be inserted into the cut out on the stem. (the setting lever must be greaced)  

11. **3015.074** Yoke (3 positions)  
The yoke must be inserted below, into the cut out of the sliding pinion.  

12. **3001.042** Sliding pinion  
The sliding ponion must be holded using a tweezers, untill the stem is inserted.  

13. **3000.189.CO** Handsetting stem  
Prior to the insertion of the stem, some greace must be placed on the square part of the stem.  

14. **2020.166** Yoke bridge  
Use 1 screw 4000.244.  

15. **4000.244** Screw  

16. **3622.042** Stator  

### Assembling



D

17. **3715.103.RK** Rotor centre  
 \*  Use an antimagnetic tweezers to place the rotor.

18. **3147.056.CO** Intermediate wheel  
 →

19. **3122.059.CO** Third wheel  
 →

20. **3136.160.CO** Second wheel (height 1)  
 ↓

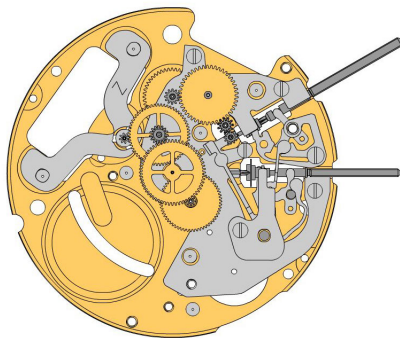

E

21. **3305.313** Pignon chausée dual  
 \*  ↑

22. **3004.185.CO** Setting wheel inter. dual  
 \* 

23. **3004.198.FI** Setting wheel dual  
 \* 

24. **3007.074.CO** Minute wheel dual  
 →

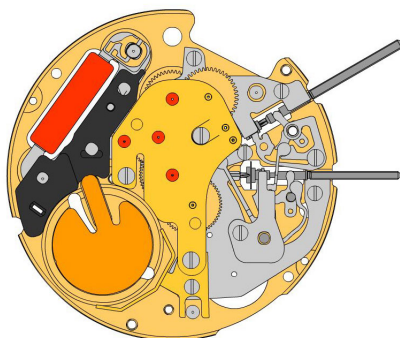

F

25. **2020.167.G** Train wheel bridge  
 Attention: Prior to the fastening process of the bridge, all pins of the wheels must be visible in the holes in the bridge. Use 3 screws 4000.279.

26. **4000.279** Screw  

27. **3601.117** Battery contact spring  
 Use 1 screw 4000.244.

28. **4000.244** Screw  

29. **3621.060.RK** Coil (movment)  
 The wire of the coil (red area) is very sensitiv to mechanical impacts. Hold the coil only outside the red area. Fix the coil by 1screw 4000.250.

30. **3603.074** Bride insulator  

31. **3603.075** Battery insulator  

### Assembling

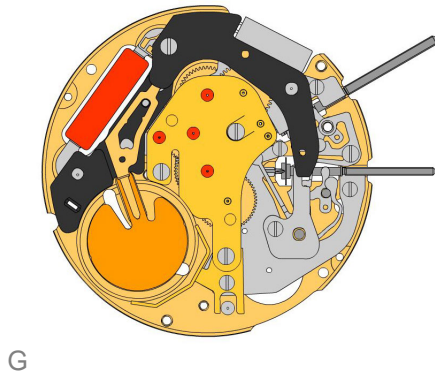

32. **3601.116** **Bridge (-)**  
 Make shure, that the pusher contact spring is placed correctly onto the pillars.

33. **3612.181.6203** **Electronic module**  
 After assembly of the electronic module it is the best time to perform the electrical measurements. Use 1 screw 4000.318 to fix the electronic module.

34. **4000.318** **Screw**

35. **2130.168.6203.B** **Electronic module cover (counter 6h)**  
 Use 3 screws 4000.102 to fix the electronic module cover

36. **4000.102** **Screw**

37. **3600.031** **Battery**  
 Use a plastic tweezers to place the battery (to avoid short circuit of battery).

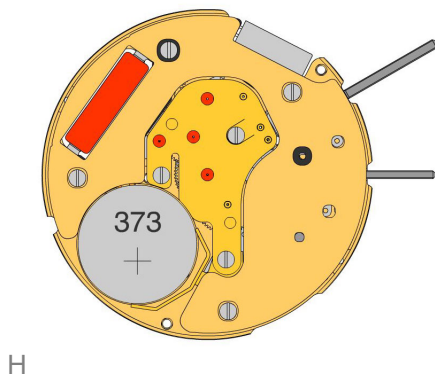

### Assembling

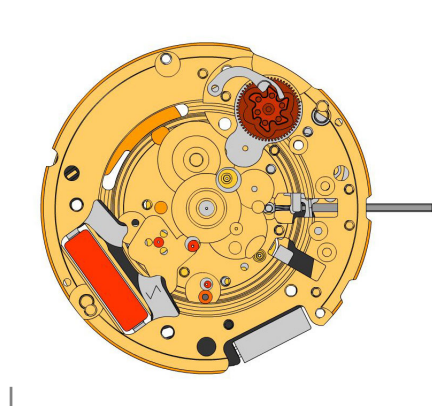

38. 2000.625.Gb Main plate



39. 9014.000 Moebius 9014  
 Use Moebius 9014 on bearing of all rubis



40. 3004.188 Tens indicator driving wheel  
 The short tooth of the tens indicator driving wheel must point to the center of the movement.



41. 3500.060 Tens jumper  
 Moebius 8200 grease must be placed between the tens jumper and the tens indicator driving wheel.



42. 2130.171 Tens jumper maintaining plate  
 Make shure, that the tens indicator driving wheel is not blocked prior to the fastening process. Use 2 screws 4010.306. Place the spring loaded bracket outside of the tens jumper.



43. 4010.306 Screw



44. 3004.182 Setting wheel  
 Use Moebius 9020



45. 3004.183 Setting wheel inter.



46. 3305.305.CO Date indicator driving wheel  
 Moebius 9020 must be used in the center of this wheel

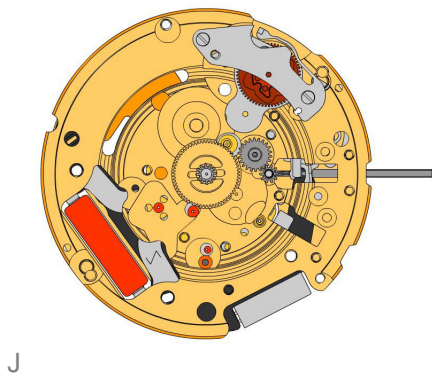

47. 3007.073



48. 3301.271.CO Hour wheel (Aig 1)



49. 3315.001 Hour wheel friction spring



50. 3004.187 Date indicator driving wheel  
 Moebius 9020 must be used in the center of this wheel.



51. 3500.061 Date jumper  
 Moebius 8200 grease must be placed between the date jumper and the date jumper spring

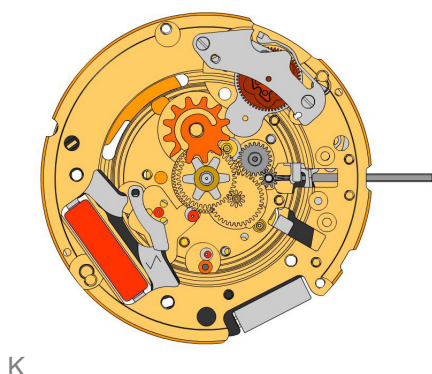



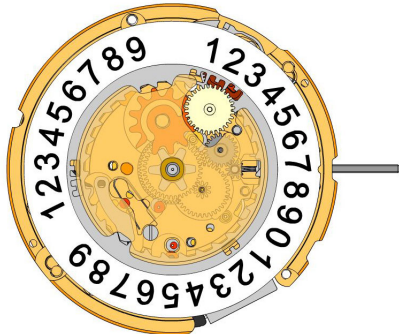



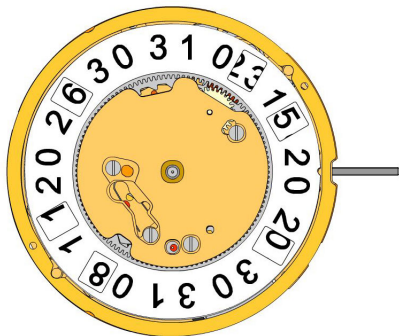



### Assembling



L



M

- 52. 3504.217 **Units indicator**  
 Teeth must be greaced using Moebius 8200. The "half moon" cut out on the unit indicator must point to the stem (position 3h).  

- 53. 3147.057 **Tens intermediate wheel**  

- 54. 2130.169 **Date indicator maintaining plate**  
 use 1 screw 4000.312  

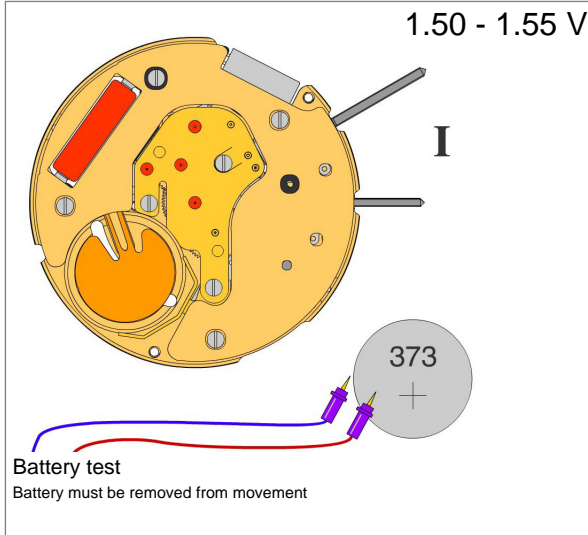
- 55. 3905.050 **Date jumper spring**  
 Insert the spring into the opening of the date indicator maintaining plate  

- 56. 3504.218 **Tens indicator (T3/G12)**  
 The "half moon" cut out on the tens indicator must point to the stem (position 3h).  

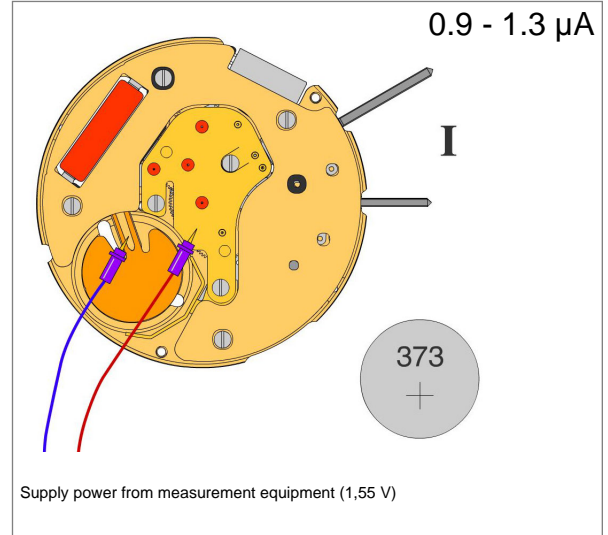
- 57. 2130.170 **Date mechanism maintaining plate**  
 Assure that the tens intermediate wheel is not blocked, prior to the fastening process. Use 3 screws 4000.312 to fix the date indicator maintaining plate.  

- 58. 4000.312 **Screw**  

- 59. 3506.075.G **Dial support**  

- 60. 9010.000 **Moebius 8200**  
 Microgliss D5 can be used  

- 61. 9018.000 **Jismaa 124**  
 Greace Moebius or Microgliss D5 an be used  

- 62. 9020.000 **Moebius 9020**  

### Electrical checking

#### Voltage of battery



#### Consumption of movem. (Pos. I)



#### Consumption of movem. (Pos. III)

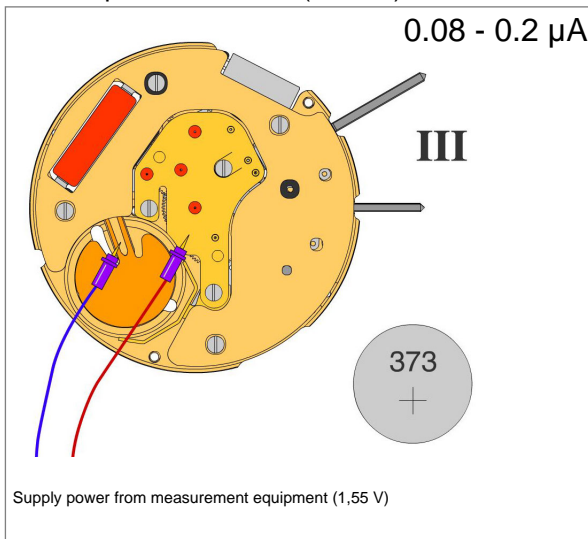

#### Lowest voltage for movement

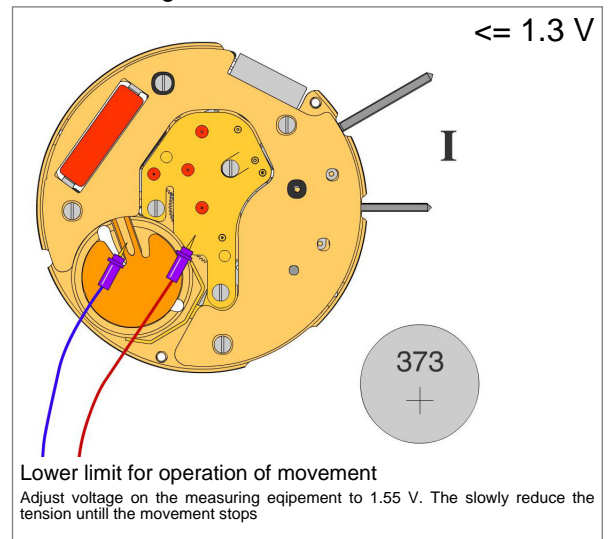

#### Accuracy (seconds / month)

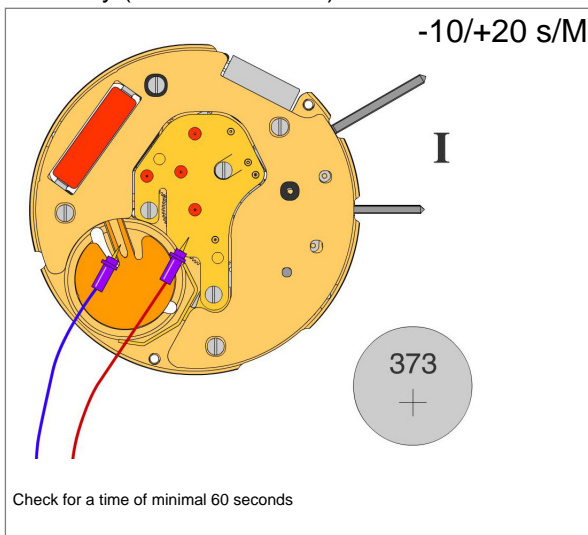

#### Resistance of the coil

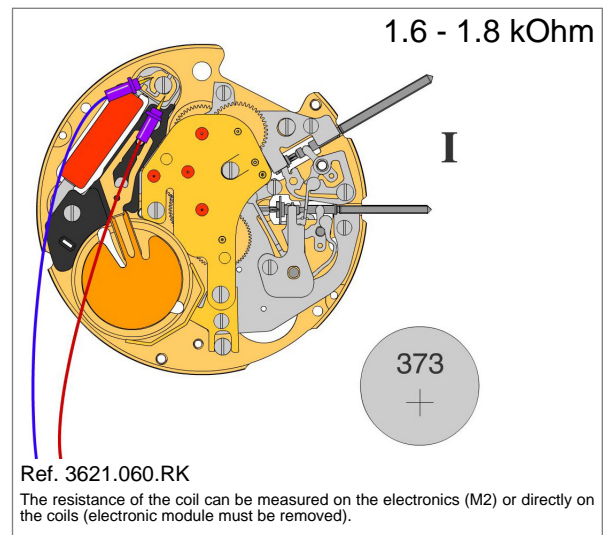

### Electrical checking

#### Coil insulation

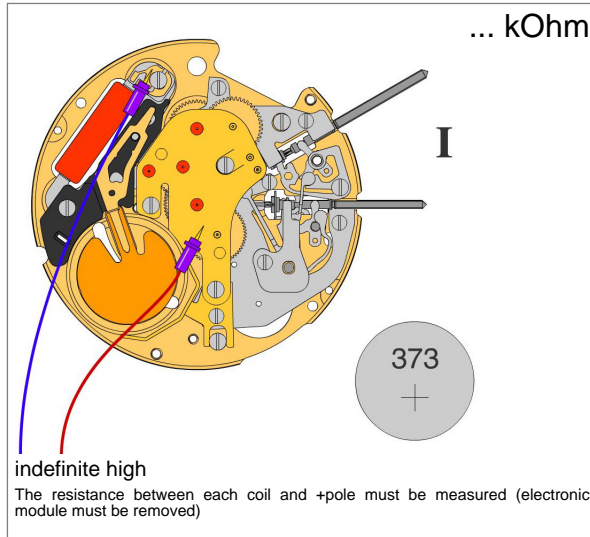

#### Accelerated test of movement

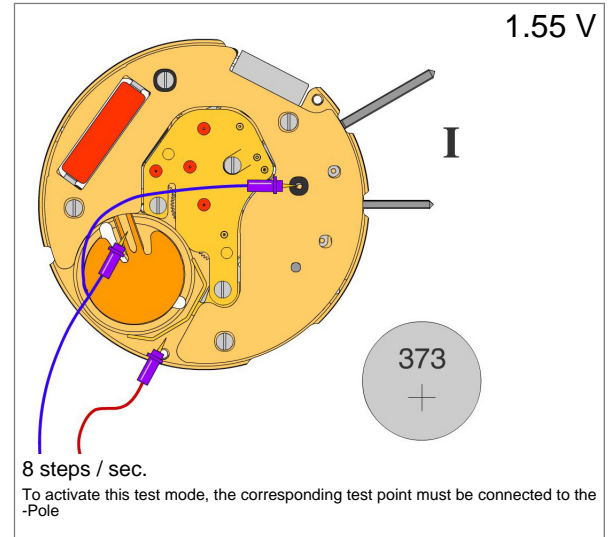

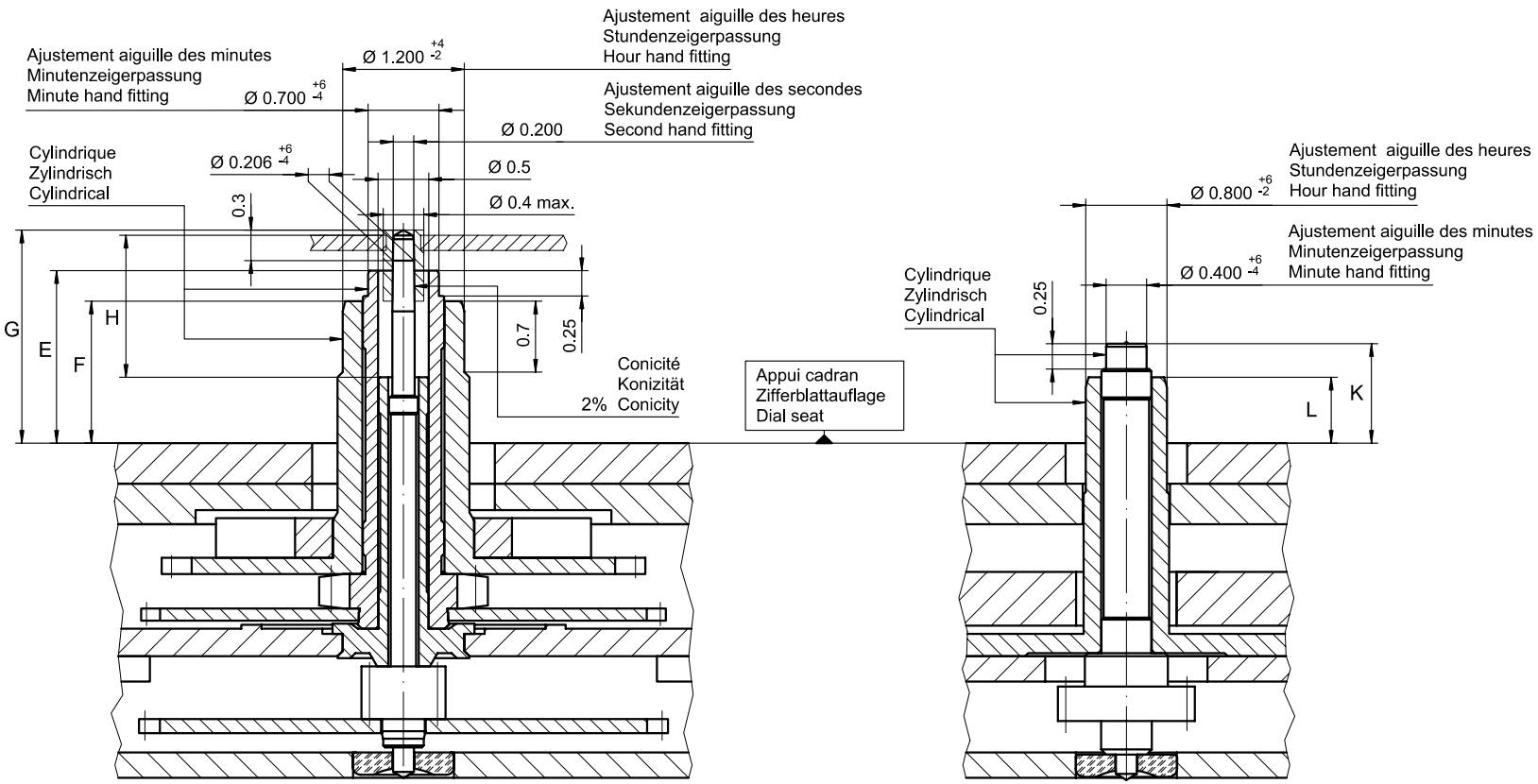

Heures / minutes / secondes  
Stunden / Minuten / Sekunden  
Hours / minutes / seconds

Dual  
Dual  
Dual

Aiguillages Zeigerwerkhöhe Hand fitting height		Dépassement Höhe über Zifferblattauflage Height over dial seat				
No	Pignon des secondes Sekundentrieb Second pinion	Chaussée Minutenrohr Cannon-pinion	Roue des heures Stundenrad Hour wheel	Dual		
				Chaussée Minutenrohr Cannon-pinion	Roue des heures Stundenrad Hour wheel	
	G	E	F	H	K	L
1	2.10	1.70	1.40	1.45	0.98	0.65
2	2.30	1.90	1.60	1.65	1.18	0.88

Aiguillages Zeigerwerkhöhe Hand fitting height		Peinture comprise / inkl. Farbe / Paint included				
No	Sous l'aiguille des secondes Unter Sekundenziger Under second hand	Sous l'aiguille des minutes Unter Minutenzeiger Under minute hand	Sous l'aiguille des heures Unter Stundenzeiger Under hour hand	Dual		
				Sous l'aiguille des minutes Unter Minutenzeiger Under minute hand	Sous l'aiguille des heures Unter Stundenzeiger Under hour hand	
Epaisseur maximum du cadran Maximale Zifferblattstärke Maximum dial thickness						
					Epaisseur des aiguilles Zeigerdicke Hands thickness	
1	1.60	1.30	1.00	0.55	0.25	0.15
2	1.85	1.50	1.20	0.75	0.45	0.15

	Aig. des secondes Sekundenziger Second hand	Aig. des minutes Minutenzeiger Minute hand	Aig. des heures Stundenzeiger Hour hand	Dual		Lors de la pose d'aiguilles, le mouvement doit être soutenu. Beim Zeigersetzen muss das Werk abgestützt werden. The movement needs to be supported for hand setting.
			Aig. des minutes Minutenzeiger Minute hand	Aig. des heures Stundenzeiger Hour hand		
mg max.	10	30	30	10	10	Masse / Masse / Weight *
µNm max.	0.05	0.60	0.60	0.15	0.15	Balourd / Unwucht / Unbalance *
gmm <sup>2</sup> max.	0.7	-	-	-	-	Inertie / Massenträgheit / Inertia *
N max.	30	40	40	30	30	Force de chassage / Aufpresskraft / Force

Sous réserve de toutes modifications

Aenderungen vorbehalten

All modifications reserved

Aiguillages Zeigerwerkhöhen Hand fitting heights		Issued	05 sep 2005	fl	
<h1>11½"</h1>		Modified	02.08.2010	dh	
		Released	Yes		
		Tolerance	µm		
		Scale	20 : 1 (A3H)		
RONDA 6203.B		Sous réserve de modifications Aenderungen vorbehalten Modifications reserved			
		No.	3316.100	06	

\* En cas de données différentes, veuillez contacter le service après-vente

\* Bei abweichenden Werten, bitte technischen Kundendienst anfragen

\* In case of different values, please contact the customer service