

INSTRUCTIONS

Description des éléments :

MSA

01.504-4.3	A Screwdriver holder, handle ø 4.30 mm
01.504-4.8	B Screwdriver holder, handle ø 4.80 mm
01.504-5.3	C Screwdriver holder, handle ø 5.30 mm
01.502-A	P1 Interchangeable round stone
01.502-B	P2 Interchangeable square stone
01.502-V	V1-V2-V3 Assortment of 5 screws [2x V1, 1x V2 and 2x V3]

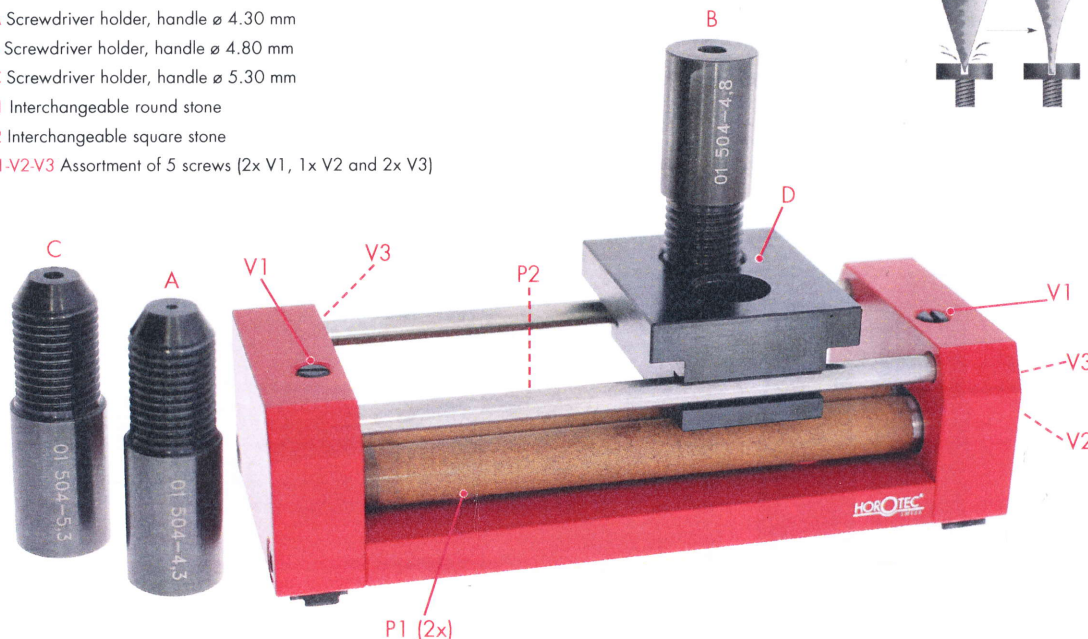
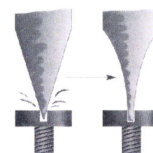

FUNCTION

This HOROTEC® tool for screwdriver blades round sharpening. Using this tool avoids any damage of screws angles when repairing or assembling watches. These so sharpened screwdrivers will be mainly used for repairing of high range watches with crystal case backs showing the movements and provided with gold or blued screws.

INSTRUCTIONS OF USE

1) ADJUSTMENT OF THE ROUND STONES GAP

Adjust the gap between both round stones P1 using the 2 screws V1.

The adjustment of the gap between the stones will be done according to blade diameter.

Reverse the tool to adjust the parallelism of the 2 round stones through the 2 drillings of each side of the base.

2) INTRODUCTION OF THE SCREWDRIVER IN ONE OF THE APPROPRIATE SCREWDRIVER HOLDER

Insert a screwdriver in one of the screwdriver holder A/B/C according to the diameter of the screwdriver handle.

3) BLADE ROUND SHARPENING

Introduce both screwdriver and holder in the bore of the sliding table D corresponding to the round stones.

Position the screwdriver blade so its thread is parallel to the 2 stones.

The blade round sharpening will be done by moving the sliding table + screwdriver holder + screwdriver from right to left and left to right, to give to the blade the desired round sharpening. For this operation, just put the index finger on the screwdriver head to hold it.

For a more efficient sharpening, oil the stones.

4) BLADE DEBURRING

Burrs will be formed on the base of the blade during round sharpening.

To remove these burrs, just move the screwdriver holder + screwdriver into the other bore of the sliding table.

Proceed with a movement from right to left and left to right with the base of the blade touching the square stone P2.

5) MAINTENANCE AND REPLACEMENT OF THE STONES

For a more efficient sharpening, oil the stones. To keep the round shape of both stones P1 as long as possible, turn them regularly.

For this, unscrew the 2 screws V3 maintaining the stones by springs.

The replacement of the round stones is done by completely unscrewing the screws V1 and V3 to release the springs tension.

The replacement of the square stone P2 is done by slightly unscrewing the screw V2.

DIMENSIONS : 130 x 50 x 45 mm

WEIGHT : 0.530 Kg



Swiss Market

T +41 32 925 95 95
F +41 32 925 95 96
E swiss@horotec.ch

HOROTEC SA

Av. Léopold-Robert 105b
2300 La Chaux-de-Fonds
Switzerland | www.horotec.ch

Export Markets

T +41 32 911 21 21
F +41 32 911 21 22
E export@horotec.ch

