



## Operating manual



**Elmasolvex®VA**

**Watches / small parts cleaning unit**

• english •

## Contents

1	General.....	5
2	Important safety instructions.....	5
2.1	Notes for using this manual.....	5
2.1.1	Information signs / symbols in the manual / on the unit.....	5
2.1.2	Signal words in this manual .....	6
2.2	Safety instructions for use of the unit .....	6
3	Product description.....	8
3.1	How it Works.....	8
3.2	Product Features .....	9
3.3	Scope of delivery .....	10
3.4	Optional accessories.....	10
3.5	CE conformity .....	11
3.6	Technical Data.....	12
3.7	Unit front side description.....	13
3.8	Unit rear side description .....	14
3.9	Control panel description .....	15
3.10	Handling of the control panel .....	15
3.11	Description of the navigation symbols.....	16
3.12	Cleaning chamber description.....	17
3.13	Media tanks description .....	18
3.13.1	Suction filter functionality .....	18
4	Before the initial commissioning .....	19
4.1	Unpacking and installing the cleaning unit .....	19
4.2	Attaching protective grilles .....	20
4.3	Connecting activated carbon unit or exhaust air tubes .....	21
4.4	Filling media tank.....	23
4.4.1	Checking shut-off valves of the quick couplings...26	
5	Initial commissioning .....	28
5.1	Connecting cleaning unit to mains power supply.....28	
5.2	Switching on cleaning unit.....28	
5.3	Selecting language in the display .....	28
6	Daily cleaning operation .....	29
6.1	Checking filling levels of the media tanks.....29	
6.2	Loading and inserting cleaning basket .....	30
6.3	Selecting and starting cleaning program .....	33
6.3.1	Special Programs .....	37
6.4	Interrupting / aborting cleaning program.....38	

7	Settings .....	40
7.1	Unit Settings .....	40
7.1.1	Date / Time .....	41
7.1.2	Administrator PIN.....	42
7.1.3	Event List.....	44
7.1.4	Changing user language.....	46
7.1.5	Visible cleaning programs.....	47
7.1.6	Reminders .....	48
7.1.7	Display Operating Hours.....	54
7.1.8	Setting signal tone for program end .....	55
7.2	Creating your own cleaning programs.....	56
7.2.1	Create new cleaning program.....	57
7.2.2	Create cleaning program from copy .....	59
7.2.3	Modifying existing cleaning program.....	61
7.2.4	Delete cleaning program.....	62
8	Media (cleaning / rinsing solutions) .....	63
8.1	Recommended media .....	64
8.2	Technical limitations.....	65
8.3	Limitations for solvent-based media.....	65
8.3.1	Flammable, solvent-based media .....	65
8.3.2	Non-flammable, solvent-based media.....	65
8.3.3	Environmental hazard from solvent-based media .....	66
9	Care and maintenance tasks .....	67
9.1	Daily maintenance actions .....	67
9.1.1	Filling level check of the media tanks.....	67
9.1.2	Cleaning the cleaning chamber.....	68
9.1.3	Cleaning of the drain sieve .....	68
9.1.4	Cleaning the filling level sensors.....	68
9.1.5	Leak checks.....	69
9.2	Continuous maintenance actions .....	70
9.2.1	Change of cleaning and rinsing media .....	70
9.2.2	Inspect media tanks, covers, suction filters .....	71
9.2.3	Cleaning basket.....	73
10	Maintenance actions / service intervals .....	75
10.1	2-5 years service interval by user.....	75
10.1.1	Replace seal for cleaning chamber cover .....	76
10.2	5 years service interval by Service Centre .....	77
10.2.1	Prescribed parts to be replaced (mandatory) .....	77
10.2.2	Recommended parts to be replaced .....	78
10.3	Service intervals according to display message .....	80
10.3.1	Replace seal of the basket rotation unit .....	80

---

10.4	Extended safety test .....	82
11	Operating faults .....	84
11.1	Fault messages on the display.....	84
11.2	Unit faults without indication on the display .....	94
11.3	Fault clearance by user.....	94
11.3.1	Cleaning deflagration protection .....	95
11.3.2	Manual venting of the cleaning chamber.....	97
11.4	Repairs .....	98
12	Decommissioning and disposal .....	99
13	Manufacturer address / contact address .....	99
14	Appendix 1: Activated carbon unit .....	100
14.1	Description.....	100
14.2	Filling / Installation / Commissioning .....	102
14.3	Maintenance .....	103
14.3.1	Emptying condensate separator .....	104
14.3.2	Replacing activated carbon granulate .....	104
14.3.3	Changing PE filter.....	105
15	Appendix 2: Pager .....	107

# 1 General

The present Operating Instructions are part of the delivered equipment. They must be ready for use at any time and remain with the unit in case of resale. We reserve the right to carry out technical modifications on the unit due to advanced development. An operating manual cannot take account of every conceivable use. An operating manual cannot take account of every possible use. Contact your dealer or the manufacturer for further information or in the event of problems which are not covered or not sufficiently covered in this operating manual.

# 2 Important safety instructions

## Strictly observe the following before start-up

Read through this manual carefully before use and only use this cleaning unit in accordance with the instructions included here. In addition to the instructions in this operating manual, also observe the country-specific safety regulations.

## Exclusion of liability

The manufacturer shall not accept any liability in the event of injuries to persons, damage to the cleaning unit or product to be cleaned which has been caused by improper use contrary to the instructions in this operating manual and non-observance of the maintenance intervals.

The owner shall be responsible for the instruction of the operating personnel.

## 2.1 Notes for using this manual

### 2.1.1 Information signs / symbols in the manual / on the unit



This symbol warns about the risk of injury from electricity.



This symbol warns about the risk of injury from flammable substances.



This symbol warns that a potentially explosive atmosphere can occur in the indicated area.



This symbol warns about injuries from hot surfaces and liquids.



This symbol provides a general warning about the risk of injury.



This symbol prohibits the use of any kind of ignition source in this area.



This symbol indicates the check of the quick coupling connections (correct seating, shut-off valves).



This symbol indicates a risk of property damage.



This symbol indicates supplementary information.

## 2.1.2 Signal words in this manual

<b>Danger</b>	The "danger" signal word warns about severe injuries with risk of fatal injury.
<b>Warning</b>	The "warning" signal word warns about severe injuries.
<b>Caution</b>	The "caution" signal word warns about slight to medium injuries.
<b>Attention</b>	The "attention" signal word warns about property damage.

## 2.2 Safety instructions for use of the unit

First, strictly make yourself familiar with the safety instructions before start-up.

A summary of the safety instructions can be found here. These are shown again in this operating manual before the respective handling instructions.

<b>Intended use</b>	This watch cleaning unit is exclusively intended for cleaning mechanical precision parts such as dismantled and not dismantled watch movements using solvent-based cleaning and rinsing media (see <i>Chapter 8</i> ).  Flammable liquids can be used as cleaning and rinsing media when used as intended. However, it is not permitted to operate the unit in an environment with potentially explosive atmosphere of gases, fumes or dusts.
<b>User</b>	The unit must only be operated by trained personnel in accordance with this operating manual.
<b>Handling of the machine</b>	Due to its weight the machine must be handled by 2 persons!
<b>Inspection for damage</b>	Examine the unit and mains power cable for transport damage. Do not start up the unit in the event of detected damage.
<b>Mains power connection</b>	For safety reasons, the unit must only be connected to a grounded socket in accordance with the regulations. The technical details of the rating plate must match the available connection conditions, particularly mains voltage and connected load.
<b>Prevention of electrical accidents</b>	Keep the installation area, case and controls dry. Protect against ingress of moisture. Unplug the mains plug during filling, maintenance and care of the unit, suspicion that liquid has penetrated, operating faults and after use.  The unit must only be opened by qualified electricians.
<b>Installation</b>	The unit must be installed at a dry and sufficiently ventilated place for the extraction of vapours of the cleaning and rinsing media from the area of the media tanks filled with these media. The installation surface must be smooth and flat for application-related reasons.

<b>Ambient temperature</b>	The maximum permitted ambient temperature is 30 °C.
<b>Exhaust air equipment</b>	The intended exhaust air equipment (exhaust air pipes with maximum length 5 m or activated carbon unit) for them must be installed at the ventilation openings (unit rear side) before start-up.
<b>Media (cleaning / rinsing solutions)</b>	<p>Only permitted media must be used in this unit. Observe the information in <i>Chapter 8</i>.</p> <p>The unit is only permitted to be operated with the connected and correctly filled 4 original media tanks included in the scope of delivery (see <i>Chapter 4.4</i>).</p>
<b>Fire and explosion hazard</b>	<p>Ignitable solvent vapours can escape in the case of improper operation (without exhaust air connection) and during replacement of the cleaning and rinsing media.</p> <p>Smoking and open ignition sources in the unit surroundings, particularly in the immediate vicinity of the zone marked with the appropriate danger symbol are therefore prohibited.</p> <p>Strictly observe the safety instructions specified in this manual to prevent such hazards.</p> <p>In the event of liquid discharge from the cleaning unit (amount &gt; droplets), the unit must no longer be operated for safety reasons.</p> <p>Maximum one day's requirement of the solvents used is permitted to be stored in the surroundings of the cleaning unit at a minimum distance of 3 m from the cleaning unit.</p>
<b>Hazards from solvents</b>	Observe the specified safety measures in the safety data sheets of the respective media used. This also applies with respect to solvent vapours.
<b>Hot surfaces</b>	Depending on the operating time of the cleaning unit, surfaces, particularly the inner wall of the drying chamber, can become very hot (max. approx. 65 °C).
<b>Cleaning basket</b>	<p>Only the Elma cleaning basket or Elma plate holder is permitted to be used to prevent damage to the cleaning chamber and product to be cleaned.</p> <p>The maximum load weight of the cleaning basket with cleaning parts is 100 grams.</p> <p>Ensure even balanced loading of the cleaning basket for fast rotations around the axis of the cleaning basket.</p> <p>Pay attention when inserting the cleaning basket that it is attached correctly (ball pressure protection engaged).</p> <p>Reduce the spinning speed in the case of critical loading.</p>
<b>Opening cleaning chamber</b>	<p>The cleaning chamber must not be opened during operation.</p> <p>Solvents can spray out!</p> <p>Fast rotating cleaning basket!</p>

### 3 Product description

The Elmasolvex®VA is a completely automatic cleaning unit for cleaning mechanical precision parts.

With innovative product characteristics, the Elmasolvex®VA cleaning unit provides a high standard of cleanliness with certified compliance with the EU regulations for unit and explosion safety for cleaning with flammable solvents (see Declaration of conformity, *Chapter 3.5*).

#### 3.1 How it Works

The cleaning and rinsing media are drawn into the cleaning chamber one after the other using a vacuum from the media tanks in the bottom part of the cleaning unit.

The cleaning is then performed under vacuum conditions with multiple frequency ultrasound technology using rotation or oscillation. There are different previously programmed standard programs and cleaning programs freely programmable by the user available for the microprocessor-controlled cleaning process.

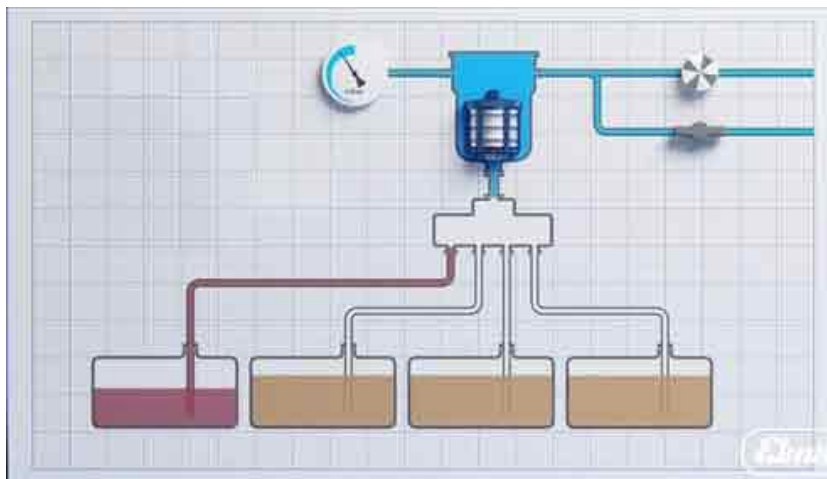

Fig. 3.1.1 Schematic diagram of the functional principle





Fig. 3.1.2 View of cleaning basket in cleaning chamber

## 3.2

### Product Features

- Safe TÜV-certified solvent-based, water-free 4-stage cleaning and rinsing, also with flammable solvents in accordance with the applicable EU safety regulations, certified by TÜV Rheinland.
- Cleaning with vacuum technology below 130 mbar absolute also enables access of the cleaning and rinsing media to otherwise not accessible or inadequately accessible areas of geometrically complicated parts.
- Cleaning and rinsing 3 times, all supported as required with multiple frequency ultrasound of the switchable frequencies 40 and 80 kHz, in Normal, Sweep or Pulse operation.
- Microprocessor-controlled and permanently monitored cleaning processes.
- Gentle vacuum drying with radiant heat below 100 mbar absolute, supported if necessary by spinning up to 1400 rpm.
- Predefined standard cleaning programs.
- Additional cleaning programs freely definable by the user are possible.
- Reliable extraction of the solvent vapours via exhaust air connections to the open air or absorption in an optional activated carbon based absorber unit.
- Suitable for solvents with flashpoint  $\geq 12$  °C.

### 3.3

#### Scope of delivery

- Elmasolvex<sup>®</sup>VA watch cleaning unit
- Elma basket mounting for 5 basket inserts Ø 80 mm (optional accessories)
- 4 media tanks with suction filters and labels
- 4 spare suction filters for media tanks
- Mains cable
- Funnel
- 2 exhaust air tubes (5 m) with coupling (for extraction of escaping vapours)
- USB cable
- Allen key 1.5 mm for mounting the protective grille
- 2 plastic plugs
- Operating manual

### 3.4

#### Optional accessories

- 2 different movement holders for not dismantled watch movements for accommodation of up to 12 movements
- Basket inserts with different division and height, electro polished or plastic-coated design
- Miniature basket
- Pager – hand-held device for mobile remaining time interrogation of the cleaning program
- Activated carbon unit for absorption of solvent vapours (alternative extraction to the discharge tubes from the scope of delivery)

## 3.5

**CE conformity**

This small parts cleaning unit fulfils the CE marking criteria with regard to the Machinery Directive 2006/42/EC, the EMC Directive 2004/108/EC and the ATEX Directive 94/9/EC.

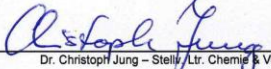
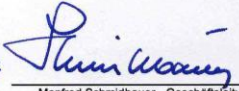
<b>EG-Konformitätserklärung / Declaration of conformity Déclaration de conformité CE / Dichiarazione di conformità / Confirmación CE</b>	
Wir / We / Nous / Noi / Nosotros:	
 Elma - Hans Schmidbauer GmbH & Co. KG, Kolpingstr. 1-7, 78224 Singen / Hohentwiel Deutschland / Germany / Allemagne / Germania / Alemania	
erklären in alleiniger Verantwortung, dass das Produkt <i>declare under our sole responsibility that the product; déclarons sous notre seule responsabilité que le produit; dichiariamo sotto la nostra unica responsabilità che il prodotto; declaramos bajo la responsabilidad única que el producto</i>	
Bezeichnung / name / nom / descrizione / denominación:	<b>(Uhren-) Kleinteile-Reinigungsmaschine</b>
Typ / type / typ / tipo / tipo:	<b>Elmasolvex VA</b>
auf das sich diese Erklärung bezieht, mit den Bestimmungen der folgenden EG-Richtlinie(n) und Norm(en) oder normativen Dokument(en) übereinstimmt: <i>to which this declaration relates, is in conformity with the provisions of following EC-Directive(s) and standard(s) or normative document(s):</i> auquel se réfère cette déclaration, est conforme aux dispositions de la (des) directive(s) CE et à la (aux) norme(s) ou document(s) normatif(s) suivants: a cui si riferisce la presente dichiarazione, è conforme alle disposizioni della/e seguente/i direttiva/e e norma/e CE o all'ai seguente/i documento/i dispositivo/i: al que se refiere la presente declaración cumple con las disposiciones de la(s) siguientes directiva(s) comunitaria(s) y norma(s) o con lo(s) documento(s) normativo(s):	
<b>Maschinenrichtlinie</b>	<i>(machinery directive / directive aux machines / direttiva machine / directiva de máquinas)</i>
<b>2006 / 42 / EWG (EC / EEC)</b>	
Harmonisierte Normen *	<i>(harmonized standards / standards harmonisés / standard armonizzati / normas armonizadas)*</i>
EN ISO 12100; EN ISO 13849-1; EN 1127-1 Abschnitt (chapter / section / sezione / párrafo) 1-5, 6.1-6.5, 7	
<b>EMV-Richtlinie</b>	<i>(EMC-directive / CEM-directive / direttiva CEM / directiva CEM)</i>
<b>2004 / 108 / EWG (EC / EEC)</b>	
Harmonisierte Normen *	<i>(harmonized standards / standards harmonisés / standard armonizzati / normas armonizadas)*</i>
EN 61326-1	
<b>RoHS-Richtlinie</b>	<i>(RoHS-directive / directive RoHS / direttiva RoHS / directiva RoHS)</i>
<b>2011 / 65 / EWG (EC / EEC)</b>	
Für die <b>Explosionssicherheit</b> kamen folgende Normen* zur Anwendung: <i>The safety against explosion is based on the following standards*/la sécurité contre les explosions est basé sur les normes* suivantes: / per la sicurezza contro le esplosioni sono state applicate le seguenti norme*/para la seguridad contra explosiones se han aplicado las normas* siguientes:</i> <b>EN 60079-0; EN 60079-26; EN 13463-1; EN 13463-5; EN 13463-6; EN 13463-8;                  EN 1127-1 Abschnitt (chapter / section / sezione / párrafo) 1-5, 6.1-6.4, 7; EN 60079-10-1</b>	
Zusätzlich gegeben: <i>(Additionally tested / en outre testé / sono stati inoltre testati / comprobación adicional):</i> <b>Sicherheitskonzept in Anlehnung an:</b> <i>(safety concept according to: / concept de sécurité en référence à:/concepto di sicurezza in conformità a: / concepto de seguridad según:</i> <i>(ATEX directive / ATEX directive / direttiva ATEX / directiva ATEX)</i>	
<b>ATEX-Richtlinie</b>	<i>(ATEX directive / ATEX directive / direttiva ATEX / directiva ATEX)</i>
<b>94 / 9 / EWG (EC / EEC)</b>	
Die Dokumentation wurde bei der benannten Stelle <b>0035 (TÜV Rheinland)</b> unter der Nummer <b>557/Ex-Ab 1901/12</b> hinterlegt. <i>The documentation has been lodged at the named organization 0035 (TÜV Rheinland) with number 557/Ex-Ab 1901/12</i> <i>La documentation a été déposée auprès de l'organisme notifié 0035 (TÜV Rheinland) sous le numéro 557/Ex-Ab 1901/12</i> <i>La documentazione è stata depositata presso l'organismo citato 0035 (TÜV Rheinland) al numero 557/Ex-Ab 1901/12</i> <i>La documentación se ha presentado al organismo notificado 0035 (TÜV Rheinland) con el número 557/Ex-Ab 1901/12</i>	
* Der verwendete Normenstand entspricht dem Stand der Ausfertigung der Konformitätserklärung * The version of the standards used corresponds with the version of the issue of the declaration of conformity * L'état des normes utilisé correspond à l'état final de la copie de la déclaration de conformité * Gli standard normativi applicati corrispondono allo stato della stesura della dichiarazione di conformità * La versión de las normas utilizadas corresponde a la versión de la expedición de la declaración de conformidad	
Bevollmächtigte Person für die Zusammenstellung der technischen Dokumentation: <i>Authorised person to compile the technical file / personne autorisée à constituer le dossier technique / persona autorizzata a costituire il fascicolo tecnico / persona facultada para elaborar el expediente técnico:</i>  Dr. Christoph Jung - Stellv. Lfr. Chemie & Verfahrenstechnik	15.1.2014  Manfred Schmidbauer - Geschäftsleitung

## 3.6

## Technical Data

<b>Mechanics</b>	
Case external dim. D/H (approx. mm)	600 / 610
Unit external dim. W/D/H (approx. mm)	600 / 590 / 610
Weight incl. media tanks (approx. kg)	39
Number of media tanks (pcs.)	4
Volume per media tank (l)	2.5
Exhaust air connections	2 x DN6 (passive)
<b>Electronics</b>	
Mains voltage variant (V AC / Hz)	230 / 50/60
Mains voltage variant (V AC / Hz)	115 / 60
Mains voltage variant (V AC / Hz)	100 / 50/60
Mains input fuse	2 x T4A / 250 V see rating plate
Mains cable cross section	3 x 1.0 mm <sup>2</sup>
Switchable ultrasound frequencies (kHz)	40 / 80
Maximum total power consumption (W)	220
Effective ultrasound power (W), can be regulated 30% - 100%	50
Power consumption in standby (W)	20
Spinning mode speed range freely adjustable up to max. (rpm)	1400
Cleaning / rinsing mode rotation speed range (rpm)	1 - 20
Oscillation / vibration frequency rate (1/s)	1 – 14
Oscillation / vibration mode deflection (°)	1 – 60
Operation sound pressure level <sup>1</sup> (LpAU)	< 70 dB
<b>Accessories</b>	
Individual basket external dimensions D/H (approx. mm)	80 / 10 or 64 / 12
Number of individual baskets in the basket holder	5 or 3
Maximum load, complete cleaning basket (all individual baskets together) (approx. g)	100 or 60
Movement holder maximum movement capacity (pcs.)	12
Activated carbon absorption unit	passive

<sup>1</sup> measured maximum sound pressure level at 1 m distance

## 3.7

## Unit front side description

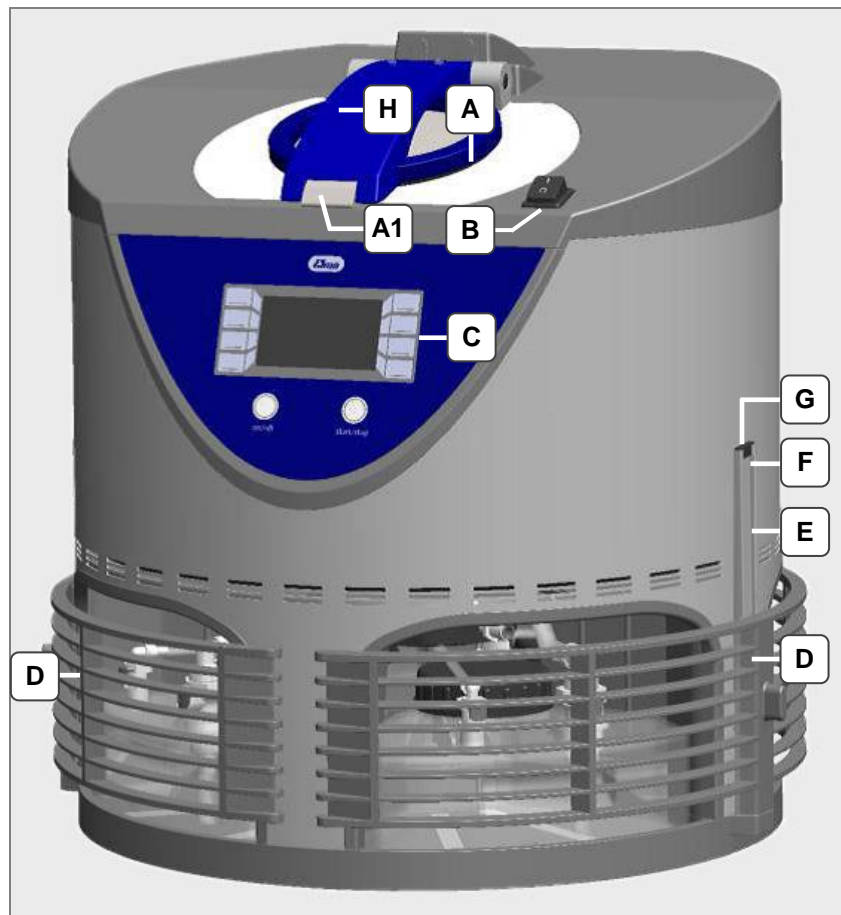

Fig. 3.7.1 View of front side

- A** **Cleaning chamber cover** with snap lock (A1) for engaging the cover
- B** **Main switch** for switching on the cleaning unit
- C** **Control panel with display** Detail description *Chapter 3.9*
- D** **Protective grille above media tanks with cleaning and rinsing liquid** - can be moved up for removal of the media tanks
- E** **Guide rail for media tanks protective grille** The protective grille is inserted here by the user before the first start-up
- F** **Screw as stop for the top end position when moving the protective grille upwards.** The screw must be installed by the user after attaching the protective grille
- F** **Plastic cap** must be plugged to the end of the guiding rail
- H** **Screw for venting the cleaning chamber** in the event of a fault (see *Chapter 11.3.2*)

### 3.8

### Unit rear side description

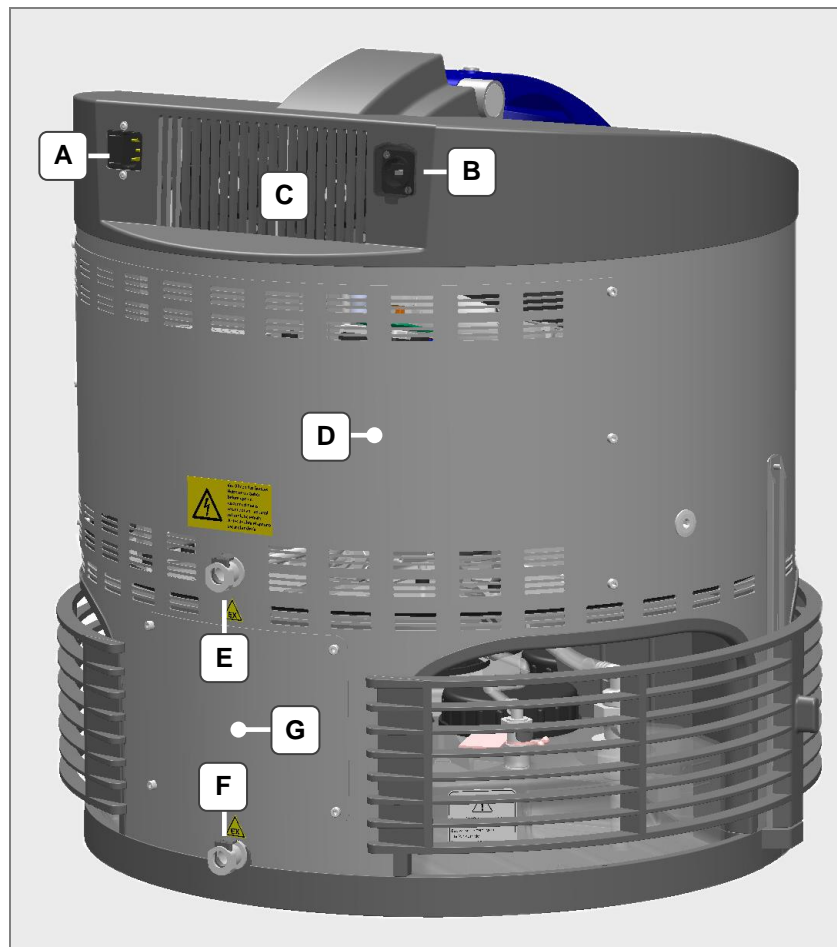

Fig. 3.8.1 View of rear side

- A Connection for mains cable** and slot for fuse
- B USB service connection** (only for service purposes)
- C Fan openings** must be freely accessible for the necessary ventilation and cooling of the cleaning unit
- D Service opening "cleaning unit"**
- E Connection for venting the cleaning chamber** Instructions for use of the Elma exhaust air tube (included in the scope of delivery) or with the Elma activated carbon unit (optional accessory) (*Chapter 4.3 Connecting activated carbon unit or exhaust air tubes*)
- F Connection for venting the media tanks** Connection instructions for use of the Elma exhaust air tube or connection with Elma activated carbon unit (*Chapter 4.3 Connecting activated carbon unit or exhaust air tubes*)
- G Service opening "deflagration protection"** for protection against flashback of open flames into the cleaning unit

## 3.9

**Control panel description**

Fig. 3.9.1 View of control panel

- A Operating buttons** for selecting functions and settings and navigation in the software menu
- B On / Standby button** for switching on the control panel
- C Start / Pause button** for starting or interrupting the cleaning process
- D Display** shows the setting options and the current status of the cleaning process

## 3.10

**Handling of the control panel**

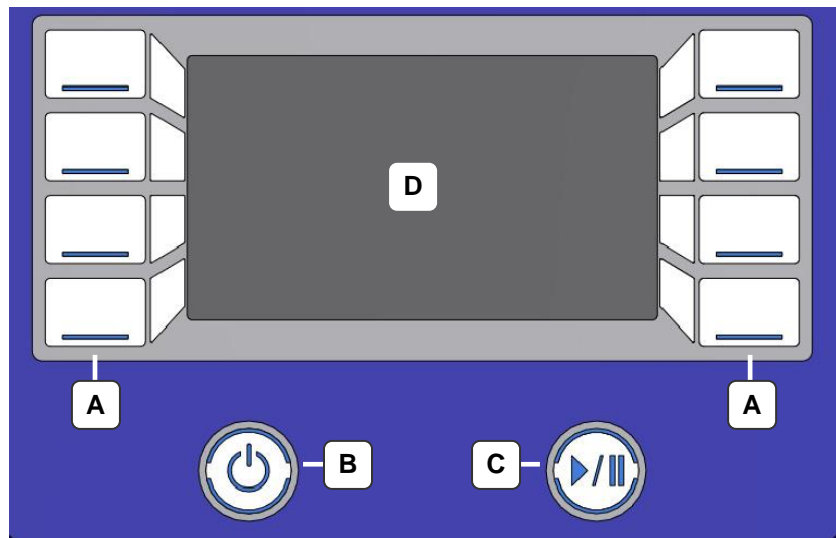
Fig. 3.10.1 Control panel with display and navigation symbols

- A Operating buttons** control the respective navigation symbols shown on the display
- B Navigation symbols** show the context-dependent functions of the appropriate operating buttons

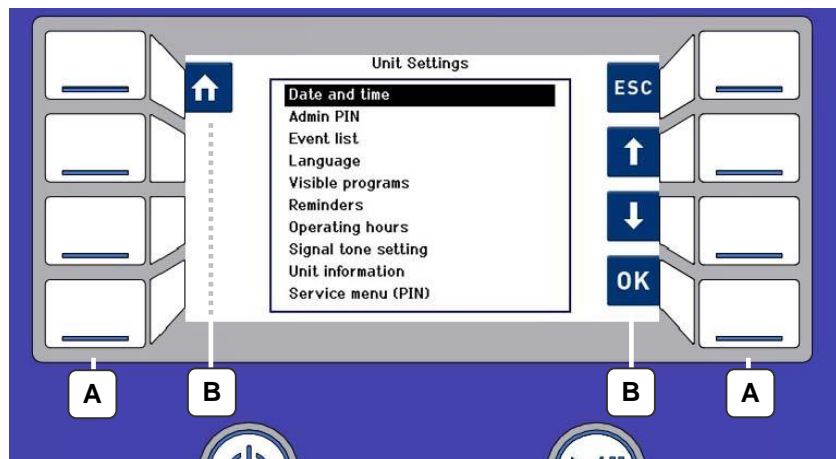

The control panel is not a touch-sensitive user interface (touch screen).

Controls and settings on the unit are made using the respective operating button assigned to the navigation symbol.

The operating buttons only have to be pressed for a short time (< approx. 0.5 sec.) for the actuation.

### Handling instructions

Explanation of the handling instructions for operating steps in this manual:

The instruction to press an appropriate navigation symbol always refers to the respective assigned operating button.

## 3.11

### Description of the navigation symbols

The activation of the respective navigation symbol using the assigned operating button triggers the following actions:



Navigates back to the display *Program Select List* (home screen)



Navigates to the *Unit Settings* menu



Confirms an entry



Discards any previously made input and navigates back to the previous display



Navigates up by one menu item in the menu selection



Navigates down by one menu item in the menu selection



Navigates one step to the left in the screen display



Navigates one step to the right in the screen display



Increases the value in a selection field



Reduces the value in a selection field



Adopts an entry



Refers to further information



Indicates that the pager (optional accessory) can be initialised



Refers to the description of a fault



Editing program



Reset reminder / Remind again



## 3.12

**Cleaning chamber description**

Fig. 3.12.1 View of cleaning chamber

- A Ventilation openings**
- B Filling level sensor** Work level with 2 guard rails
- C Filling level sensor** Overfilling level
- D Cleaning basket mounting**
- E Sieve insert** (mesh size 0.36 mm) for collecting lost precision parts and coarse particles when draining the cleaning / rinsing liquid from the cleaning chamber. The sieve can be removed for cleaning.

When reinstalling the sieve, it must be screwed in as far as the stop. Check freedom of movement of the cleaning basket afterwards (collision hazard if the sieve insert has not been screwed in correctly).

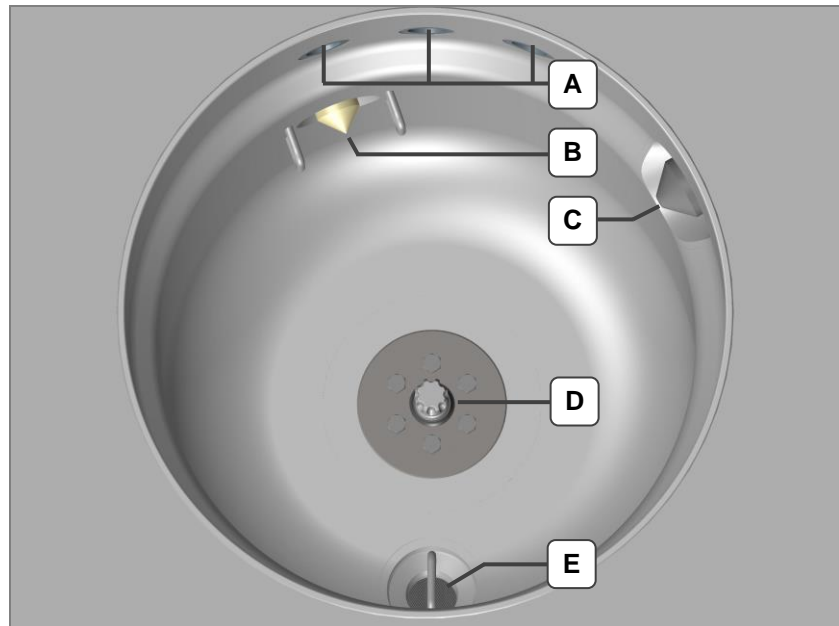

Never operate cleaning unit without sieve insert. Danger of damage in the cleaning unit!

### 3.13 Media tanks description

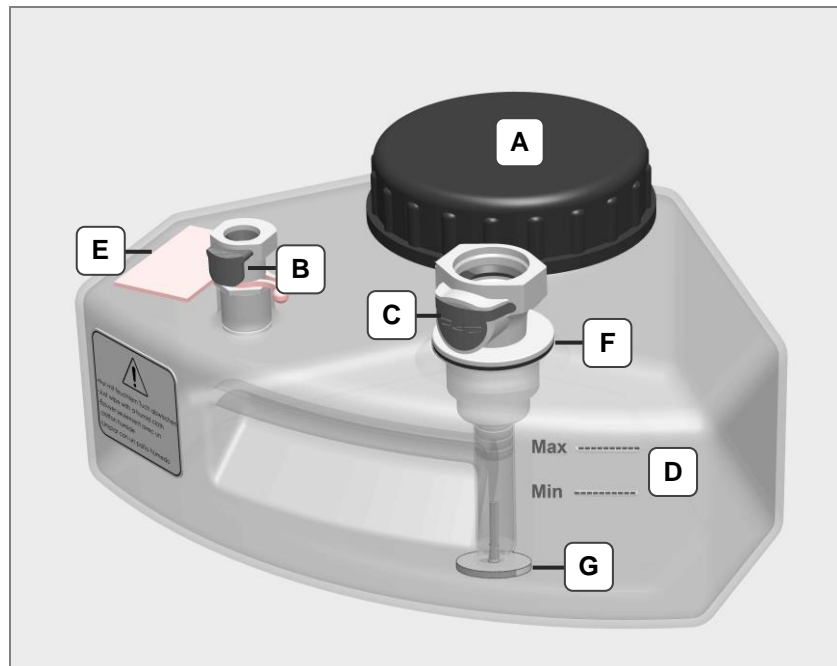

Fig. 3.13.2 Media tanks

- A Screw cap**
- B Media tank (small) venting quick-action coupling with shut-off valve**
- C Media tank (large) quick-action coupling media inlet and outlet with shut-off valve**
- D Filling level marking**
- E Label for marking the media tank**
- F Seal**
- G Suction filter (see Chapter 3.13.1)**

#### 3.13.1 Suction filter functionality

During suction of the medium, the medium must flow through the suction filter (*Fig. 3.13.1.G*) (in this way, only filtered medium reaches the cleaning chamber).

When draining the medium, the suction filter automatically sinks to the bottom of the tank so that unfiltered medium flows into the media tank.

The cleaned soiling thus gets into the canister unhindered and is kept in the media tank during the next filling of the cleaning chamber.



Observe the cleaning and replacement intervals (see *Chapter 9.2.2*).

## 4 Before the initial commissioning

### 4.1 Unpacking and installing the cleaning unit

<b>Packaging</b>	Keep the packaging for possible service purposes. Any disposal must be made in accordance with the applicable disposal regulations. You can also send the packaging back to the manufacturer or supplier.
<b>Handling of the machine</b>	Due to its weight the machine must be handled by 2 persons! Reach into the openings (where Media containers are placed) to lift up / carry the machine
<b>Inspection for transport damage</b>	Inspect the cleaning unit for possible transport damage before the first start-up. The cleaning unit must not be put into operation in the case of recognisable damage. Contact your supplier and the carrier.
<b>Installation surface</b>	Place the cleaning unit for operation on a stable, level, dry base which is resistant to the cleaning liquid. A smooth installation surface is required to be able to rotate the cleaning unit when changing the cleaning liquid.



**DANGER**

---

Danger of electric shock due to ingress of liquid!

Protect the cleaning unit against the ingress of liquid.

The interior of the cleaning unit is protected against dripping moisture from outside (IP class 20).

However, keep the installation surface and the case dry to prevent electrical accidents and damage to the cleaning unit.

---

**Ambient conditions** Provide sufficient ventilation at the location of the cleaning unit.

The following requirements must be met for safe operation of this cleaning unit:

- Permitted ambient temperature in operation: +10°C - +30 °C
- Permitted relative humidity in operation: max. 80%
- Operation is only permitted in well-ventilated areas
- The surroundings must not have high dust levels



---

#### Fire and explosion hazard!

Ignitable vapours of the cleaning and rinsing media can escape in the case of improper operation without exhaust air tubes / without activated carbon unit and when changing the cleaning liquids.

Smoking and open ignition sources are prohibited in the unit surroundings.

Maximum one day's requirement of the solvents used is permitted to be stored in the surroundings of the cleaning unit at a minimum distance of 3 m from the cleaning unit.

---

## 4.2

### Attaching protective grilles

The protective grilles in front of the media tanks are not attached when the unit is delivered.

Procedure for attaching protective grilles:

1. Remove the grub screws in each case (*Fig. 4.2.1.A*) at the top ends of the two guide rails.  
Required tool: 1.5 mm Allen key (included in the scope of delivery).
2. Insert the two protective grilles with the carriage (*Fig. 4.2.1.B*) in each case from above into the guide rails.
3. Screw the grub screws back into the top ends of the guide rails.  
Attention! The grub screws must not be screwed in too far otherwise they can fall to the back out of the threads.
4. Place the plastic cap (*Fig. 4.2.1.B*) on to the edge of the guiding rail.

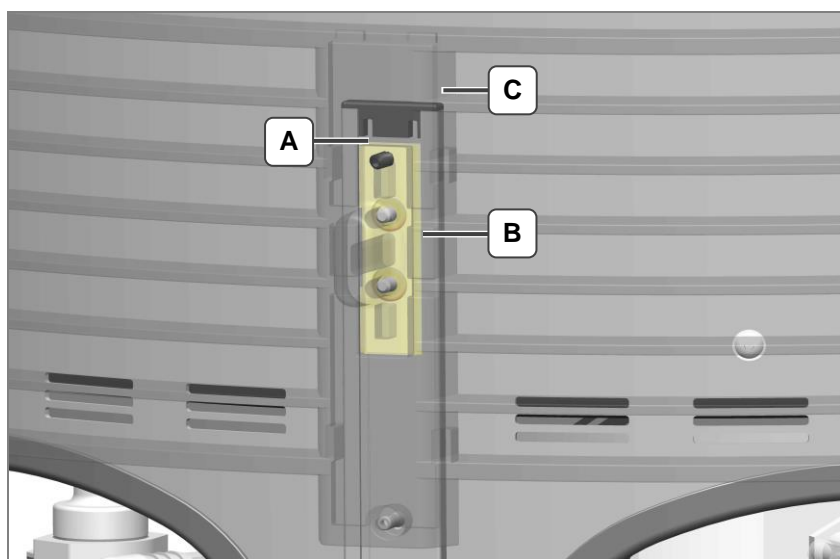

Fig. 4.2.1 Protective grilles guide mechanism

## 4.3

### Connecting activated carbon unit or exhaust air tubes



Due to the process, vapours of the cleaning and rinsing media discharge at the openings provided for them on the rear side of the cleaning unit (*Fig. 4.3.1.A/B*). This area is considered as an area with increased risk of explosion if the safety precautions are not complied with.

Two variants are provided for extracting vapours of the cleaning and rinsing media:

- Activated carbon unit (optional accessory Art. No. 105 3376)
- Exhaust air tubes (included in the scope of delivery) for connection to an authorised central extractor for this or transfer to the open air.

It is mandatory to connect either the exhaust air tubes (included in the scope of delivery) or the activated carbon unit (optional accessory) to these outlets.



Attention! Danger from explosion / deflagration in the area of the ventilation openings of the cleaning unit.

Observe the applicable safety regulations for handling flammable media.

Keep all kinds of ignition sources away from the danger area.

Prevent ignition sparks from electrostatic discharge.

Use the activated carbon unit or exhaust air tubes protection measures described in this chapter.

Strictly observe the protection measures shown here.

#### Connecting exhaust air tube variant

Connect the 2 exhaust air tubes (included in the scope of delivery) to the respective connections *Fig. 4.3.1.A* and *Fig. 4.3.1.B*.

In doing so, the connection coupling must audibly engage in each case.



Attention! Danger from explosion / deflagration!

Solvent vapours discharge at the ends of the exhaust air tubes during the cleaning operation. This area is considered as a potentially explosive area.

Either place the ends of the exhaust air tubes (maximum tube length 5 metres) in the open air or connect them to an authorised central extractor.

Keep ignition sources away from the ends of the exhaust air tubes.



The danger areas are marked with the appropriate warning sticker.



Danger of damage to the unit. The ends of the exhaust air tubes must be freely accessible to a ventilated area and must not be immersed in water!

Only use the activated carbon unit from the Elma accessories.

If it is not possible on-site to use the exhaust air tube (no access to the open air and no permissible extraction equipment), it is possible to connect the Elma activated carbon unit instead of the exhaust air tubes.

When using the activated carbon unit, explosion protection is guaranteed provided the specified replacement intervals (see *Chapter 14.3.2*) are complied with. However, unpleasant odours cannot be completely ruled out.

### Connecting activated carbon unit variant

Strictly connect the 2 connection tubes of the activated carbon unit (optional accessory) correctly to the connections *Fig. 4.3.1.A* and *Fig. 4.3.1.B*.

In doing so, the connection coupling must audibly engage in each case.

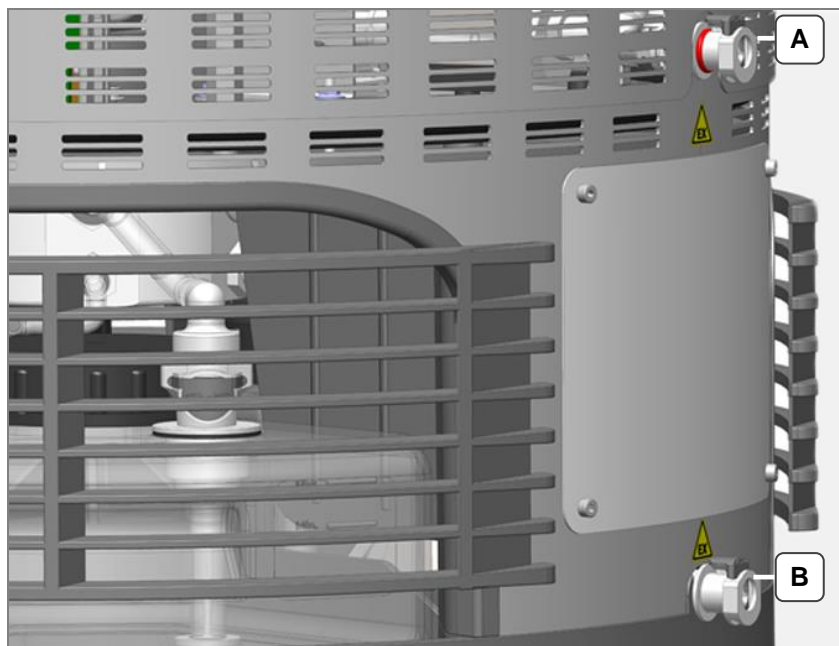

Fig. 4.3.1 Ventilation connections



For further information about connection, handling and servicing of the activated carbon unit see *Chapter 14*.

## 4.4

### Filling media tank

There are 4 media tanks for the respective cleaning and rinsing media located in the bottom area of the cleaning unit.

Fill the media tanks with the cleaning and rinsing media recommended for them (*Chapter 8*).

The individual media tanks must be filled with cleaning or rinsing solution according to the position in the cleaning unit.

Removable labels are attached to the media tanks for individual assignment and recognition of the filled media (*Fig. 4.4.3.E*).

#### Positions of the media tanks

For recognition of the respective position, there are markings on the case and the support surface under the media tanks (1-2-3-4).

Media tank in position #1: **Cleaning medium**

Media tank in position #2: **Rinsing medium**

Media tank in position #3: **Rinsing medium**

Media tank in position #4: **Rinsing medium**

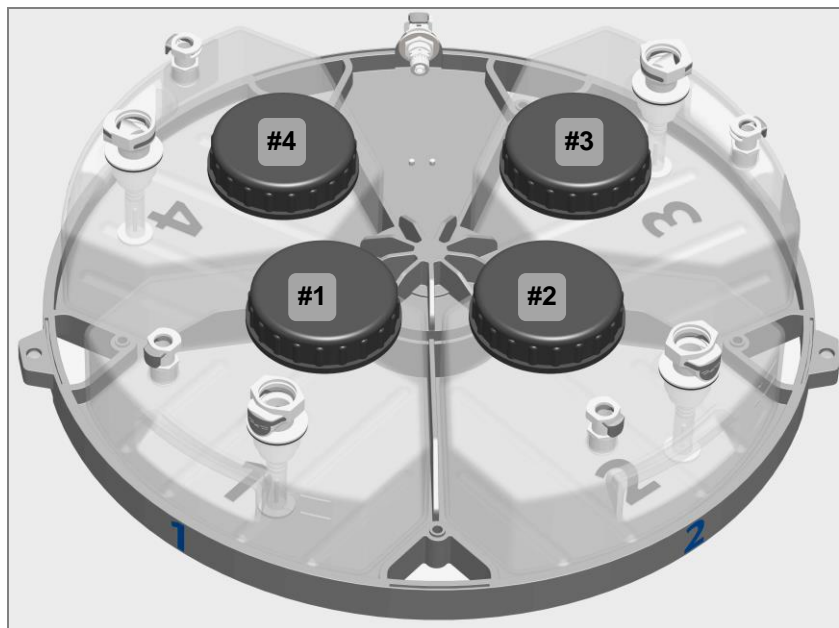

Fig. 4.4.1 Illustration of the positions of the media tanks

#### Never operate with unfilled or missing media tanks!

All 4 media tanks must be filled with suitable operating materials to be able to put the cleaning unit into operation.

Operation with unfilled or missing media tanks results in unsatisfactory cleaning results or automatic abortion of the cleaning process.

**Only use permitted operating materials.**

Only permitted operating materials must be used for safety reasons and to prevent unit damage.

**Do not remove during operation.**

The media tanks must only be removed when the cleaning unit is switched off (empty cleaning chamber) for safety reasons.

Observe the instructions for recommended operating materials and restrictions for operating materials (*Chapter 8*).

---



Fire and explosion hazard!

When handling flammable materials, observe the applicable safety regulations according to the safety data sheet of the respective solvent.

Keep all kinds of ignition sources away.

Prevent ignition sparks from electrostatic discharge. Discharge possible electrostatic charges (body charge) by touching any grounded equipment before handling flammable materials: e.g. water tap, metal surface of the case of the cleaning unit or use ESD protective equipment (ESD arm band).

If liquid escapes while replacing the media tank, this must only be removed using a dry cloth (to prevent electrostatic charging).

---

**Procedure for filling media tank**

Start with the media tank #1 (*Fig. 4.4.1.#1*):

1. Push up the covers for the media tanks (*Fig. 4.4.2.A/A*).
2. Unlock the shut-off valves for the tube connections:  
Press the respective unlocking button on the shut-off valve of the media tank (*Fig. 4.4.3.B/C*) and pull the tube connection upwards out of the shut-off valve at the same time.
3. Remove the media tank from the cleaning unit using the recessed handle.
4. Open the screw cap and fill the media tank with the suitable cleaning medium up to a filling level between the *Min* – *Max* markings (*Fig. 4.4.3.D*).



  
ATTENTION

The filling level of the operating materials must always be between the markings (*Fig. 4.4.3.D*) to guarantee proper operation of the cleaning unit and an optimal cleaning result.

Too low a filling level (below the *Min* marking) causes errors in the cleaning program with unsatisfactory results.

Overfilling (above the *Max* marking) can result in liquid discharging at the case outlet at the bottom and possibly destroying the activated carbon unit.



The volume above the *Max* marking is also used as reserve for possible liquid entrainments.

5. Check the shut-off valves of the quick couplings on the media tank and the media tubes for correct function (*Chapter 4.4.1*).
6. Replace the tank in the cleaning unit.
7. Reconnect the tube couplings to the media tanks. The tube couplings must audibly engage in the shut-off valves. Also visually inspect the secure seating of the tube couplings.

**Attention!** After the engagement, the push button on the tube coupling (C) must be completely disengaged. Check by shaking and pulling on the tube coupling whether it is correctly connected.

8. Proceed in the same way with the media tanks #2 - #3 - #4 for the rinsing media.

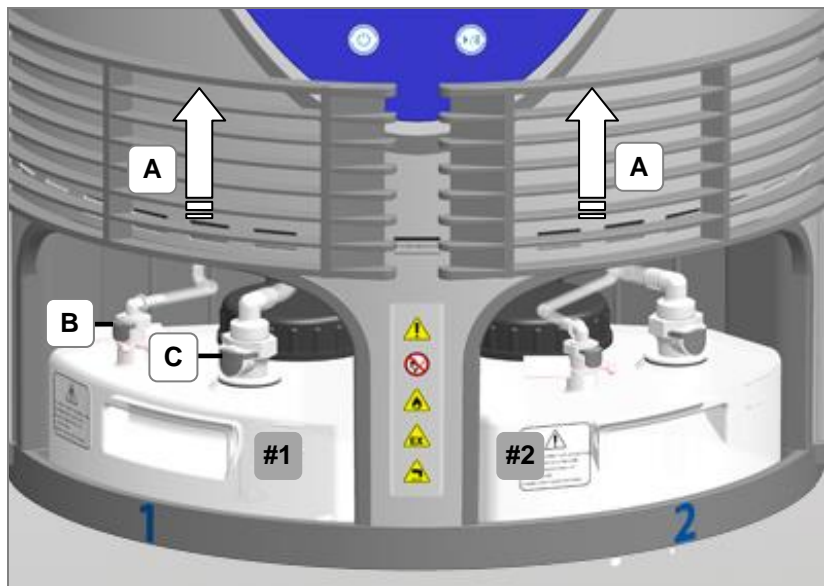

Fig. 4.4.2 Media tank cover opened

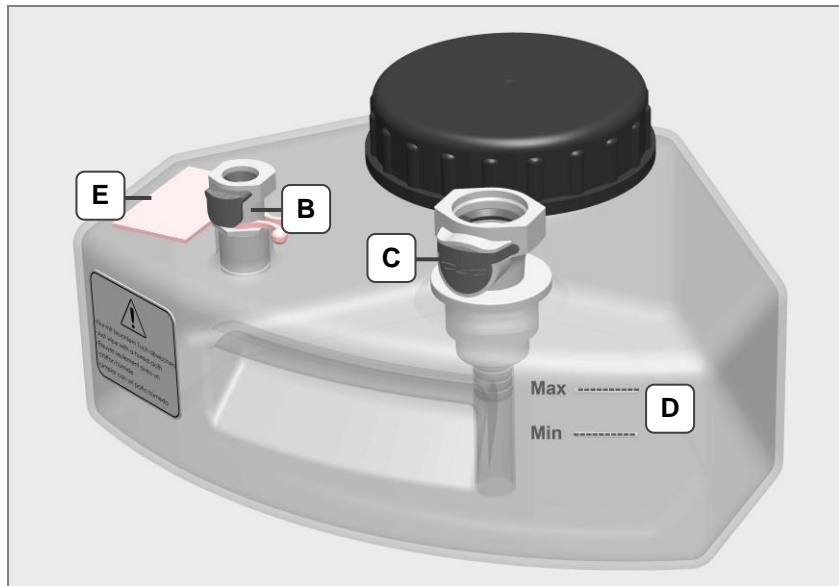

Fig. 4.4.3 Media tanks

#### 4.4.1

### Checking shut-off valves of the quick couplings



The shut-off valves of the quick couplings automatically seal the media tanks and the media tubes if both quick coupling parts are not connected to each other. Check the correct function of the shut-off valves at every media change.

#### Procedure

Press the nipple of the shut-off valve a few millimetres into the coupling to check the shut-off function. After releasing, the shut-off valve must spring back outside to the "closed" position (arrow direction).

#### Media tank quick coupling

The shut-off valve (*Fig. 4.4.1.1.F*) is moveable and in the not connected state must be flush with the guide bar (*Fig. 4.4.1.1.G*).

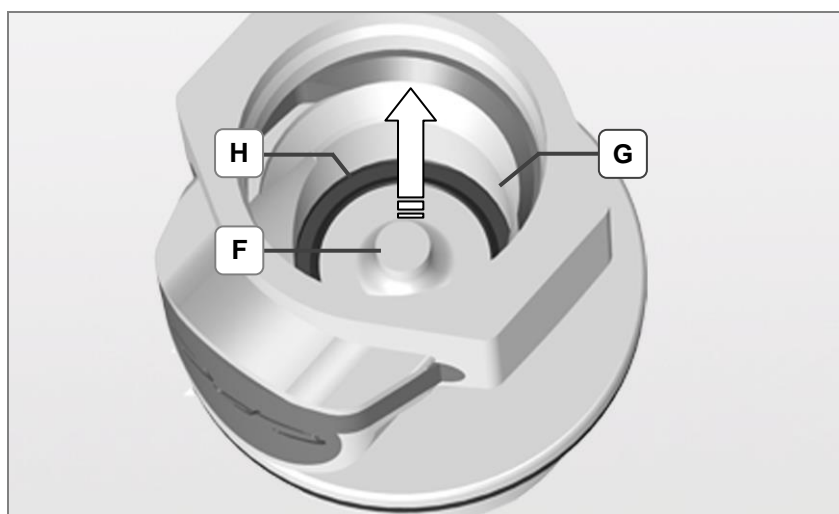

Fig. 4.4.1.1 Media tank quick coupling "closed"

**Media tube quick coupling**

The shut-off valve is moveable. The nipple of the shut-off valve (Fig. 4.4.1.2.J) in the not connected state must protrude over the edge of the quick coupling.

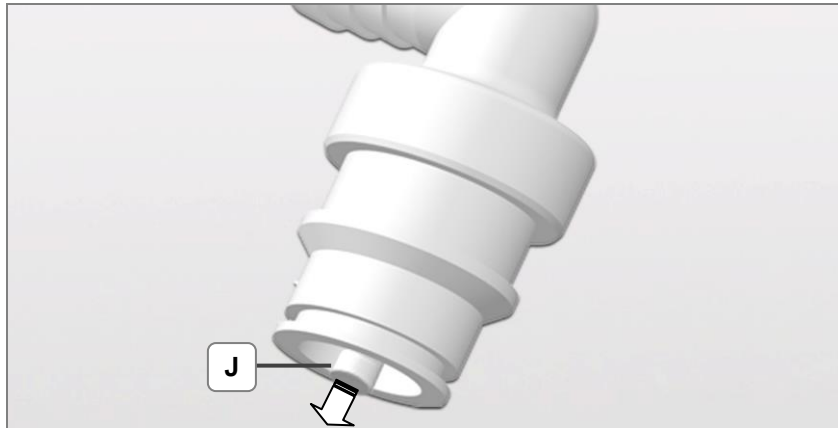

Fig. 4.4.1.2 Media tube quick coupling "closed"

**Checking seal in the quick coupling of the media tube**

Check the seal is seated correctly: Fig. 4.4.1.3.H correct seating. Fig. 4.4.1.4.H incorrect seating!

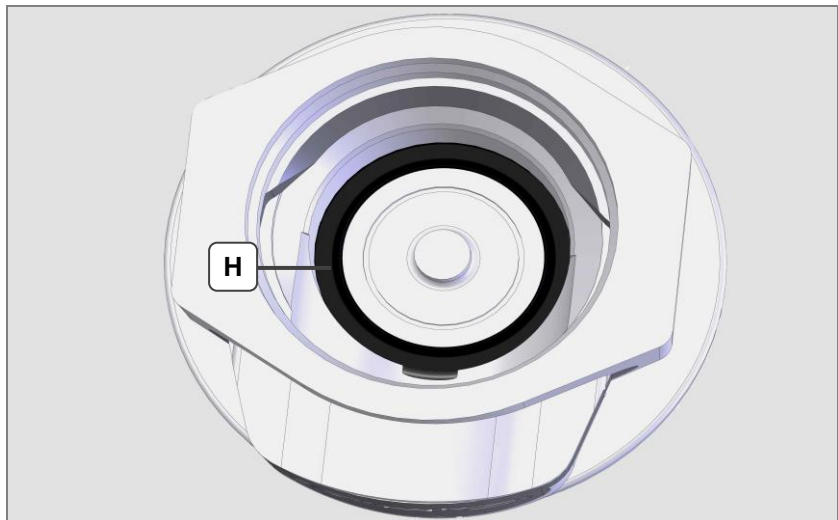

Fig. 4.4.1.3 Seal OK

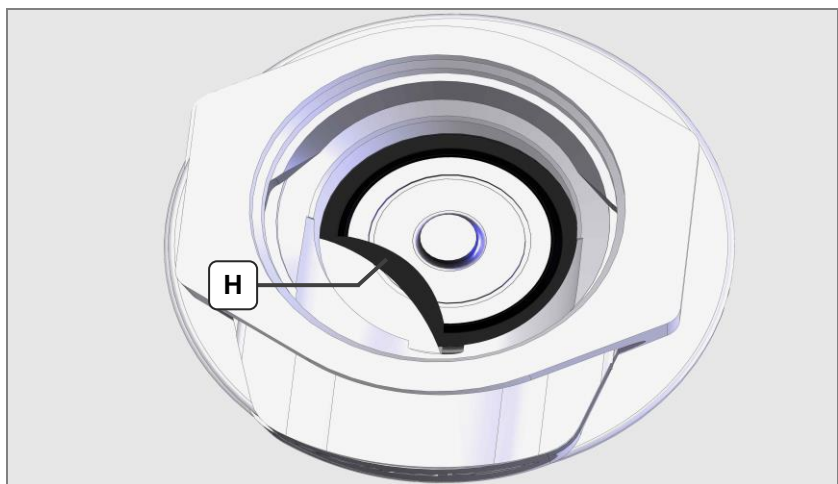

Fig. 4.4.1.4 Seal not OK!

## 5 Initial commissioning

### 5.1 Connecting cleaning unit to mains power supply

- Required grid conditions** The connection conditions must match the information on the rating plate.
- Connecting mains cable** Connect the mains cable (included in the scope of delivery).  
The cleaning unit must only be connected to a grounded power socket.  
The mains plug must only be connected to an easily accessible power socket as it is considered as a disconnecter!

### 5.2 Switching on cleaning unit

- Switching on main switch** Switch on the cleaning unit at the main switch (*Fig. 3.7.1.B*).  
The internal fans are started (fan noise audible).  
The blue LED in the On/Standby button (*Fig. 3.9.1.B*) flashes.
- Switching on control panel** Switch on the control panel by pressing the On/Standby button (*Fig. 3.9.1.B*).  
The blue LED in the On/Standby button (*Fig. 3.9.1.B*) lights.  
The start screen (*Fig. 5.3.1*) is displayed for 5 seconds.

### 5.3 Selecting language in the display



A language must initially be selected when first switching on (for handling see *Chapter 3.10*). The display does not change to the next step until then.

The language in the display set at the factory is German.  
Confirm or change the language by pressing the appropriate operating button.

The selected language is shown on the display (*Fig. 5.3.1.A*).



Fig. 5.3.1 Display user language

The display now automatically changes to the interrogation of the filling of the media tanks (*Fig. 6.1.1 Chapter 6.1*).

## 6 Daily cleaning operation

**Switching on main switch** Switch on the cleaning unit at the main switch (Fig. 3.7.1.B).

The internal fans are started (fan noise audible).

**Switching on control panel** Switch on the control panel by pressing the On/Standby button (Fig. 3.9.1.B).

The start screen (Fig. 5.3.1) is displayed for 5 seconds.

The display automatically changes to the interrogation of the media filling levels.

### 6.1 Checking filling levels of the media tanks

**Checking media tank filling level** The retrieval of the filling levels of the media tanks is shown on the display (Fig. 6.1.1).

Check the filling levels and fill or empty the media tanks if required to the correct filling level (Chapter 4.4).

Confirm the correct filling levels with **OK**.



Fig. 6.1.1 Display *Check filling level of the media tanks*

The display automatically switches to the Start menu with display of the cleaning programs (Fig. 6.3.1).

## 6.2 Loading and inserting cleaning basket

The cleaning unit is equipped with a cleaning basket at the factory.



Note the following instructions before operation of the cleaning basket in order to prevent damage to the product to be cleaned and cleaning unit.

Only use the original Elma cleaning basket.

The maximum load weight of the cleaning basket is 100 grams.

### Opening cleaning chamber

Open the cover of the cleaning chamber by slightly lifting the snap connector at the front end of the cover handle (Fig. 3.7.1.A1).

### Removing cleaning basket

The cleaning basket mounting shaft is only placed in the coupling of the basket mounting (locking by engaging in a ball gripper).

Remove the cleaning basket by pulling upwards.

### Opening cleaning basket

Press the basket locking down (Fig. 6.2.1.A1) and simultaneously turn (Fig. 6.2.1.A2) anticlockwise to open the cleaning basket (bayonet connection).

The individual basket inserts (Fig. 6.2.2.B) can now be removed from the basket holder (Fig. 6.2.2.C).

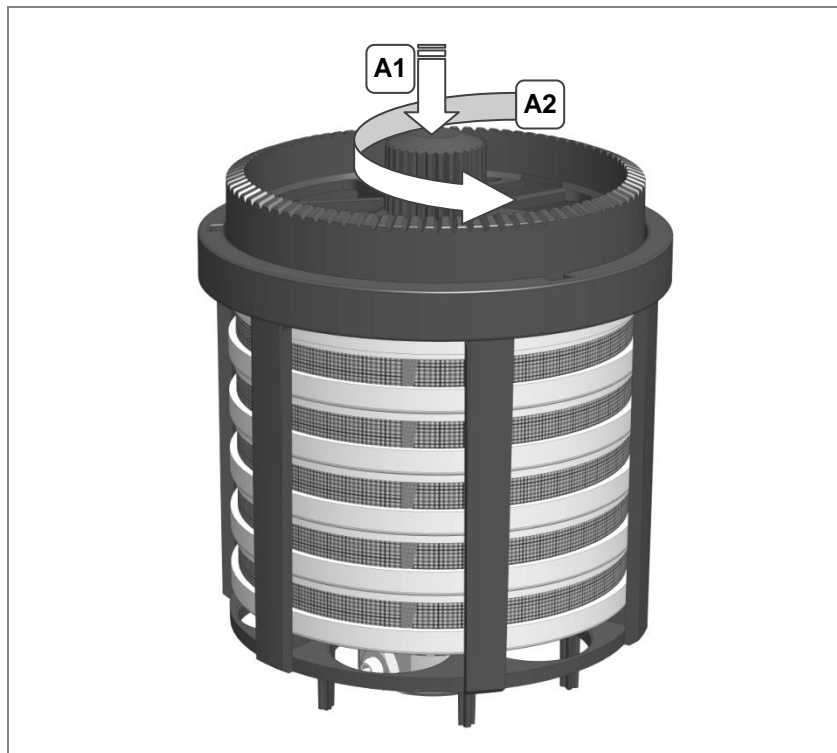

Fig. 6.2.1 Opening cleaning basket

**Loading basket inserts**

The basket inserts are designed differently for accommodation of the various parts to be cleaned. Pay attention during the loading that sensitive parts are placed with appropriate care in the suitable basket compartments.

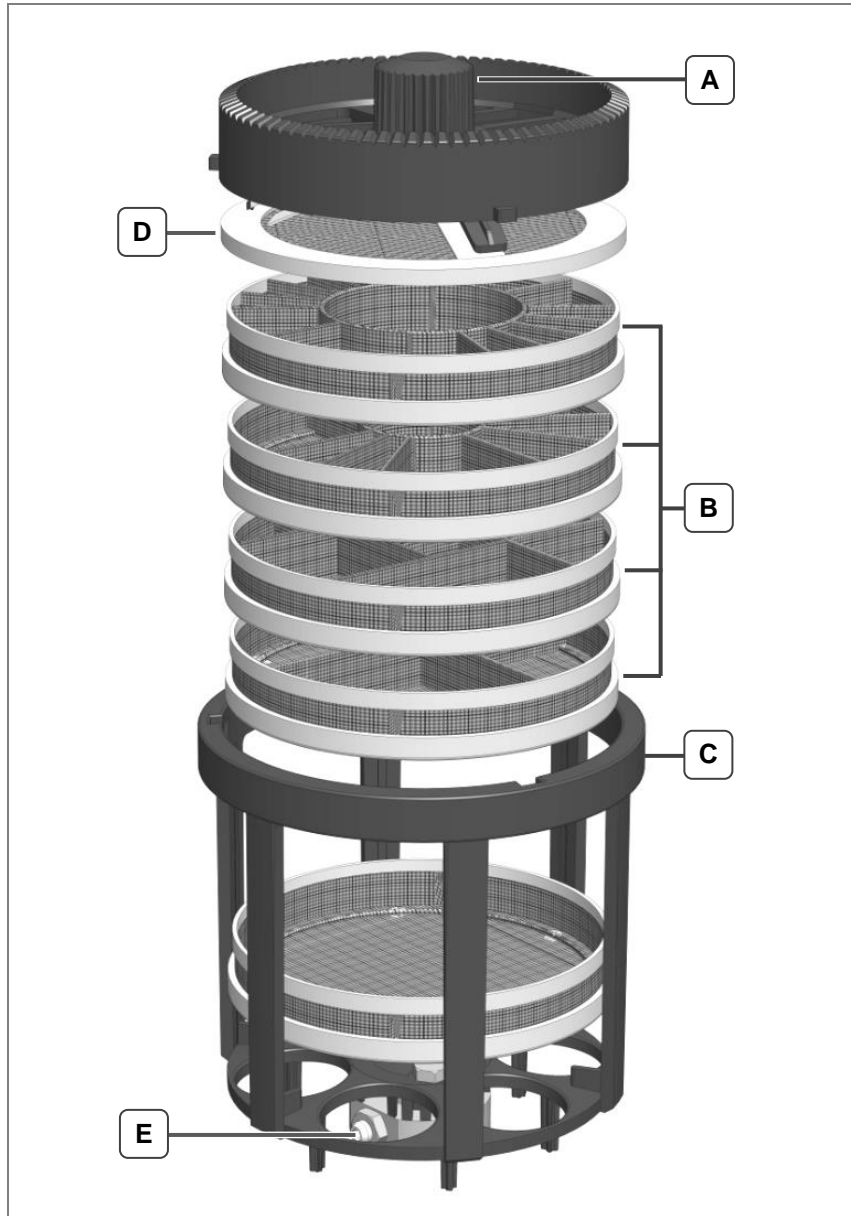

Fig. 6.2.2 Cleaning basket structure

**Loading and closing cleaning basket**

Stack the loaded basket inserts back into the basket holder.

**Attention!** All basket inserts must strictly be replaced in the basket holder to be able to securely close the cleaning basket again. In doing so, it is not important whether all basket inserts are loaded.

Place the sieve lid (*Fig. 6.2.2.D*) in the top position.

Lock the cleaning basket with the basket locking.

**Placing cleaning basket in cleaning chamber**

**Attention!** Check that the basket locking (*Fig. 6.2.2.A*) is correctly locked before placing in the cleaning chamber.

When using third party baskets, check the bottom of the cleaning basket regularly for signs of wear due to the increased risk of wear (see *Chapter 9.2.3*).

Position the cleaning basket in the basket mounting (*Fig. 6.2.3.A*) on the floor of the cleaning chamber.

A ball gripper in the basket mounting fixes the cleaning basket in the basket mounting.

Check the correct fixing of the cleaning basket: When slightly pulled, the cleaning basket must remain connected to the basket mounting.

Check the seating of the cleaning basket: If the cleaning basket can be removed very easily, it was not fixed correctly. Position it again.

If the cleaning basket is no longer correctly mounted after longer use of the cleaning unit, check the wear on the toothing of the collar bushing (see Maintenance *Chapter 9.2.3*).

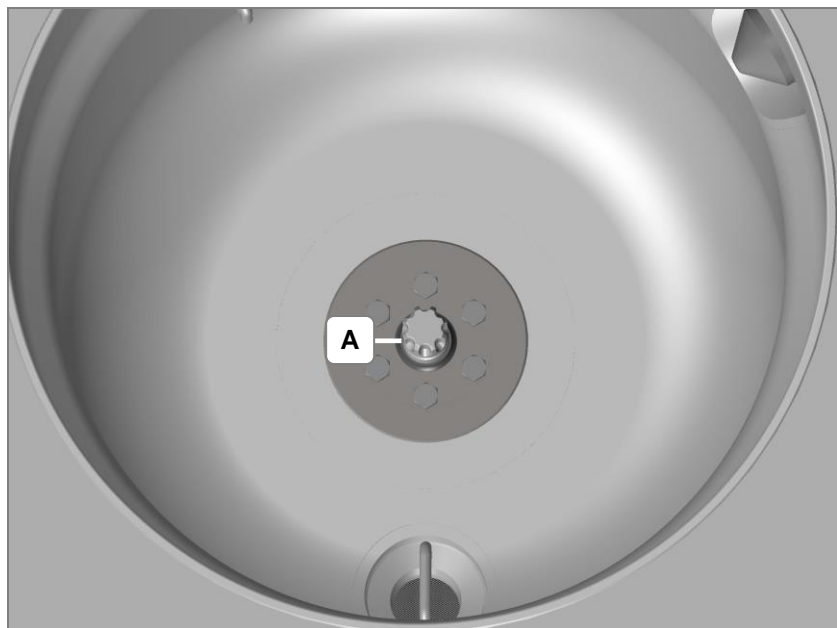

Fig. 6.2.3 Mounting for the cleaning basket

**Closing cleaning chamber**

Close the cover of the cleaning chamber. In doing so, the cover must audibly engage.



If the cover is not correctly sealed and therefore the cleaning chamber cannot be evacuated, an appropriate error message is shown on the display at the start of the cleaning process.



### 6.3 Selecting and starting cleaning program

**i** Three predefined cleaning programs are stored at the factory and are displayed in the program selection (Fig.6.3.1).

These are differentiated by the duration of individual cleaning and rinsing times and by different ultrasound modes:

- Standard** Cleaning program for normal soiling of the parts to be cleaned.
- Short** Cleaning program for normal soiling of the parts to be cleaned.
- Intensive** Cleaning program for normal soiling of the parts to be cleaned.

**i** Four special programs for particular applications are also stored (description Chap. 6.3.1). These are displayed in the *Visible Cleaning Programs* display setting and can be displayed in the program selection if required (see Chap. 7.1.5).

**Selecting cleaning program** Select the required cleaning program by navigating with **↑** / **↓**.

**Confirming selection** Confirm the selection with **OK**.



Fig. 6.3.1 Display *Program Select List* (home screen)

**Insert basket, close cover** The instruction to insert the basket and close the cover is shown on the display (Fig. 6.3.2).

If the cleaning basket has not yet been inserted, now load and insert the cleaning basket in the cleaning chamber (for procedure, see Chapter 6.2).

Close the cover of the cleaning chamber.



Fig. 6.3.2 Display *Insert basket and close lid*

**Starting cleaning program**

Press the now flashing Start/Pause button to start the cleaning program (Fig. 3.9.1.C).

The blue LED in the Start/Pause button lights.

**Safety test**

An automatic safety test is performed here during first start-up of the cleaning unit.

This safety test is also performed the first time any cleaning program is started after disconnection of the cleaning unit from the mains power supply (e.g. switching off using main switch).

The safety test takes approx. 1-2 minutes. The progress is shown on the display (Fig. 6.3.3).

The safety test can be aborted with the button **ESC**. The *Cancel safety test?* dialogue box is displayed.

The *Program Select List* display is shown when the button **OK** is pressed. The specified cleaning program is not started.

The safety test is continued by pressing the button **ESC**.



The safety test cannot be bypassed!

After completion of the cleaning program, this safety test is no longer performed for the next program start.



Fig. 6.3.3 Display *Safety test progress*

After performing the safety test, the cleaning unit automatically continues with the selected cleaning program.

**Initialisation phase**

After a short initialisation phase of 30 seconds, the cleaning unit starts filling the cleaning chamber.

This process is shown on the display (*Fig. 6.3.4*).

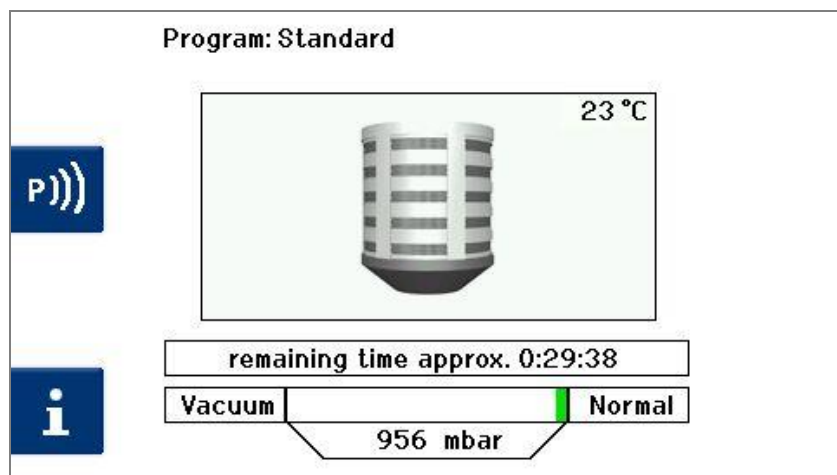

Fig. 6.3.4 Display *Status of the program progress*

**Start of the cleaning program**

After completion of the initialisation phase, the corresponding notification in the display is cleared and the cleaning program is started.

The remaining time until the end of the cleaning program is displayed.

**Initialising pager (optional accessory)**

If you have a pager, you can initialise this now (for description, see *Chapter 15 Appendix 2: Pager*).

**Progress display of the cleaning program**

The detailed progress of the cleaning program can be shown on the display (*Fig. 6.3.5*): Press the corresponding operating button **i** (*Fig.6.3.4*) to display this function.

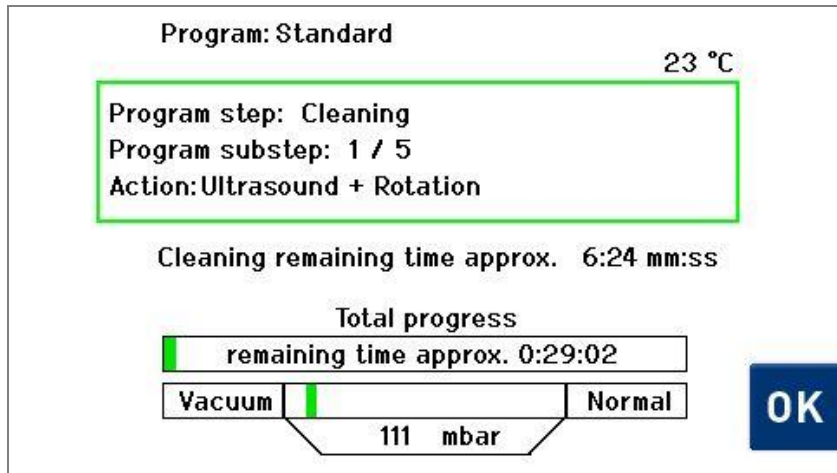

Fig. 6.3.5 Display *Detail information for the program progress*

### Cleaning program end

Press **OK** (Fig. 6.3.5) to return to the previous display.

The end of the cleaning program is notified by an ascending tone audible signal sequence.

The corresponding indication is shown on the display.

Press **OK** to confirm this notification and switch off the signal tone (Fig. 6.3.6).

The display for selection of the cleaning program (Fig. 6.3.1) is shown on the display again.



Fig. 6.3.6 Display *Program finished*

Now you can open the cover of the cleaning chamber and remove the cleaning basket.



**CAUTION**

Depending on the program duration, the cleaning chamber interior wall is still hot (<60 °C) and the cleaning basket is still warm (<45 °C) immediately after the program end.

If necessary let the cleaning basket cool down for some time in the cleaning chamber or wear gloves to remove the cleaning basket immediately.

### 6.3.1 Special Programs

In addition to the 3 predefined cleaning programs for all usual applications, 4 predefined programs for special applications are also available. These can be displayed as described in Chap. 7.1.5.

<b>Standard Drying</b>	Program for drying (complete drying step) in the event of cancellation of the cleaning program (cleaning basket wet).
<b>Movement holder V2 Prg</b>	Special cleaning program when using the W2V movement holder (without spinning).
<b>Epilamisation_Episuref</b>	Special program for epilamisation according to the method of the company Episuref (see <i>Chap. 16</i> ).
<b>After Drying</b>	Program for additional drying if the standard drying was not sufficient (cleaning basket moist).

## 6.4

### Interrupting / aborting cleaning program



Risk of injury from fast rotating cleaning basket!

Never open the cover of the cleaning chamber during the cleaning process!

Never reach into the rotating cleaning basket!

If required, cancel the cleaning program in a controlled way.

#### Interruption of the cleaning program

Press the Start / Pause operating button (*Fig. 3.9.1.C*) if the cleaning program has to be interrupted for any reason.

The display with the pause information (*Fig. 6.4.1*) is shown on the display.

Press the Start / Pause operating button (*Fig. 3.9.1.C*) if you would like to continue with the cleaning program.

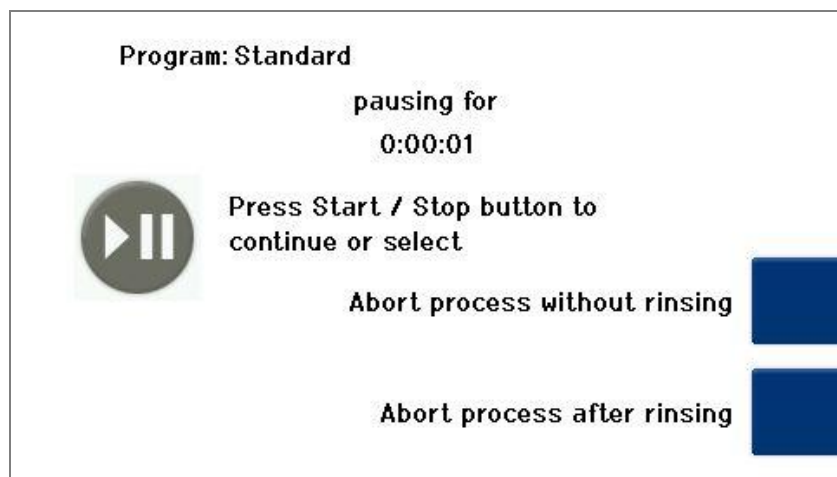

Fig. 6.4.1 Display *Pause*

#### Abortion of the cleaning program

If you would like to definitively abort the cleaning program, there is a selection option whether a rinsing process should still be performed or not.

Press *Abort process without rinsing* ■ or *Abort process after rinsing* ■ (*Fig. 6.4.1*).

In each case, drying of the parts takes place.

Information about the abortion of the cleaning program (*Fig. 6.4.2*) is displayed during the abortion process.

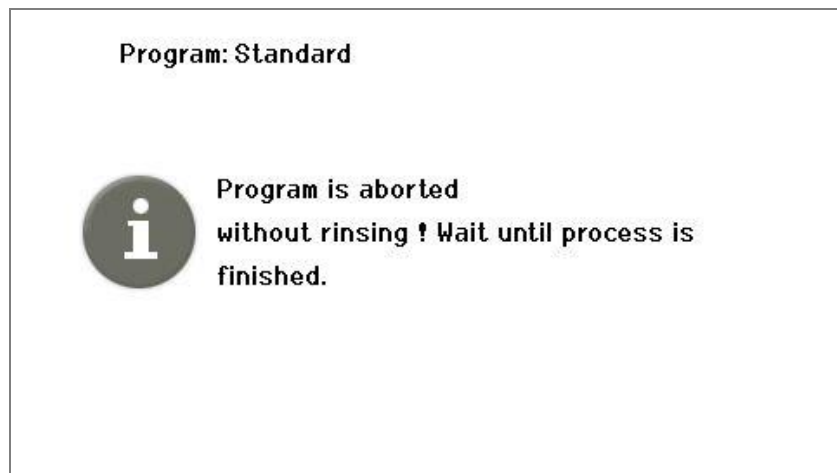
Fig. 6.4.2 Display *Program is aborted***Cleaning program end**

The end of the cleaning program is notified by an ascending tone audible signal sequence.

The corresponding indication is shown on the display.

Press **OK** (Fig. 6.4.3) to confirm this notification and switch off the signal tone.

The display for selection of the cleaning program (Fig. 6.3.1) is shown on the display again.

Fig. 6.4.3 Display *Program finished*

Now you can open the cover of the cleaning chamber and remove the cleaning basket.



Depending on the program duration, the cleaning chamber interior wall is still hot (<60 °C) and the cleaning basket is still warm (<45 °C) immediately after the program end.

If necessary let the cleaning basket cool down for some time in the cleaning chamber or wear gloves to remove the cleaning basket immediately.

## 7

## Settings



If an Administrator PIN has been stored by the user (*Chapter 7.1.2*), a request for the Admin PIN is shown on the display. Entries / changes for the unit settings and cleaning programs are not possible without input of the valid Administrator PIN.

## 7.1

## Unit Settings

It is possible to make various unit and program settings. These options are described in the following chapters.

The procedure for the operating steps starts in each case from the display *Program Select List* (Fig. 7.1.1) and then *Unit Settings* (Fig. 7.1.2).



Fig. 7.1.1 Display *Program Select List*

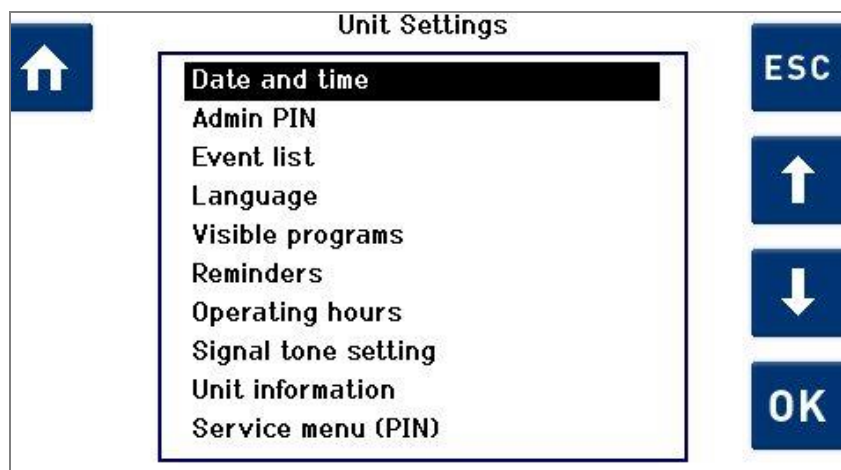

Fig. 7.1.2 Display *Unit Settings*



## 7.1.1 Date / Time





Date and time are not required for operation of the unit. However, in the event of unit faults, date and time are needed to be able to better evaluate faults.

We therefore recommend checking the factory settings and adjusting if necessary during the commissioning.







**Procedure** Starting from the display *Program Select List* (Fig.7.1.1):

1. Press .

The display *Unit Settings* (Fig. 7.1.2) is shown.

2. Using  /  select *Date and time* in the selection list and confirm with .

The *Date and time* (Fig. 7.1.1.1) display is shown.

3. Check whether the settings match the local time and date. If no changes are required, exit from the *Date and time* display using  or .
4. For changes, navigate using  /  to the relevant input fields (black background).
5. Adjust the values using  / .
6. Press  to apply the changes.

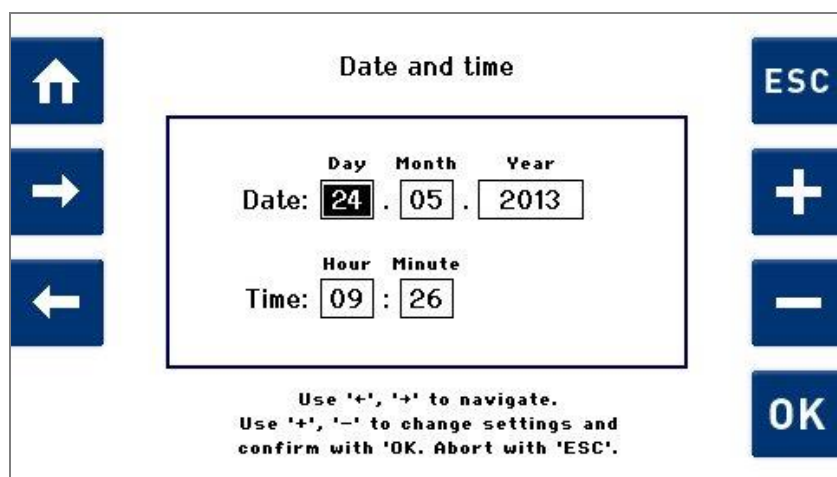

Fig. 7.1.1.1 Display *Date and time*

## 7.1.2 Administrator PIN



The allocation of an Administrator PIN is used to only enable access to the unit and program settings using an enabling PIN. An Administrator PIN is allocated by the user. The PIN request is deactivated in the factory settings (*Off*): The cleaning unit can be operated without restriction with the factory settings.

### PIN activation procedure

Proceed as follows to allocate an Administrator PIN:

Starting from the display *Program Select List*):

1. Press

The display *Unit Settings* (Fig. 7.1.2) is shown.

2. Using / select *Admin PIN* in the selection list and confirm the selection with .

The *Admin PIN* (Fig. 7.1.2.1) display is shown.

3. Press to allocate an Administrator PIN.

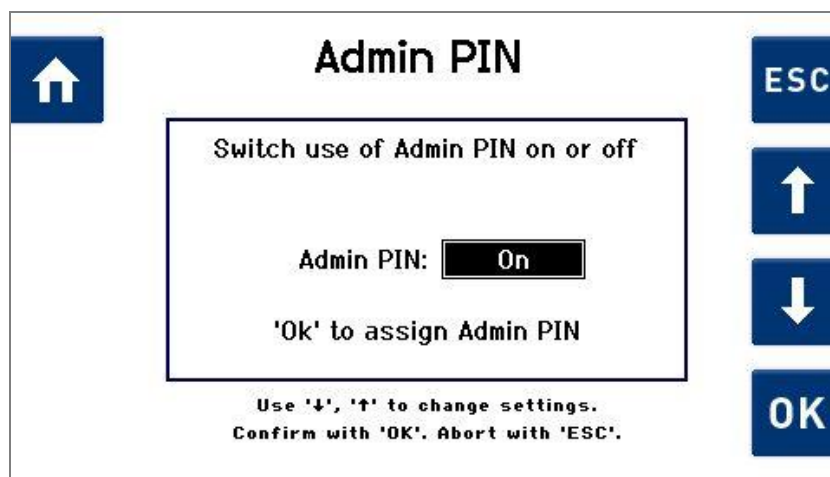

Fig. 7.1.2.1 Selection field for activating / deactivating the Admin PIN

The *Admin PIN* (Fig. 7.1.2.2) display is shown.

The Administrator PIN must consist of 4 digits.

4. Navigate within the line of the digit selection using / .
5. Press to apply the selected digit.
6. Press to save the specified 4-digit Administrator PIN.

A display (Fig. 7.1.2.3) is shown for confirmation of the Admin PIN by inputting it again.

7. Enter the same number again as previously described and press **OK**.

Press **ESC** or **↑** to exit from this display without changes.



Fig. 7.1.2.2 Display *Assign Admin PIN*

The Administrator PIN has now been set. A dialogue box requesting the Admin PIN will be displayed the next time *Program Settings* or *Unit Settings* is called. Further operation is only possible with entry of the valid Admin PIN.

If you have forgotten the PIN, press **i** (Fig. 7.1.2.3) and follow the instructions.



Fig. 7.1.2.3 Display *Enter PIN*

### Procedure for deactivating Admin PIN

Proceed as for the Admin PIN activation procedure.

After input of the previously set Admin PIN, select the setting *Off* in the display (Fig. 7.1.2.1) using **↑** / **↓** and confirm the selection with **OK**.

### 7.1.3 Event List



The *Event List* is not needed for normal operation of the cleaning unit. In the event of a fault, the customer can look up which fault it is in the *Event List*. In contrast to the display of any fault or warning message during operation, the entries stored here contain additional information.

The *Event List* contains entries about faults, warnings and information (e.g. performed software updates).

For fault clearance, see Chapter 11.3 *Fault clearance by user*. The entries also provide fault descriptions for technical support or the on-site service technician.

#### Procedure for displaying the event list

In the event of a fault, invoke the *Event List* to obtain further information for the fault and fault clearance. Proceed as follows:

Starting from the display *Program Select List*.

1. Press

The display *Unit Settings* (Fig. 7.1.2) is shown.

2. Using / select *Event List* in the selection list and confirm the selection with .

The *Event List* (Fig. 7.1.3.1) display is shown.

3. Navigate using / in the *Event List* to go through the saved events.

The entries can only be deleted by the Service personnel.



Select Entry ( 13 )		
No.	Description	Date
	7 Program not finished	22.05.2013
	66 Explosion protection	21.05.2013
	16 Program not finished	21.05.2013
	98 Tank overfilled	21.05.2013
	2 Program not finished	21.05.2013
	84 Tank overfilled	21.05.2013
	6 Program not finished	21.05.2013

'↓', '↑' to select event. 'i' show details.  
Back with 'ESC'.

Fig. 7.1.3.1 Display *Event List*

**Procedure for displaying details**

The detailed information view of an event contains important additional information for more precise assessment of the fault.

1. Navigate using  /  in the *Event List* and press  to retrieve further information about the respective entries.

The following display (*Fig. 7.1.3.2*) is shown.

2. Press  to exit from the detail view.



Fig. 7.1.3.2 Display *detailed information view*

## 7.1.4 Changing user language



The user language specified during the first start-up can be changed at any later time.

**Procedure** Starting from the display *Program Select List*):

1. Press

The display *Unit Settings* (Fig. 7.1.2) is shown.

2. Using / select *Set language* in the selection list and confirm with .

The *Set language* (Fig. 7.1.4.1) display is shown.

3. Select the required language using / .
4. Press to apply the changes.

Press or to exit from this display without changes.



Fig. 7.1.4.1 Display *Set language*

## 7.1.5 Visible cleaning programs



 The *Visible Cleaning Programs* setting makes it possible to display and hide programs in the *Program Select List* display.

If needed, only "required" cleaning programs can be displayed.





**Procedure** Starting from the display *Program Select List*):

1. Press .

The display *Unit Settings* (Fig. 7.1.2) is shown.

2. Using  /  select *Visible Cleaning Programs* in the selection list and confirm with .

The display *Visible Cleaning Programs* (Fig. 7.1.5.1) is shown.

3. Using  / , select the program which should be displayed or hidden.
4. Press  to activate or deactivate the selection field. Activated programs are marked with a checkmark.
5. Proceed in the same way if other programs should be hidden or displayed.
6. Press  to apply the changes.



Press  or  to exit from this display without changes.



Fig. 7.1.5.1 Display *Visible Cleaning Programs*

## 7.1.6 Reminders



The *Reminders* menu item enables the activation of reminders for exchange of media and the setting of a general reminder (e.g. change activated carbon filter).

### Procedure Reminders Call

Starting from the display *Program Selection*:

1. Press

The *Machine Settings* (Fig. 7.1.2) display is shown.

2. Using / select Reminders in the selection list and confirm with .

The display *Reminders* (Fig. 7.1.6.1) is shown.

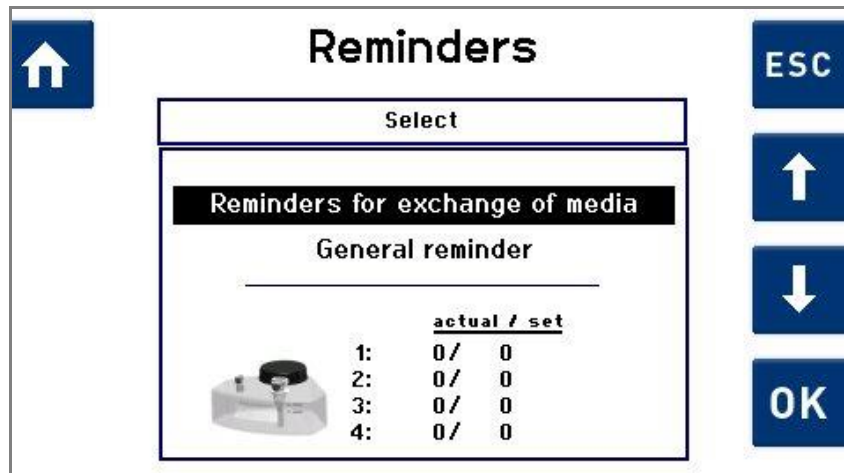

Fig. 7.1.6.1 Display *Reminders for exchange of media*

### **Reminders for exchange of media**



The menu item *Reminders for exchange of media* enables the activation of reminders for an exchange of media and setting of the reminder intervals.

3. Using / select *Reminders for exchange of media* in the selection list and confirm with .  
If you would like to exit from this display, press or .



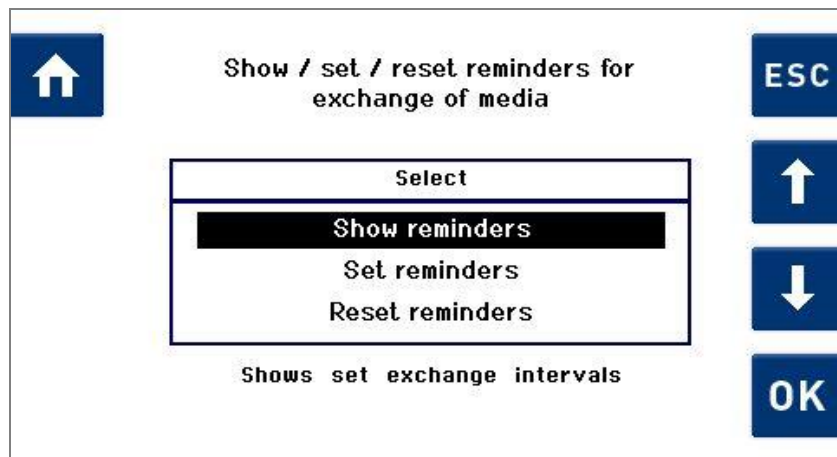

Fig. 7.1.6.2 Display Reminders for exchange of media

### Procedure for *showing* reminders

Using **↑** / **↓**, select *Show reminders* in the selection list and confirm with **OK**.

The following display (Fig. 7.1.6.3) is shown.

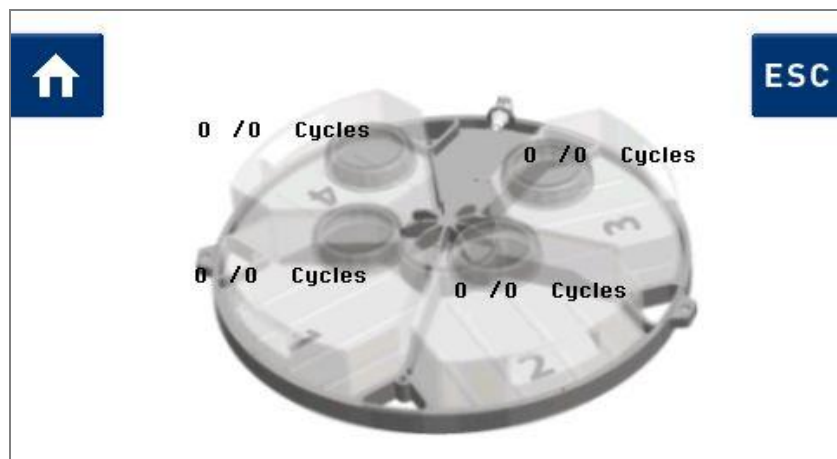

Fig. 7.1.6.3 Display Show reminders



As soon as a specific value is set after the forward slash, the unit - depending on the setting - counts either the cleaning cycles or the elapsed days since setting this value for the respective media tank.

### Procedure Set Reminders

- Using **↑** / **↓**, in the selection list (Fig. 7.1.6.1), select *Set reminders* and confirm with **OK**.

The *Set reminders for exchange of media* (Fig. 7.1.6.4) display is shown.

- Using **←** / **→**, select between the input value and the unit *Cycles / Days* (see Fig. 7.1.6.5).
- Press **+** / **-** to set the input value or to change the unit (*Cycles / Days*).
- Press **OK** to save the settings.
- Press **↑** or **ESC** to exit from the settings without saving.

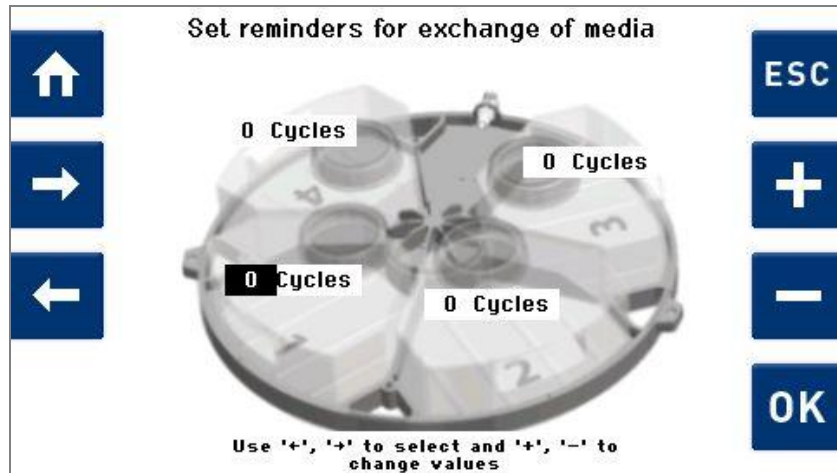

Fig. 7.1.6.4 Display *Set reminders for exchange of media*

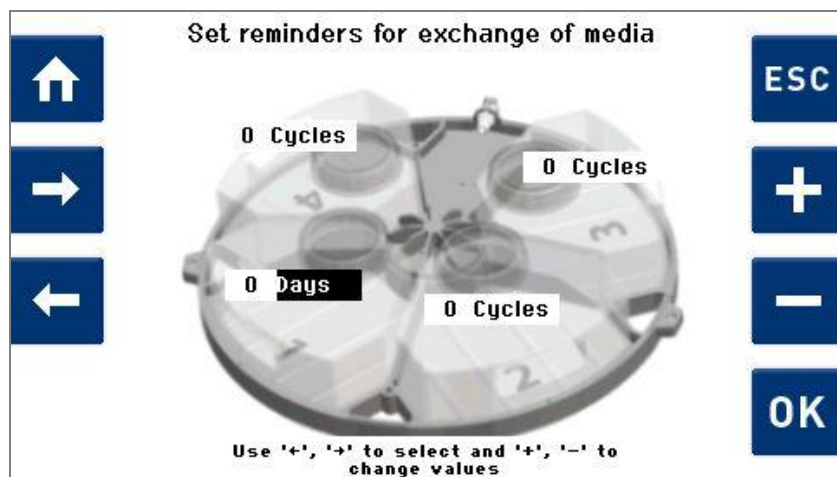

Fig. 7.1.6.5 Display *Set Unit*

**Procedure for  
resetting reminders**

1. Using **↑** / **↓**, in the selection list (Fig. 7.1.6.1), select *Reset reminders* and confirm with **OK**.

The *Reset reminders for exchange of media* (Fig. 7.1.6.6) display is shown.

2. Press **OK** to reset the counted cycles or days individually or completely to 0.

The counting starts again from 0.

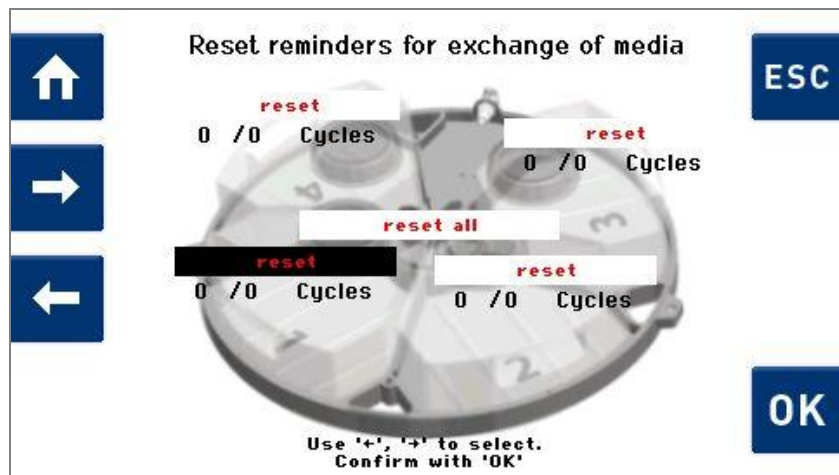

Fig. 7.1.6.6 Display *Reset reminders for exchange of media*

### Reminder for media change

If the set input value is reached, the *Change Medium!* (Fig. 7.1.6.7) display is shown after program execution. The relevant media tank is marked with a warning symbol.

Now perform the media change.

After changing the media, press .

All counted *cycles* or *days* are reset to 0.

If you would like to perform the media change at a later time, press  to be reminded again after the next program run.

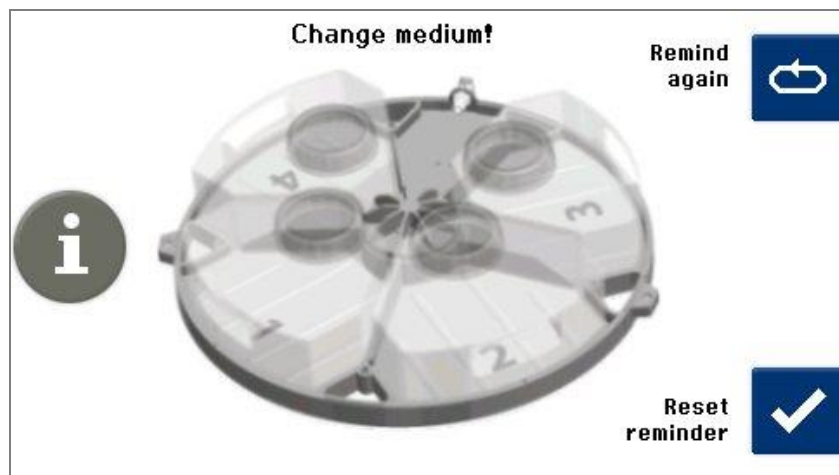

Fig. 7.1.6.7 Display *Reminder for exchange of media*

**General reminder****Procedure Set Reminders**

The menu item *General reminder* enables the activation of any reminder and the specification of the reminder interval.

Starting from the display *Program Selection*:

1. Press

The display *Machine Settings* (Fig. 7.1.2) is shown.

2. Using / select Reminders in the selection list and confirm with .

The display *Reminders* (Fig. 7.1.6.8) is shown.

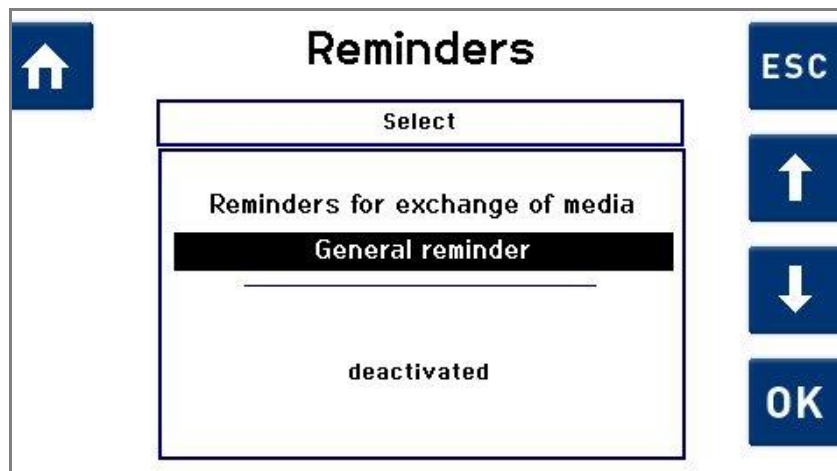

Fig. 7.1.6.8 Display *Reminders* (*General reminder deactivated*)

Starting from the display *Reminders*:

3. Using / select *General reminder* in the selection list and confirm with .

The following screen is displayed: *Assign a description to the general reminder (max. 30 characters)* Fig. 7.1.6.9

4. Navigate with / and / . Select character with to save and proceed.

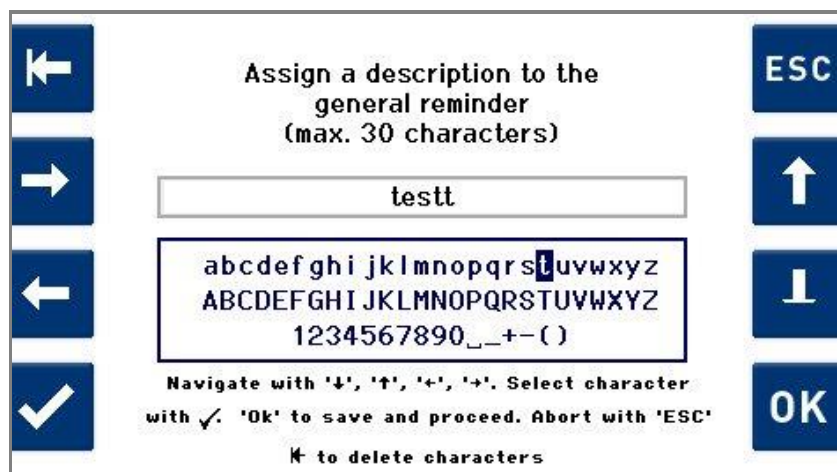

Fig. 7.1.6.9 Display description *General Reminder*

5. Press **OK** to save the settings.
6. Press **↑** or **ESC** to exit from the settings without saving.

The reminder description (example *test* Fig. 7.1.6.9) is shown in the reminder display for setting the reminder interval.

**Setting the reminder interval**

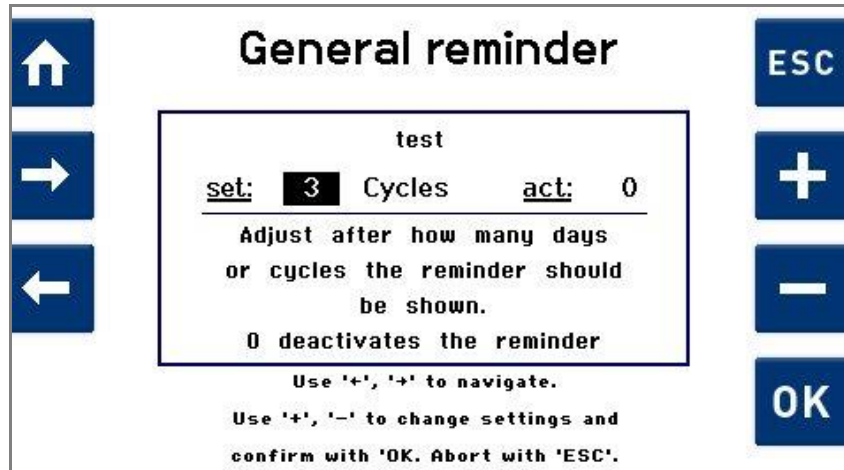

Fig. 7.1.6.10 Display for setting reminder interval

7. Using **←** / **→**, select between the input value and the unit *Cycles / Days* (see Fig. 7.1.6.10).
8. Press **+** / **-**, to adjust the input value or to change the unit (*Cycles / Days*).
9. Press **OK** to save the settings.
10. Press **↑** or **ESC** to exit from the settings without saving.

After the specified interval (*Cycles / Days*) has elapsed, the Reminder display (example *test* Fig. 7.1.6.11) is shown.

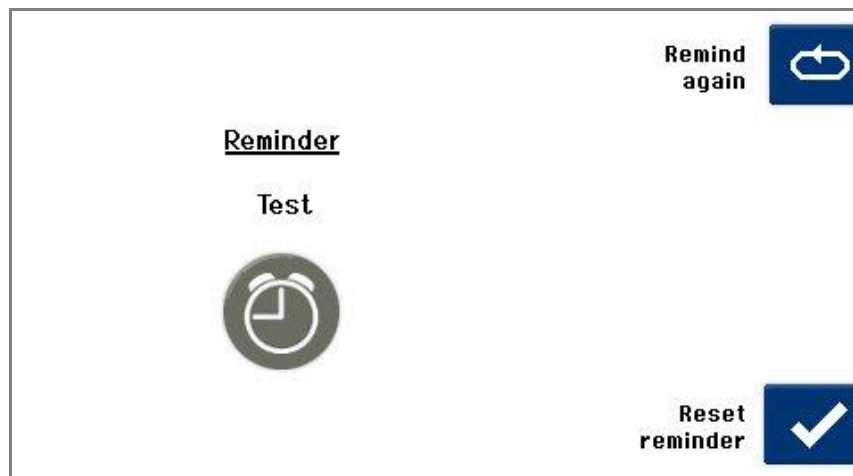

Fig. 7.1.6.11 Display *Reminder*

11. Press **↺** to be reminded again.
  12. Press **✓** to reset the counted cycles / days to 0.
- The counting starts again from 0.

## 7.1.7 Display Operating Hours

**i** The *Operating Hours* menu item enables a view of the usage time to date of the unit and individual components.

The usage time is shown in cycles or hours and minutes.



Every component required for the cleaning process is shown separately with the respective usage time.

Only completely executed cycles are added.





**Procedure** Starting from the display *Program Select List*.

1. Press .

The display *Unit Settings* (Fig. 7.1.2) is shown.

2. Using  /  select *Operating Hours* in the selection list and confirm with .

The *Operating Hours* display is shown (Fig. 7.1.7.1).

3. Use  /  to be able to see all entries in the list.
4. Press  or  to exit from this display.

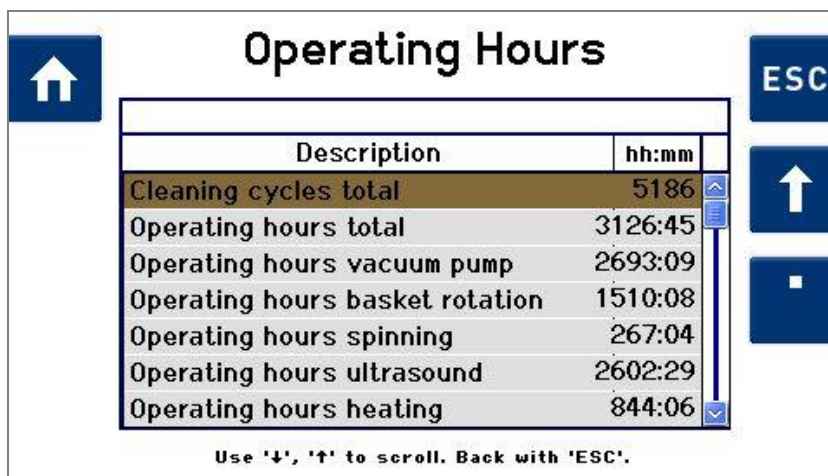

Description	hh:mm
Cleaning cycles total	5186
Operating hours total	3126:45
Operating hours vacuum pump	2693:09
Operating hours basket rotation	1510:08
Operating hours spinning	267:04
Operating hours ultrasound	2602:29
Operating hours heating	844:06

Use '↓', '↑' to scroll. Back with 'ESC'.

Fig. 7.1.8.1 Display *Operating Hours*

## 7.1.8 Setting signal tone for program end





The *Signal tone setting* menu item enables the activation of a signal tone at the end of any program run.



**Procedure** Starting from the display *Program Select List*:

1. Press .

The display *Unit Settings* (Fig. 7.1.2) is shown.

2. Using  / , select *Signal tone setting* in the selection list and confirm with .

The *Signal tone setting* (Fig. 7.1.8.1) display is shown.

3. Select using  /  whether a signal tone (*On*) or no signal tone (*Off*) should sound at the end of the cleaning program.
4. Press  to confirm the input.

Press  to exit from this display without changes.

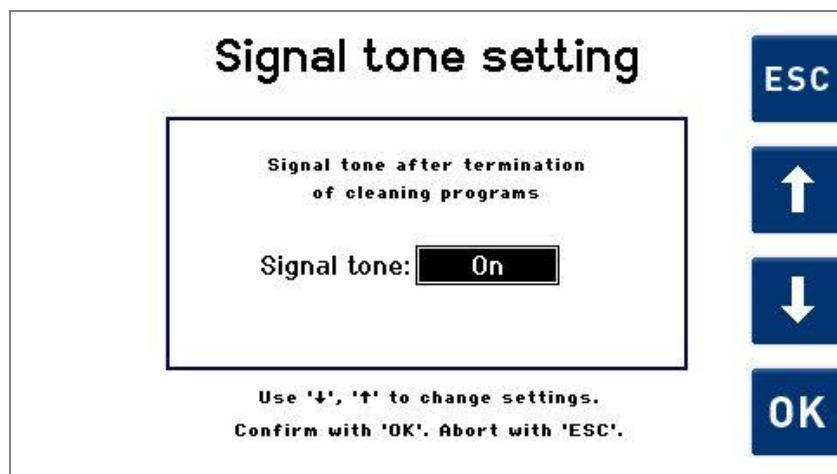

Fig. 7.1.9.1 Display *Signal tone setting*

## 7.2

### Creating your own cleaning programs

It is possible to create up to 13 additional cleaning programs of your own. There are the following options for creating cleaning programs in accordance with your own requirements:

- Create new cleaning program (*Chapter 7.2.1*).  
Recommended procedure if a program should be created with completely new parameters.
- Create new cleaning program based on a copy of an existing cleaning program (*Chapter 7.2.2*). Recommended procedure if an already existing program should be copied and also made available with a few parameter changes.
- Change existing cleaning program (*Chapter 7.2.3*).  
Recommended procedure if various parameters of an existing program should be modified.

The predefined cleaning programs stored in the cleaning machine at the factory cannot be modified or deleted.

Programs you create yourself can be copied, modified or deleted at any time.

It is also possible to delete (your own) existing cleaning programs (*Chapter 7.2.4*).



Factory predefined cleaning programs are shown on the display with a blue background. Your own cleaning programs have a green background. The respective selected cursor field has a brown background.

**Procedure** In the *Program Select List* (*Fig. 7.2.1*), select *Create / modify / delete Programs* using  /  and confirm the selection with **OK**.



Fig. 7.2.1 Display *Program Select List*

The display (*Fig. 7.2.1.1*) is shown: *Modify / Create programs*.



## 7.2.1

**Create new cleaning program**

Proceed starting from the display *Modify / Create Programs*.



Fig. 7.2.1.1 Display *Modify / Create Programs*

Using **↑** / **↓**, select *Create new program* in the selection list and confirm with **OK** (Fig. 7.2.1.1).

The *Enter a program name* (Fig. 7.2.1.2) display is shown.

**Naming new program**

Navigate within any line of the character selection using **←** / **→**.

Using **↑** / **↓**, you can navigate between the 3 lines.

Using the button **←**, you can delete already entered characters.

Press **✓** to apply the selected character.

To save the entered program name and continue with setting the program parameters, press **OK**.

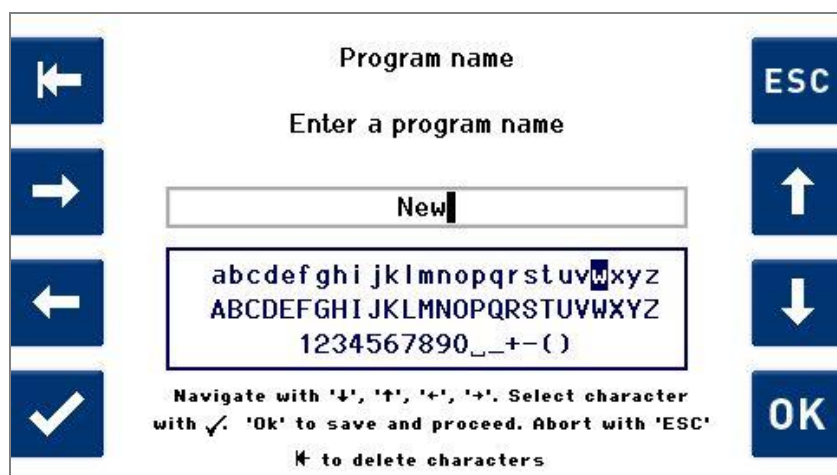

Fig. 7.2.1.2 *Enter a program name*

### Program Parameters Cleaning set / change

First, the display with the program parameters from the process step *Clean* (Fig. 7.2.1.3) is shown. The already preset program parameters are based on standard cleaning processes values. You can change the preset values individually (or keep them).

Program:	New	
Duration:	0:29:38h:m:s	
<b>Clean</b>		
Duration:	5 min:	0 sec
Ultrasound:	40 khz	90 %
Movement:	Rotation	medium
5U/min		
Spin:	1000 U/min	0 min: 30 sec
		Rinse1

Fig. 7.2.1.3 Display Process step *Clean*

Navigate between the input fields using **←** / **→**.

Press **+** / **-** to change the preset values.

To save the settings and continue to the next process step (1st rinse step), press *Rinse 1* **→**.

The *Rinse 1* (Fig. 7.2.1.4) display is shown.



If you would like to exit from this display without changes and call the *Program Select List* display, press **↑**.

### Program Parameters Rinsing set / change

For setting the *Rinse 1* process parameters, proceed in the same way as previously described for setting the *Cleaning* process parameters.

Program:	New	
Duration:	0:29:38h:m:s	
<b>Rinse1</b>		
Duration:	2 min:	0 sec
Ultrasound:	80 khz	90 %
Movement:	Rotation	medium
5U/min		
Spin:	1000 U/min	0 min: 30 sec
Clean	Rinse2	

Fig. 7.2.1.4 Display Process step *Rinse 1*

After making the changes, press *Rinse 2*  to reach the display for the 2nd rinsing step and proceed there in the same way. Press  if you would like to return to the previous display.



Then proceed in the same way with the 3rd rinsing step and the drying step.

After you have changed the values of the program parameters, press  to return to the *Program Select List* display.

A query for saving the settings made is displayed first (see Fig. 7.2.1.5).



Fig. 7.2.1.5 Display *Save changes*

Using  /  select the required action from the selection list and confirm with .

Using the *Reject changes* selection, you return to the *Program Select List* display without saving the settings made.

Using the *Abort* selection, you return to the previous display.

## 7.2.2

### Create cleaning program from copy

On the display *Modify / Create Programs* (Fig. 7.2.1.1), select *Create new program* using  /  and confirm with .

The display *New program from copy* with the already existing cleaning programs (Fig. 7.2.2.1) is shown.

#### Selecting program to be modified

Using  / , select the cleaning program which should be copied and modified (e.g. *Standard*).

Confirm the selection with .

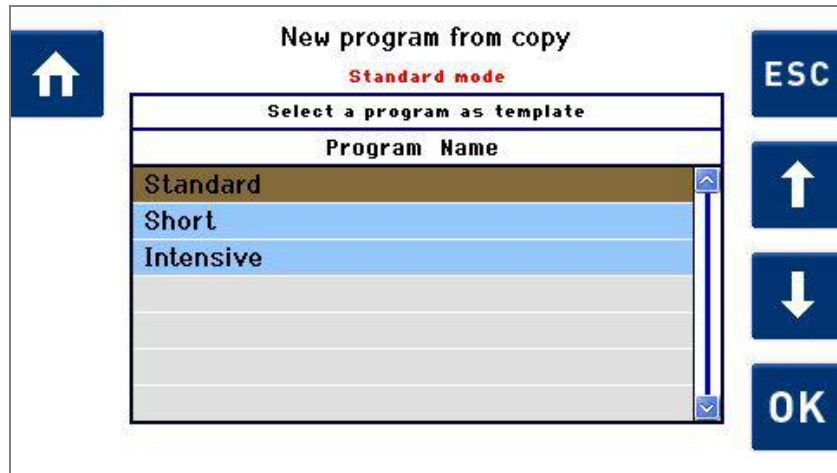
Fig. 7.2.2.1 Display *new program from copy*

### Naming new program

After selection of the cleaning program to be copied, the *Program name* display (Fig. 7.2.2.2) is shown.

In the field for the program name, the original program name with a number e.g. *\_0* is initially specified. The name can be changed individually as described in *Chapter 7.2.1*.

To save the program name and continue with setting the program parameters, press **OK**.

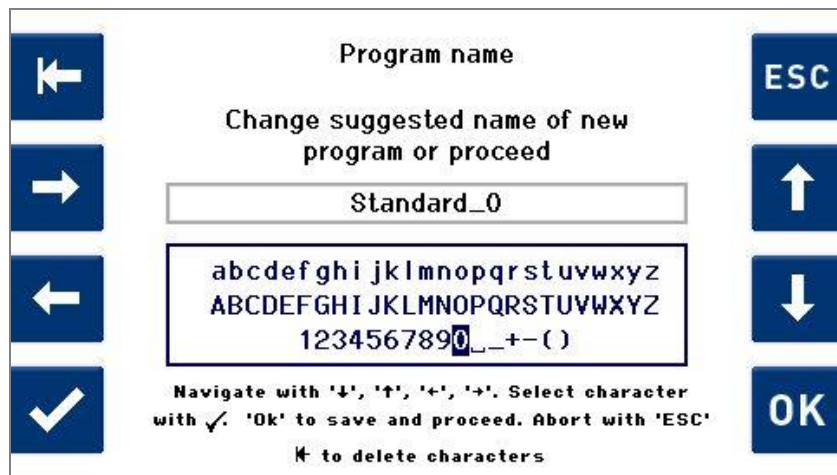
Fig. 7.2.2.2 Display *Program Name*

### Editing program parameters

After entry of the program name, the display with the program parameters of the process step *Clean* (Fig. 7.2.1.3) is first shown.

The already existing program parameters of the copied cleaning program can now be adjusted individually.

Proceed as described in *Chapter 7.2.1*.

## 7.2.3 Modifying existing cleaning program

**i** The predefined cleaning programs stored in the cleaning machine at the factory cannot be modified.

Programs you create yourself can be copied, modified or deleted at any time.

In order to change a factory predefined cleaning program, it must first be saved as a copy (*Chap. 7.2.2*).

If there is still no own cleaning program apart from the standard programs available, the message that no modifiable program has been found is shown on the display when selecting *Modify existing program*.

**Procedure** On the display *Modify / Create Programs* (*Fig. 7.2.1.1*), select *Modify existing program* using **↑** / **↓** and confirm with **OK**.

The display *Modify program* with the already existing cleaning programs (*Fig. 7.2.3.1*) is shown.

**Selecting program to be modified** Using **↑** / **↓**, select the cleaning program which should be *modified* (in the example *Standard\_0*) (*Fig. 7.2.3.1*).

Confirm the selection with **OK**.



Fig. 7.2.3.1 Display *Modify Program*

**Rename program if necessary** After selection of the cleaning program to be modified, the *Program name* display (*Fig. 7.2.2.2*) is shown.

The name can be changed individually or retained as described in *Chapter 7.2.1*.

To save the program name and continue with setting the program parameters, press **OK**.

**Editing program parameters** First, the display with the program parameters from the process step *Clean* (*Fig. 7.2.1.3*) is shown.

The already existing program parameters of the cleaning program to be modified can now be adjusted (overwritten) individually.

## 7.2.4 Delete cleaning program



The predefined cleaning programs stored in the cleaning machine at the factory cannot be deleted.

Programs you create yourself can be deleted at any time.

### Procedure

On the display *Modify / Create Programs* (Fig. 7.2.1.1), select *Delete existing program* using / and confirm with .

### Selecting program to be deleted

Using / , select the cleaning program which should be deleted (in the example *Standard\_0*) (Fig. 7.2.4.1).

Confirm the selection with .

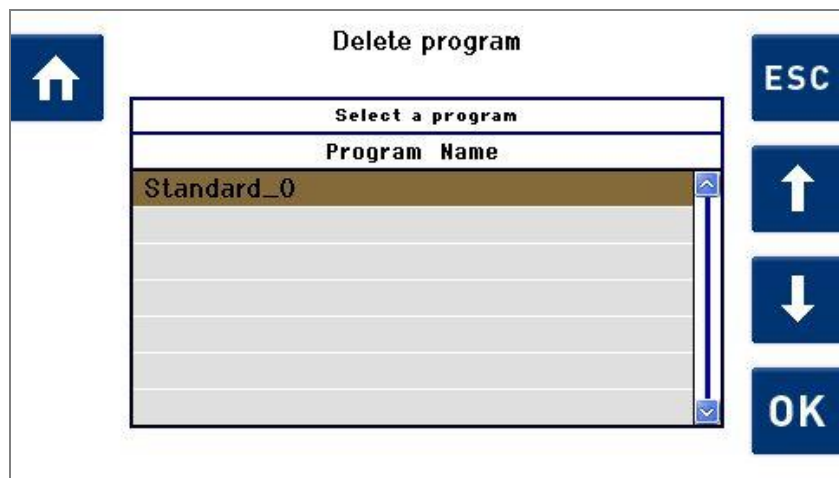

Fig. 7.2.4.1 Display *Delete program*

A display with the query whether the selected program should really be deleted is shown.

Press to confirm the "delete program" command.

Press if the command should be discarded.

For both actions, the display *Delete program* is reached afterwards. It is possible to delete further programs or return to the *Program Select List* display .

## 8

**Media (cleaning / rinsing solutions)**

Only media with flashpoint of at least ( $\geq$ ) 12 °C are generally permissible in the Elmasolvex®VA.

Observe the information concerning this in the safety data sheet of the medium / solvent.

In the case of doubt, contact your authorised dealer or the manufacturer.

Maximum one day's requirement of the solvents used is permitted to be stored in the surroundings of the cleaning unit at a minimum distance of 3 m from the cleaning unit.



**ATTENTION**

**Observe material compatibility**

**Media-contacting surfaces in the unit**

When selecting cleaning and rinsing media, pay attention to their compatibility with the stainless steel (1.4301) ultrasonic bath and other stainless steel small surfaces (1.4305, 1.4310, 1.4404) and the other materials of the unit coming into contact with the media. The other plastic and elastomer materials coming into contact with the media in vapour or liquid form are:

- Polytetrafluorethylene (PTFE)
- Polyetheretherketone (PEEK)
- Polysulphone (PSU)
- Polyphenylene sulphide (PPS)
- Polyoxymethylene (POM)
- Polypropylene (PP)
- Polyamide 12 (PA 12) for the media tanks
- Polyethylene (PE)
- Peroxide or oxygen cross-linked EPDM and NBR for static seals so that their swelling in aliphatic hydrocarbons is safe.
- FPM
- FFPM.

Also the activated carbons in the outlet filters.



**ATTENTION**

**Safety instructions**

Only media which are compatible in vapour or liquid form with these materials can be considered for any application.

Also observe the safety instructions (e.g. goggles, gloves, risk and safety statements) specified by the manufacturer or supplier for handling the cleaning and rinsing media used.

In the case of doubt, contact the manufacturer or supplier.

**Exclusion of liability**

Elma shall not be liable for defects for the Elmasolvex®VA unit in the case of damage caused by non-observance of the restrictions specified in *Chapter 8!*

## 8.1

### Recommended media



Elma provides suitable solvent-based cleaning ("elma wf pro"), rinsing ("elma suprol pro") and relubrication media ("elma unimix") from its own development and manufacture. Ask your dealer about these.



#### ATTENTION

The unit is always suitable for cleaning and rinsing media which are based on

1. aliphatic C8-C11 hydrocarbons  
(Exceptions: Aromatic hydrocarbons such as toluene (methylbenzene), xylene (o-, m-, or p-dimethylbenzene) and mesitylene (1,3,5-trimethylbenzene) and hydrocarbon mixtures with more than 25% content of aromatic hydrocarbons)
2. C3 or higher alkyl compounds  
(Exceptions: Ethers, particularly mono, di and tripropylene glycol methyl ether (PM, DPM and TPM))
3. and meet the flashpoint limitation  $FP \geq 12 \text{ }^\circ\text{C}$ .

The upper limit of the boiling range of rinsing media should not exceed  $170 \text{ }^\circ\text{C}$  for successful drying (only use volatile rinsing media).

#### Instructions for the above-mentioned recommended media:

(1) The upper limit of the boiling range of rinsing media should not exceed  $170 \text{ }^\circ\text{C}$  at normal pressure for successful drying (use sufficient volatile rinsing media at least in the last rinsing step).

(2) If the boiling range of any cleaning or rinsing medium undercuts the lower limit of  $100 \text{ }^\circ\text{C}$  at normal pressure, the heating of the medium combined with long-lasting ( $> 3$  minutes) ultrasound impact at full power can result in coming close to the (lower under vacuum) boiling point of such a medium.

The "Warning 211, Evacuation gradient too small" would be displayed in such a case as the required vacuum in the working chamber in the spatial area above the medium filling level would heat to  $> 30 \text{ }^\circ\text{C}$  at which the vacuum for already almost boiling media will no longer be reached quickly enough. A cooling down pause interrupting the operation of the unit or a change to medium cooled down to  $T < 30 \text{ }^\circ\text{C}$  in the storage tank will then be required.

For example, this concerns operation of the unit with isopropyl alcohol (isopropanol, 2-propanol, IPA).

Media whose boiling range at the lower limit even undercuts  $80 \text{ }^\circ\text{C}$  at normal pressure require media temperatures  $< 25 \text{ }^\circ\text{C}$  in the storage tank for fault-free unit operation.



## 8.2

### Technical limitations



ATTENTION

Aqueous media should not be used. Risk of unit damage!

Only solvent-based media are generally recommended for the Elmasolvex®VA unit. The unit is functionally not suitable for aqueous media, irrespective whether pH-neutral, pH-acidic or pH-alkaline.

In particular, it is not designed for foaming, aqueous cleaning media and does not have any drying suitable for parts wet with rinsing water.

Due to the filling level sensor, generally only liquid media with a relative dielectric constant (DK) of  $DK \geq 2.0$  (20 °C, 100 kHz) are permitted.

## 8.3

### Limitations for solvent-based media

#### 8.3.1

#### Flammable, solvent-based media



DANGER

Among the mostly flammable, solvent-based media, those with a flashpoint greater than or equal to 12 °C are permitted in the unit. Other media on request

Therefore, note the flashpoint specification in the safety data sheet of your intended cleaning and rinsing media.

#### 8.3.2

#### Non-flammable, solvent-based media



ATTENTION

In the case of intended permanent use with fluorinated, non-flammable solvents (e.g. epilamisation), seals made of the fluoroplastic elastomers FPM, FFPM may have to be replaced previously (see materials mentioned above).

In the case of using the unit for epilamisation with epilamisation additives / concentrates dissolved in isopropyl alcohol (isopropanol, 2-propanol, IPA), no modifications have to be made to the unit in advance.

The instructions given in *Chapter 8.1* for the lower limit of the boiling range must also be observed for units with default settings for the user's own and standard programs also used with the media used for epilamisation and epilam coating removal.

The explosion safety requirements are not necessary in the case of exclusive use of fluorinated, non-flammable solvents.

Use with chlorinated or brominated solvents is not recommended; these require checking on request in advance and possibly the replacement of seals.

### 8.3.3

#### Environmental compatibility



### Environmental hazard from solvent-based media

The cleaning and rinsing media based on hydrocarbons are not water-miscible and mostly hazardous for the environment. Also note the markings with warnings and pictograms and the information in the safety data sheet of your intended cleaning and rinsing media. This is applicable to a smaller extent for media based on alkoxy compounds.

The marking must be observed both for handling the solvent-based media as well as for their disposal.



"elma wf pro" is classified as environmentally hazardous according to R51 and R53 and therefore has an environmental hazard pictogram while "elma suprol pro" and "elma unimix" are only classified with R52 and R53 and therefore do not have any environmental hazard pictogram.

## 9 Care and maintenance tasks

The actions described in this chapter must be performed by the user.



**DANGER**

Always unplug the mains plug before care and maintenance work.

Order the required components and consumable materials from your dealer in good time.

### 9.1 Daily maintenance actions

#### 9.1.1 Filling level check of the media tanks

**Recommended interval** Before every start of any cleaning program

**Inspection criteria** Visually inspect whether the filling level of the different media tanks is in the range between the Min and Max markings (Fig. 9.1.1.1.D).

**Procedure** Adjust the filling level accordingly if required.

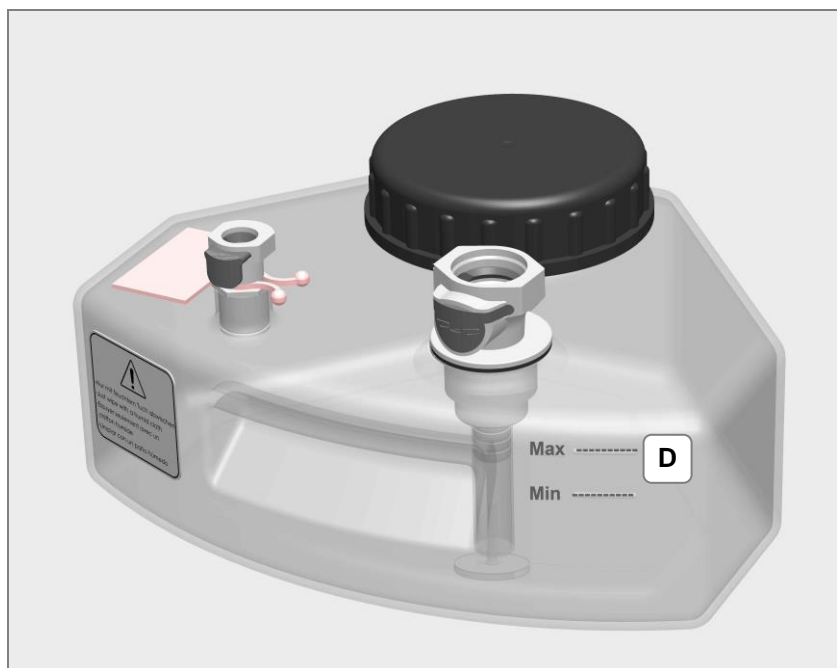



Fig. 9.1.1.1 Media tanks filling level markings

## 9.1.2 Cleaning the cleaning chamber

- Recommended interval** Before every start of the cleaning program.
- Inspection criteria** Visually inspect the cleaning chamber for residues and soiling. In doing so, particularly check the area of the heater (*Fig. 9.1.4.1.E*) for adhesions.
-  Due to the increased surface temperatures in this area, discolouration and deposits can increasingly occur.
- Procedure** If required, clean the cleaning chamber with a cloth moistened with alcohol (e.g. IPA).

## 9.1.3 Cleaning of the drain sieve

- Recommended interval** Before every start of the cleaning program.
- Inspection criteria** Visually inspect the sieve for residues and soiling. The sieve meshes must be clean and freely permeable.
- Procedure** Unscrew the drain sieve (*Fig. 9.1.4.1.D*) anticlockwise out of the drain groove.
- Clean the sieve meshes carefully, e.g. with compressed air or a suitable brush.
- Afterwards, screw the drain sieve tightly back into the screw connection of the drain groove. Ensure that the bracket of the drain sieve does not contact the cleaning basket.
-  **ATTENTION** Never operate the cleaning unit without sieve insert. Risk of damage in the cleaning unit!

## 9.1.4 Cleaning the filling level sensors

- Recommended interval** Daily
- Inspection criteria** Visually inspect the surfaces of the filling level sensors and the guard bar for soiling or damage (*Fig. 9.1.4.1.A/B/C*).
- Procedure** In the case of visible soiling, clean the components carefully with a moist cloth and a suitable cleaning agent (e.g. with your rinsing medium).
- In the case of recognisable damage to the sensors, the cleaning unit must no longer be operated. Contact the manufacturer.

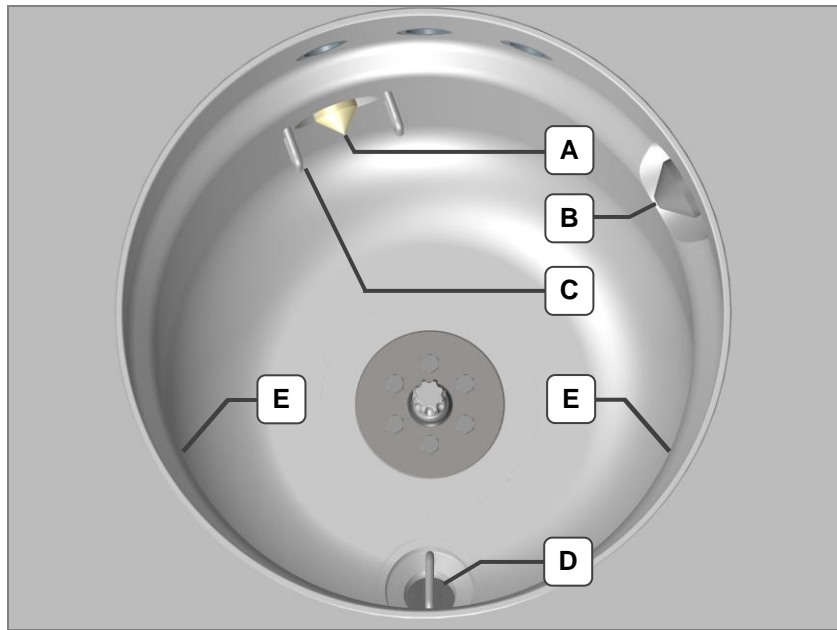

Fig.9.1.4.1 View of cleaning chamber

- A Filling level sensor** Work level
- B Filling level sensor** Overfilling level
- C Guard bar** (2 per sensor)
- D Sieve insert** for collecting lost precision parts and coarse particles when draining the cleaning / rinsing liquid from the cleaning chamber.
- E Heating areas** / radiating surfaces of the 2 heaters with radiant heat for the drying process.

## 9.1.5 Leak checks

<b>Recommended interval</b>	Daily
<b>Inspection criteria</b>	Leak tightness with respect to escaping media from the media-carrying tubes and couplings and the media tanks.
<b>Procedure</b>	Push up the protective grilles and perform a visual inspection (if visible) of the specified components. Pay attention to possible media residues on the base of the cleaning unit.

## 9.2 Continuous maintenance actions

### 9.2.1 Change of cleaning and rinsing media

<b>Recommended interval</b>	After view (visual inspection of the cleaning and rinsing media in the opened media tanks) and/or in the event of diminishing cleaning result.
<b>Inspection criteria</b>	There are several possibilities available for compliance with the intervals for the media change:
<b>Reminder on the display</b>	If a service life of the media has been saved using the display, an appropriate message is shown on the display.
<b>Manual monitoring</b>	If the media in the media tanks seem to be increasingly contaminated or the cleaning parts after cleaning no longer appear to be clean, the media must be changed.
<b>Only use permitted operating materials</b>	Only permitted media (cleaning / rinsing media) are permitted to be used for safety reasons and to prevent unit damage. Observe the instructions for recommended media and limitations for unsuitable / not permissible media ( <i>Chapter 8</i> ).



Fire and explosion hazard!

Observe the applicable safety regulations for handling solvents.

Keep all kinds of ignition sources away.

Prevent ignition sparks from electrostatic discharge. Discharge possible electrostatic charges (body charge) by touching any grounded equipment before handling flammable media: e.g. water tap, metal surface of the case of the cleaning unit or use ESD protective equipment (ESD arm band).

---

#### Procedure

Remove the relevant media tank from the cleaning unit.



The media tank must not be removed during running cleaning programs.

Drain the relevant media tank and clean if necessary.

Proceed as described in *Chapter 4.4* for refilling the media tanks.

Check the correct closing function of the quick couplings (*Chapter 4.4.1*) before reconnecting the media tanks.

#### Disposal of used media



Used media must be disposed of in accordance with the regulations. No disposal via the sewer system! Dispose of the used media in accordance with the national disposal regulations for the media (see safety data sheet).

## 9.2.2 Inspect media tanks, covers, suction filters

**Recommended interval** When changing the media

**Media tanks inspection criteria** Check the media tanks for leak tightness, e.g. damage such as cracks, and for not removable stubborn residues from soiling.

**Media tank cover inspection criteria** Check for damage, e.g. cracks, and the condition of the cover seal.

**Suction filter inspection criteria** Check for damage and residues from soiling.

**Media tanks, covers** Clean the components of the media tanks with a suitable cleaning agent, e.g. IPA.

**Suction filter** It is recommended to drain the media tank before removal / replacement of the suction filter.

1. Turn the quick coupling (*Fig. 9.2.2.1.C*) anticlockwise out of the media tank. The suction filter (*Fig. 9.2.2.1.G*) is now loose in the media tank.
2. Remove the suction filter, e.g. using suitable tweezers, from the media tank.

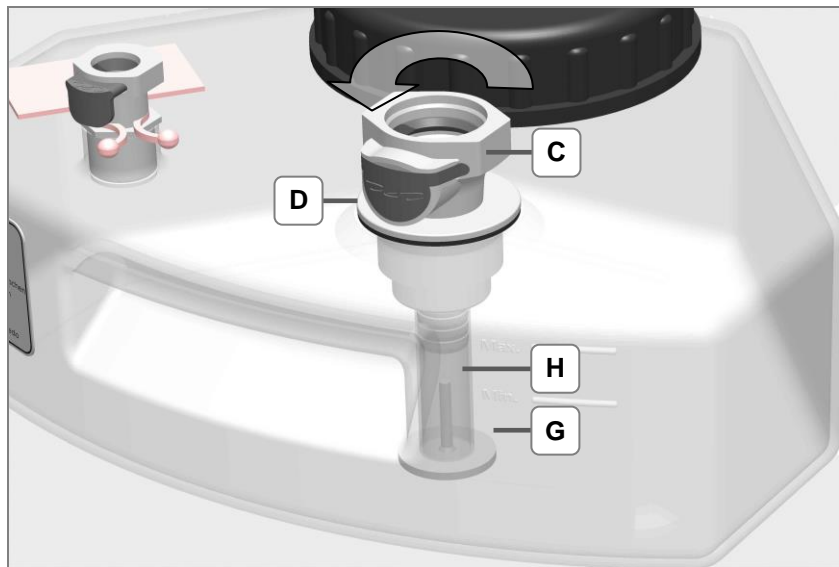



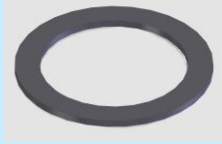

Fig. 9.2.2.1 Quick coupling and suction filter

3. Clean the filter fabric carefully using a suitable cleaning agent, e.g. IPA. Subsequent treatment with a brush or carefully with compressed air.
4. Replace the seal (D) if necessary.
5. Replace the filter on the floor of the media tank and screw in the quick coupling again. Ensure that the stem of the suction filter is located in the suction tube (*Fig. 9.2.2.1.C*) and can move freely.

Use the following article numbers for spare part orders:

Designation	Art. No.	Change interval	Illustration
Complete media tank	103 8653	Visual inspection	
Media tank	105 7126	Visual inspection	
Cover for media tank	104 4088	Visual inspection	
Coupling + tube	105 2475	Visual inspection	
Suction filter	105 2718	Visual inspection	
Coupling	105 2485	Visual inspection	
Seal	103 3131	Visual inspection	



## 9.2.3 Cleaning basket



Particularly when using third party baskets, there is an increased risk of wear of the bottom support surfaces.

### Recommended interval

When changing the media

### Basket holder inspection criteria

The support surfaces at the bottom of the basket holder must be flat (*Fig. 9.2.3.1.A*). In the case of wear (*Fig. 9.2.3.2.B*), the basket holder must be replaced.



### ATTENTION

If the specified surfaces are worn, there is the risk that the cleaning baskets are no longer correctly fixed in the basket holder. The consequence of this is that cleaning parts can be flung out of the cleaning baskets.

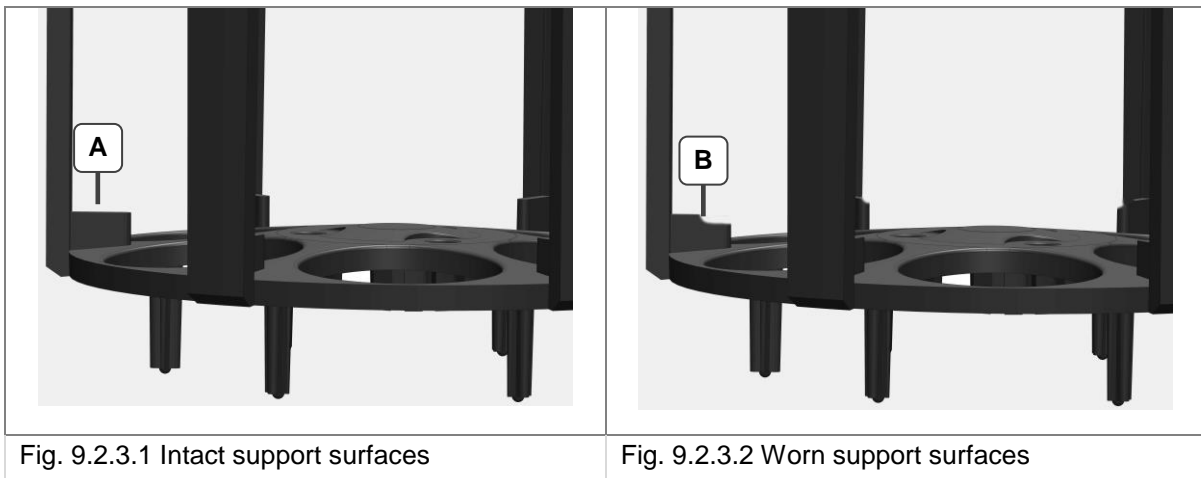

### Collar bushing inspection criteria

Check the tothing of the collar bushing (*Fig. 9.2.3.3.C*) for wear. The collar bushing must be replaced as soon as any wear on the tothing is recognisable (*Fig. 9.2.3.5.E*). Worn tothing of the collar bushing results in unbalance of the cleaning basket at higher speeds.

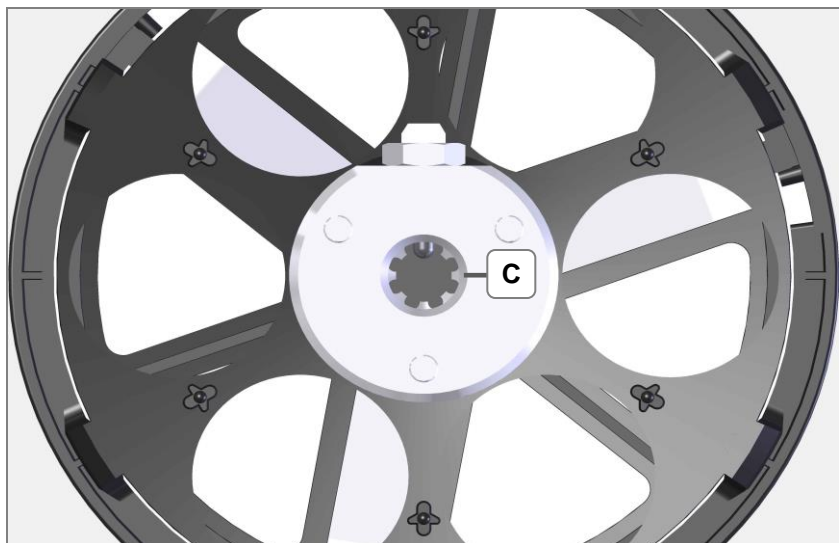

Fig. 9.2.3.3 Basket underside / position of the collar bushing

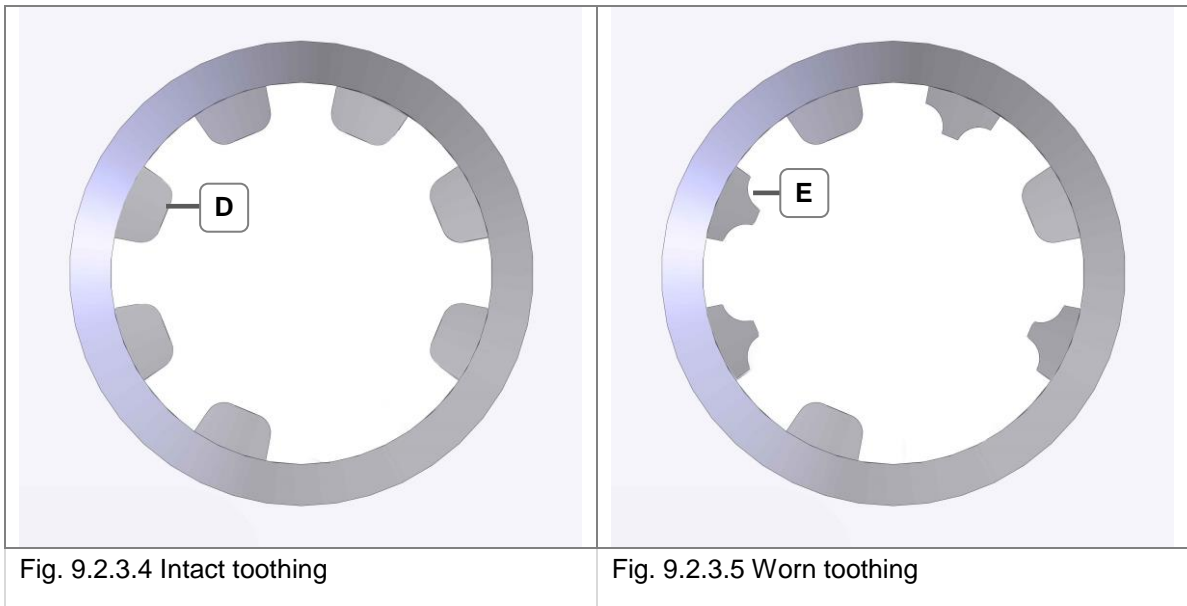



Fig. 9.2.3.4 Intact toothing

Fig. 9.2.3.5 Worn toothing

Use the following article numbers for spare part orders:

Designation	Art. No.	Change interval	Illustration
Basket holder, complete	105 3905	Visual inspection	
Basket locking	105 6436	Visual inspection	
Basket holder	104 5991	Visual inspection	
Basket mounting with collar bushing	104 6955	Visual inspection	

## 10

### Maintenance actions / service intervals

The service intervals concern all "dynamically" loaded sealing materials, the media tanks, the activated carbon unit and parts coming into contact with the media.



The warranty is void in the case of maintenance tasks not carried out or exceeding the intervals. The manufacturer shall not accept any liability for personal injuries and property damage resulting from maintenance not having been performed.

For safety reasons, strictly replace these components within the specified intervals.

#### Specified intervals

The components concerned are divided in various categories:

2-5 years service interval for components which can be replaced by the user. See *Chapter 10.1*.

5 years service interval for components which must be replaced by the Service Centre. See *Chapter 10.2*.

Service intervals according to the display which are performed by the Service Centre. See *Chapter 10.3*.

Automatic safety tests. These are performed automatically according to predefined requirements after confirming the cleaning cycle using the Start button.

- Simple safety test is performed after the cleaning unit has been disconnected from and reconnected to the mains power supply.
- Extended safety test is performed after 500 cleaning cycles, at the latest every 3 months. See *Chapter 10.4*.

### 10.1

#### 2-5 years service interval by user

The components listed below can easily be replaced by the user himself.

Order the required components using the details shown in good time from your dealer.

Instructions for replacement of the components can be found in *Chapter 10.1.1*.

Designation	Art. No.	Use	Illustration
Seal	105 0947	Cleaning chamber cover	

## 10.1.1 Replace seal for cleaning chamber cover

### Remove sealing ring

Remove the old sealing ring from the groove using a suitable tool (e.g. pliers).

Attention! The inside cover (*Fig. 10.1.1.1.A*) is only held in the cover by the sealing ring (*Fig. 10.1.1.1.B*). Hold the inside cover simultaneously.

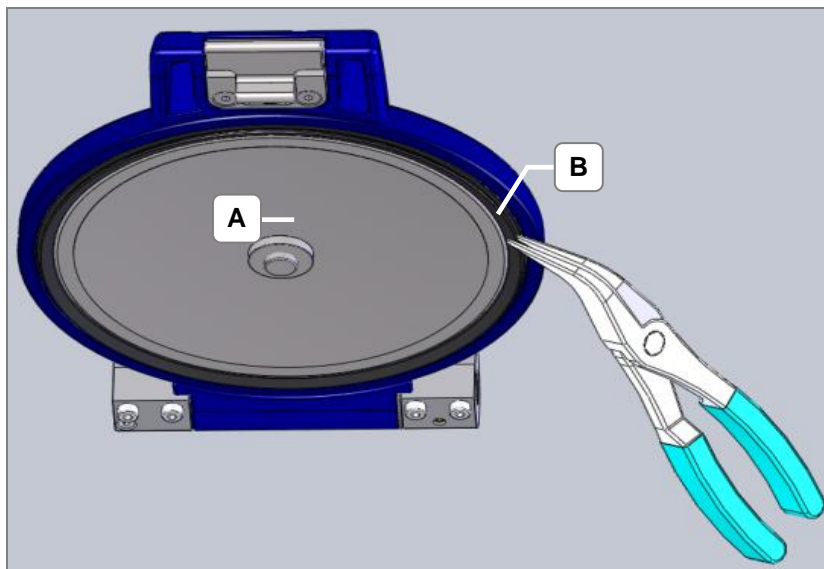

Fig. 10.1.1.1 Removing sealing ring

### Installing sealing ring

1. Place the new sealing ring around the removed inside cover.
2. Fit the inside cover with the sealing ring in the cover and press in the sealing ring evenly at 4 points (90° offset). Attention! The installation position of the sealing ring and the sealing lip (C) must first be aligned as shown in *Fig. 10.1.1.2*.
3. Turn the sealing ring as shown in *Fig. 10.1.1.3*. Arrow direction until the sealing lip is aligned as shown in *Fig. 10.1.1.3.C*.  
If the sealing lip is installed as shown in *Fig. 10.1.1.4*, turning to the installation position as shown in *Fig. 10.1.1.3* is no longer possible.

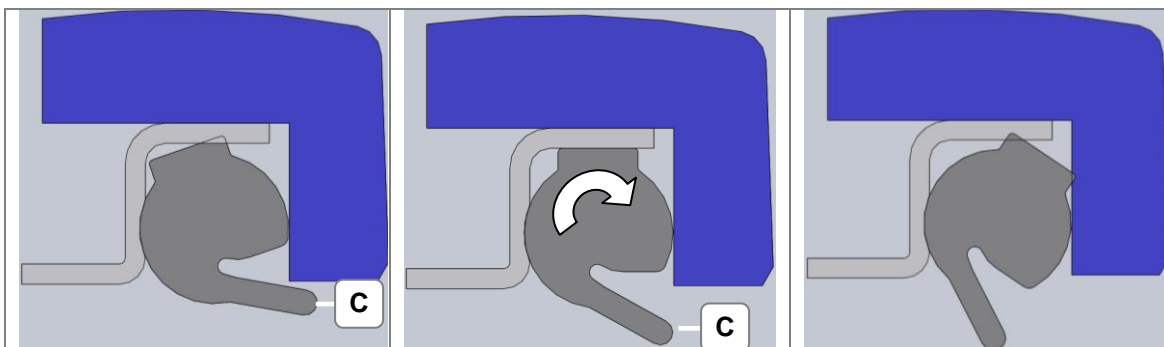

Fig. 10.1.1.2 – 1st step

Fig. 10.1.1.3 – 2nd step

Fig. 10.1.1.4 Attention!  
Incorrect!

## 10.2 5 years service interval by Service Centre

The components shown below must only be replaced by authorised Service Centres for safety reasons.

Contact your dealer or a Service Centre authorised by the manufacturer in good time to agree the further procedure.

### Exclusion of liability







Safe operation of the cleaning unit is no longer guaranteed. The required service must strictly be performed to continue operating the cleaning unit. The manufacturer shall not accept any liability for injuries to persons and property damage resulting from further operation.



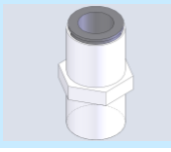

### 10.2.1 Prescribed parts to be replaced (mandatory)

Designation	Art. No.	Use	Illustration
Maintenance unit, complete set as shown below			105 2474
PTFE-sinter screw connection	104 5972	PTFE-sinter screw connection, cleaning chamber	
Basket rotation mounting	105 2496	Basket rotation unit	
Solenoid valve with connection	105 2499	Step motor	
Seal	105 0947	Cleaning chamber cover	
Sealing tape	101 6143		
Silencer	105 9991	Internal output, ventilation	

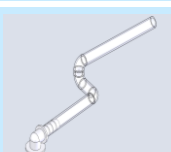
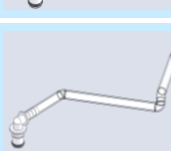
Other components such as solenoid valves, vacuum pump, electric actuators, elastomer seals and media tanks must be inspected in the course of the 5-years service and replaced as required (see *Chapter 10.2.2*).

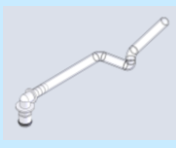
## 10.2.2 Recommended parts to be replaced

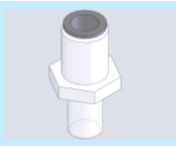
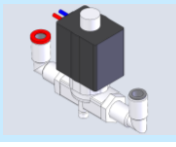
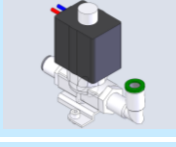
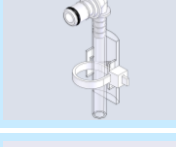
Designation	Quantity	Art. No.	Use	Illustration
Maintenance complete set as shown below	1	105 6674		
Coupling with tube	4	105 2475	quick coupling and suction filter	
Coupling with tube Pos 1	1	105 2490	Media tank - MWV (PTFE, PSU, FPM)	
Coupling with tube Pos 2	1	105 2489	Media tank - MWV (PTFE, PSU, FPM)	
Coupling with tube Pos 3+4	2	105 2488	Media tank - MWV (PTFE, PSU, FPM)	
Coupling	4	104 6196	Multi-way valve (POM, FPM)	
Coupling with PTFE sealing tape	4	105 2485	Media tank	
Coupling with tube Pos 1	1	105 2481	Media tank - MWV	
Coupling with tube Pos 2	1	105 2482	Media tank - MWV	

Coupling with tube Pos 3+4	2	105 2483	Media tank - MWV	
Coupling	2	103 4060	Outlet	
Coupling	4	103 8468	Multi-way valve	
Solenoid valve with fitting	1	105 2497	Step motor	
Solenoid valve with fitting	1	105 2498	Step motor	
Connection set	2	104 8988	Case outlet (POM, FPM, PTFE)	
Connection set	1	104 6955	Basket mounting with collar bushing	
Sealing tape PTFE	1	101 6143		

## 10.3 Service intervals according to display message

The components shown below are indicated by a corresponding notification on the display when a predefined degree of wear is reached.

### 10.3.1 Replace seal of the basket rotation unit



The seal of the basket rotation unit must be replaced after approx. 550 operating hours with speed  $n \geq 300$  rpm; however after 5 years at the latest.

This maintenance task must only be performed by an authorised Service Centre. Contact a Service Centre authorised by the manufacturer to arrange carrying out the necessary maintenance.

#### Display

As soon as remaining running time of 4,000 operating minutes is reached (corresponds to approx. 1,000 standard cleaning cycles), the following is first shown on the display: *Attention A change of the rotation seal becomes due Estimated number of standard programs remaining 1000 (Fig. 10.3.1.1).*

A new and in each case one-time notification is shown when reaching remaining running time of 900, 800, 700, ...100 standard cleaning cycles.

A continuous notification is shown when reaching remaining running time of 100, 99, 98, ...1 standard cleaning cycles.

The display notification is shown after every program run as soon as the operating hours are reached / exceeded: *Warning! Contact the service. Change of the rotation seal is necessary! See operating instructions. (Fig. 10.3.1.2).* The cleaning unit must no longer be operated! The manufacturer shall not be liable!

#### Exclusion of liability



Safe operation of the cleaning unit is no longer guaranteed. The required service must strictly be performed to continue operating the cleaning unit. The manufacturer shall not accept any liability for injuries to persons and property damage resulting from further operation.

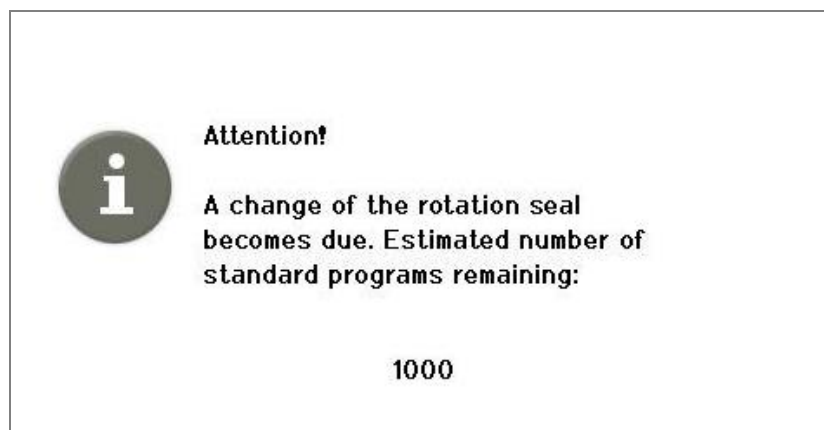

Fig. 10.3.1.1 Display *Change rotation seal*



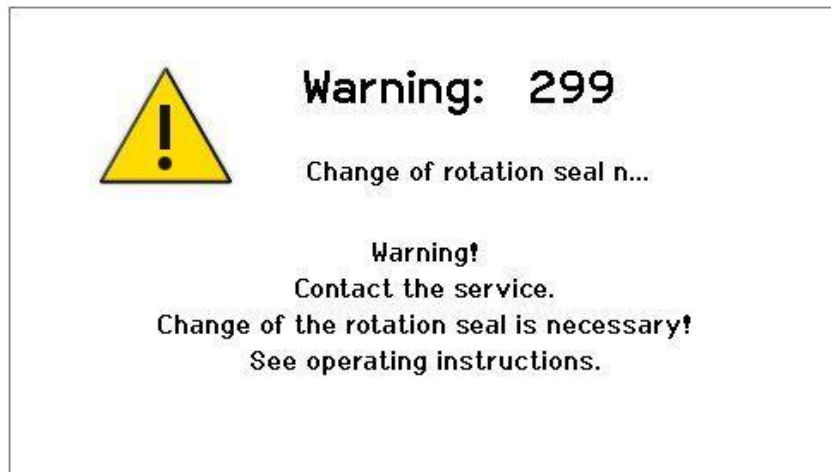

Fig. 10.3.1.2 Display *Warning: Change of rotation seal...*

## 10.4 Extended safety test

An extended safety test is automatically performed by the cleaning unit after every 500 cleaning cycles or at the latest quarterly. A corresponding message is shown on the display. This must be confirmed with **OK** to start the safety test.

**i** In each case the execution of the safety test can be postponed three times with **ESC**; then the safety test must be started (*Fig. 10.4.1*). Another start of the cleaning unit is not possible again until after the extended safety test has been performed.



Fig. 10.4.1 Display *Start safety test*

For this extended safety test, the function of the *overflowing level* filling level sensor is tested by suctioning medium.

In the case of possible malfunction of the overflowing level sensor, medium can escape. This should be collected by the collecting container.

It is required here that the exhaust air tube included in the scope of delivery is connected to the ventilation connection of the cleaning chamber (*Fig. 4.3.1.A*). The end of the exhaust air tube must be immersed in a collecting container ( $\geq 1.5$  litres) during this test.

Before performing the safety test, ensure that media tank #4 is filled between the Min and Max markings.

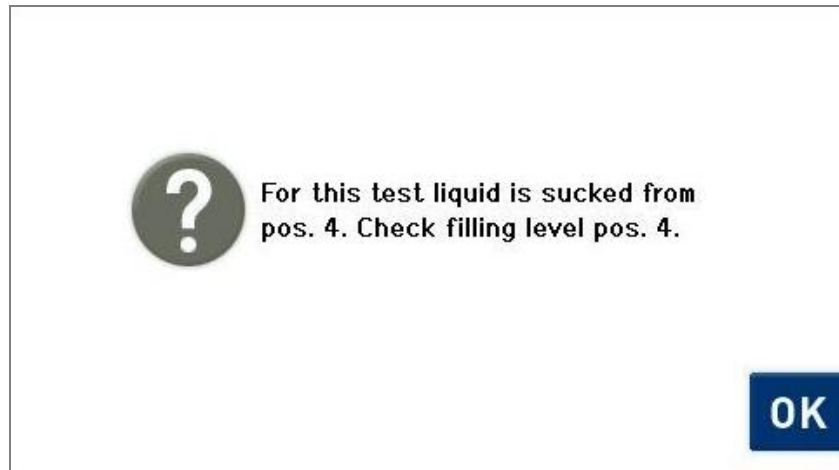

Fig. 10.4.2 Display *Check filling level pos. 4*

Confirm the correct filling level with **OK** (Fig. 10.4.2).

The safety test is now started automatically and ends after approx. 5 minutes. The progress is shown on the display (Fig. 10.4.3).



Fig. 10.4.3 Display *Safety Test* progress

## 11 Operating faults

Operating faults of the cleaning unit are mainly shown as error messages on the display.

A list of the possible error messages and the relevant procedures for fault clearance can be found in *Chapter 11.1*.

Further possible faults can be found listed in *Chapter 11.2*.

Individual actions for fault clearance which can be performed by the user can be found in *Chapter 11.3*.

If any fault cannot be rectified using the measures specified in the troubleshooting, contact the dealer or manufacturer immediately.



**DANGER**

For safety reasons, repairs must only be performed by service centres which have been authorised by the manufacturer.

The manufacturer shall accept no liability for damage caused by unauthorised and incorrect interventions on the cleaning unit.

### 11.1

#### Fault messages on the display

Possible malfunctions of the cleaning unit are shown on the display as fault messages.

In the case of operating faults where the program still runs to the end, a warning is shown on the display during the cleaning process (see *Fig. 11.1.1.A*). Pressing the operating button (see *Fig. 11.1.1.B*) displays fault information.



Fig. 11.1.1 Display *Fault message* (example)

Fault message	Fault description	Fault clearance
<p><b>Error No. 51 - 82</b>            Abortion            Critical fault!            Explosion safety not guaranteed.            Program has not been ended.</p>	<p>Medium possibly drains too slowly.            This trips the vacuum safety switch.            Outlet or inlet path of the medium clogged and/or ventilation openings on the cleaning unit blocked.</p>	<p>Check whether the following places are blocked / clogged / soiled:</p> <ul style="list-style-type: none"> <li>• Ventilation openings (2) and filter in the interior of the machine.</li> <li>• Condensate separator, activated carbon filter or exhaust air tube.</li> <li>• Sieve insert</li> <li>• Suction filters in the media tanks</li> <li>• Work level filling level sensor (clean with suitable cloth if necessary)</li> <li>• Check work level filling level sensor for damage (scratches, cracks)</li> </ul> <p>Mechanical tests:</p> <ul style="list-style-type: none"> <li>• Can the valve of the quick coupling on the tube be pressed in?</li> <li>• Can the valve of the quick coupling on the media tank be pressed in?</li> <li>• Switch off cleaning unit and restart:            Contact Service if the fault persists.</li> </ul>
<p><b>Error No. 83-114</b>            Abortion            Critical fault!            Cleaning chamber overfilled            Program has not been ended.</p>	<p>Tripping of the overfilling level filling level sensor or            Filling level sensor for overfilling level tripped more than three times, however only for a short time, (multiple splashes) during any process step</p>	<p>Check the following possibilities:</p> <ul style="list-style-type: none"> <li>• Whether cleaning basket is installed</li> <li>• Whether sieve insert basket is installed</li> <li>• Whether filling level in the media tank is too low and air is drawn into the working chamber as a result</li> <li>• Whether filling level in the media tank is too low</li> <li>• Whether work level and overfilling level filling level sensors are soiled (clean with suitable cloth if necessary)</li> <li>• Whether work level and overfilling level filling level sensors are damaged (scratches, cracks)</li> <li>• Whether temperature of the medium in the media tank, which the indicated partial step in the error refers to, is already too high (see temperature table for Warning 211)</li> <li>• Boiling retardations in the working chamber cause frequent splashes above the media surface and tripping of the sensor</li> <li>• Remedy: use cooled medium for the indicated process step (see also procedural recommendation in <i>Chapter 16</i>).</li> </ul>

		<ul style="list-style-type: none"> <li>• Whether gas content in the cleaning medium is too high: Switch off the ultrasound and basket oscillation temporarily to degas the cleaning medium slower.</li> <li>• Check deflection and frequency rate oscillation parameters.</li> <li>• Switch off cleaning unit and restart: Contact Service if the fault persists.</li> </ul>
<p>115-146 Warning A fan is not functioning correctly. Program is not ended properly. The cleaning unit cannot be restarted while the fault is present.</p>	A fan is blocked or defective.	<p>Check the following possibilities:</p> <ul style="list-style-type: none"> <li>• Check fans for foreign bodies and remove if necessary.</li> <li>• Switch off cleaning unit and restart: Contact Service if the fault persists.</li> </ul>
<p>147-178 Warning Working level filling level not correct.</p>	Filling level in cleaning chamber not optimal (or fluctuates from time to time).	<p>Check the following possibilities:</p> <ul style="list-style-type: none"> <li>• Whether cleaning basket is installed</li> <li>• Whether sieve insert basket is installed</li> <li>• Whether filling level in the media tank is too low</li> <li>• Whether work level and overfilling level filling level sensors are soiled (clean with suitable cloth if necessary)</li> <li>• Whether work level and overfilling level filling level sensors are damaged (scratches, cracks)</li> <li>• Whether gas content in the cleaning medium is too high: Switch off the ultrasound and basket oscillation temporarily to degas the cleaning medium</li> <li>• Switch off cleaning unit and restart: Contact Service if the fault persists</li> </ul>
<p>179 The temperature in the chamber is too high! The cleaning is aborted when 45 °C is reached.</p>	Media temperature in the cleaning chamber in the indicated step of the cleaning process too high ( $\geq 40\text{ °C} < 45\text{ °C}$ ).	<p>Check the following possibilities:</p> <ul style="list-style-type: none"> <li>• Ambient temperature must be <math>&lt; 30\text{ °C}</math></li> <li>• Measure temperature of the medium in the media tank referred to in the partial step indicated in Warning 211 Boiling range lower   Permitted limit of the medium<sup>*)</sup>   media temp  <math>T_s &gt; 100\text{ °C}</math>   <math>T &lt; 45\text{ °C}</math>                      *) according to safety data sheet</li> <li>• Cleaning cycles are started at too short intervals</li> <li>• Media heating due to too long-lasting ultrasound impact. Remedy: See procedural recommendations in <i>Chapter 16</i></li> </ul>

		<ul style="list-style-type: none"> <li>Let cleaning unit cool down and restart: Contact Service if the fault persists</li> </ul>
<p>180 Program is aborted due to overtemperature (&gt; 45 °C)! Wait until the process is ended.</p>	<p>Media temperature in the cleaning chamber too high (&gt; 45 °C).</p>	<p>Check the following possibilities:</p> <ul style="list-style-type: none"> <li>Ventilation slots blocked</li> <li>Ambient temperature must be &lt; 30 °C</li> <li>Media temperature and media heating – see <i>Warnings 179 and 211</i></li> <li>Cleaning cycles are started at too short intervals</li> <li>Let cleaning unit cool down and restart: Contact Service if the fault persists</li> </ul>
<p>181 Warning! Small temperature change during the heating process</p>	<p>Temperature measurement defective, the measured temperature does not change as intended during the heating up (e.g. temperature sensor has detached itself from the cleaning chamber, heaters are defective).</p>	<p>Check the following possibilities:</p> <ul style="list-style-type: none"> <li>Switch off cleaning unit and restart: Contact Service if the fault persists.</li> </ul>
<p>201 Abortion Critical fault! MWV drive defective. Program has not been ended.</p>	<p>Multi-way valve does not reach position / overshoots position / may be stiff.</p>	<p>Check the following possibilities: First, place collecting container (&gt;= 1.5 litres) at the bottom case outlet (<i>Fig.4.3.1.B</i>)</p> <ul style="list-style-type: none"> <li>Disconnect cleaning unit from mains power supply and restart</li> <li>In the event of liquid discharge from the bottom case outlet: For further procedure, see point <i>Liquid discharge from bottom case opening (Chapter 11.2)</i></li> <li>Disconnect cleaning unit from the mains power supply</li> <li>Correct media tanks filling levels</li> <li>Switch off cleaning unit and restart: Contact Service if the fault persists</li> </ul>
<p>202 Abortion Critical fault! Pressure measurement defective. Program has not been ended.</p>	<p>Pressure measurement failure: Sensor or electronics fault.</p>	<p>Check the following possibilities:</p> <ul style="list-style-type: none"> <li>Switch off cleaning unit and restart: Contact Service if the fault persists</li> </ul>
<p>203 Abortion Critical fault! Temperature measurement defective.</p>	<p>Temperature measurement failure.</p>	<p>Check the following possibilities:</p> <ul style="list-style-type: none"> <li>Switch off cleaning unit and restart: Contact Service if the fault persists</li> </ul>

## Operating faults

Program has not been ended.		
204 Abortion Critical fault! Overfilling level filling level sensor defective. Program has not been ended.	Plausibility error (working level filling level sensor, overfilling level filling level sensor).	Check the following possibilities: <ul style="list-style-type: none"> <li>• Switch off cleaning unit and restart: Contact Service if the fault persists</li> </ul>
205 Abortion Both fans are defective or blocked! Program has not been ended.	Failure of both fans.	Check the following possibilities: <ul style="list-style-type: none"> <li>• Check fans for foreign bodies and remove if necessary</li> <li>• Switch off cleaning unit and restart: Contact Service if the fault persists</li> </ul>
211 Warning Evacuation gradient too low.	Vacuum in the working chamber is reached too slowly in the indicated step of the cleaning process. Possible cause is too high media temperature in the tank.	Check the following possibilities: <ul style="list-style-type: none"> <li>• Media tank cover: closed correctly, seal OK?</li> <li>• Measure temperature of the medium in the media tank referred to in the partial step indicated in Warning 211. Boiling range lower   Permitted limit of the medium<sup>*)</sup>   media temp  <math>T_s &gt; 100 \text{ °C} \mid T &lt; 45 \text{ °C}</math>  <math>80 &lt; T_s &lt; 100 \text{ °C} \mid T &lt; 30 \text{ °C}</math>  <math>70 &lt; T_s &lt; 80 \text{ °C} \mid T &lt; 25 \text{ °C}</math>  <sup>*)</sup> according to safety data sheet Remedy: <ul style="list-style-type: none"> <li>• Condensate separator, activated carbon filter or exhaust air tube clogged?</li> <li>• Check quick coupling on the tube (can the valve be pressed in?)</li> <li>• Check quick coupling on the media tank (can the valve be pressed in?)</li> <li>• Is quick coupling securely engaged? (see page 25 – point 7)</li> <li>• Switch off cleaning unit and restart: Contact Service if the fault persists</li> </ul> </li> </ul>
212 Abortion Evacuation gradient too low. Explosion safety not guaranteed. Program has not been ended.	Timeout, vacuum is not achieved. Possible cause: Scooping parts with larger quantity of last rinsing medium not draining (see cause for 211).	Check the following possibilities: <ul style="list-style-type: none"> <li>• Media tank cover: closed correctly, seal OK?</li> <li>• Avoid scooping arrangement of parts – position parts in the basket favourably for draining</li> <li>• Condensate separator, activated carbon filter or exhaust air tube clogged?</li> </ul>



		<ul style="list-style-type: none"> <li>• Check quick coupling on the tube (can the valve be pressed in?)</li> <li>• Check quick coupling on the media tank (can the valve be pressed in?)</li> <li>• Is quick coupling securely engaged? (see page 25 – point 7)</li> <li>• Switch off cleaning unit and restart: Contact Service if the fault persists</li> </ul>
<p>213 Abortion Error! No filling from position 3 (example).</p>	<p>Cleaning chamber cannot be filled.</p>	<p>Check the following possibilities:</p> <ul style="list-style-type: none"> <li>• Check cover (seal)</li> <li>• Condensate separator, activated carbon filter or exhaust air tube clogged?</li> <li>• Sieve inserts soiled?</li> <li>• Filling level in the media tank is too low</li> <li>• Check quick coupling on the tube (can the valve be pressed in?)</li> <li>• Is quick coupling securely engaged? (see page 25 – point 7)</li> <li>• Check suction filter in the media tank</li> <li>• Check working level <i>filling level sensor</i> and <i>overflowing level</i> filling level sensor for soiling; clean with suitable cloth if necessary</li> <li>• Check sensor for damage (scratches, cracks)</li> <li>• Switch off cleaning unit and restart: Contact Service if the fault persists</li> </ul>
<p>214 Abortion Error! Cleaning chamber is not filled Check media tank filling level, tubes etc. Program has not been ended.</p>	<p>Timeout during filling of the cleaning chamber: Timeout of the working level filling level sensor.</p>	<p>Check the following possibilities:</p> <ul style="list-style-type: none"> <li>• Check cover (seal)</li> <li>• Condensate separator, activated carbon filter or exhaust air tube clogged?</li> <li>• Sieve inserts soiled?</li> <li>• Filling level in the media tank is too low</li> <li>• Check quick coupling on the tube (can the valve be pressed in?)</li> <li>• Is quick coupling securely engaged? (see page 25 – point 7)</li> <li>• Check suction filter in the media tank</li> <li>• Check working level <i>filling level sensor</i> and <i>overflowing level</i> filling level sensor for soiling, clean with suitable cloth if necessary</li> <li>• Check sensor for damage (scratches,</li> </ul>

		<p>cracks)</p> <ul style="list-style-type: none"> <li>• Switch off cleaning unit and restart: Contact Service if the fault persists</li> </ul>
<p>215 Abortion Critical fault! Venting not possible. Program has not been ended.</p>	<p>Vacuum in the cleaning chamber is not released.</p>	<p>Check the following possibilities:</p> <ul style="list-style-type: none"> <li>• Check ventilation openings (2) and filter in the interior of the machine opening for free accessibility</li> <li>• Condensate separator, activated carbon filter or exhaust air tube clogged?</li> <li>• Switch off cleaning unit and restart: Contact Service if the fault persists</li> </ul>
<p>216 Cleaning chamber drains slowly.</p>	<p>Timeout 1 of the <i>level empty</i> filling level sensor during draining of the cleaning chamber.</p>	<p>Check the following possibilities:</p> <ul style="list-style-type: none"> <li>• Condensate separator, activated carbon filter or exhaust air tube clogged?</li> <li>• Sieve inserts soiled?</li> <li>• Filling level in the media tank is too high</li> <li>• Check quick coupling on the tube (can the valve be pressed in?)</li> <li>• Is quick coupling securely engaged? (see page 25 – point 7)</li> <li>• Check suction filter in the media tank</li> <li>• Check working level <i>filling level sensor</i> and <i>overflowing level</i> filling level sensor for soiling; clean with suitable cloth if necessary</li> <li>• Switch off cleaning unit and restart: Contact Service if the fault persists</li> </ul>
<p>217 Abortion Error! Cleaning chamber drains too slowly. Wait, then remove and clean sieve insert.</p>	<p>Timeout 2 of the level empty filling level sensor during draining.</p>	<p>Check the following possibilities:</p> <ul style="list-style-type: none"> <li>• Condensate separator, activated carbon filter or exhaust air tube clogged?</li> <li>• Sieve inserts soiled?</li> <li>• Filling level in the media tank too high?</li> <li>• Check quick coupling on the tube (can the valve be pressed in?)</li> <li>• Is quick coupling securely engaged? (see page 25 – point 7)</li> <li>• Check suction filter in the media tank</li> <li>• Switch off cleaning unit and restart: Contact Service if the fault persists</li> </ul>
<p>218 Abortion Error! Cleaning chamber does not drain.</p>	<p>Timeout of the working level filling level sensor during draining of the cleaning chamber.</p>	<p>Check the following possibilities:</p> <ul style="list-style-type: none"> <li>• Condensate separator, activated carbon filter or exhaust air tube clogged?</li> <li>• Sieve inserts soiled?</li> </ul>

		<ul style="list-style-type: none"> <li>• Check whether filling level in the media tank is overfilled</li> <li>• Check quick coupling on the tube (can the valve be pressed in?)</li> <li>• Is quick coupling securely engaged? (see page 25 – point 7)</li> <li>• Check suction filter in the media tank</li> <li>• Switch off cleaning unit and restart: Contact Service if the fault persists</li> </ul>
220 – 234 Abortion Critical fault! MWV drive defective.	Failure of multi-way valve rotary encoder.	<p>Check the following possibilities: First, place collecting container (&gt;= 1.5 litres) at the bottom case outlet</p> <ul style="list-style-type: none"> <li>• Disconnect cleaning unit from mains power supply and restart</li> <li>• In the event of liquid discharge from the bottom case outlet: See <i>Chapter 11.2</i> for the further procedure. Liquid discharge from the bottom case opening</li> <li>• Disconnect cleaning unit from the mains power supply</li> <li>• Correct media tanks filling levels</li> <li>• Switch off cleaning unit and restart: Contact Service if the fault persists</li> </ul>
251-255, 262, 263, 264 Abortion Critical fault!	Malfunction of various components (during the automatic safety test).	<p>Check the following possibilities:</p> <ul style="list-style-type: none"> <li>• Media tank cover: closed correctly, seal OK?</li> <li>• Condensate separator, activated carbon filter or exhaust air tube clogged?</li> <li>• Check ventilation openings (2) and filter in the interior of the machine opening for free accessibility</li> <li>• Switch off cleaning unit and restart: Contact Service if the fault persists</li> </ul>
265 Abortion Critical fault! Overfilling level filling level sensor defective.	Malfunction of the overfilling level filling level sensor (during the extended automatic safety test).	<p>Check the following possibilities:</p> <ul style="list-style-type: none"> <li>• Check working level <i>filling level sensor</i> and <i>overfilling level filling level sensor</i> for soiling; clean with suitable cloth if necessary</li> <li>• Check sensor for damage (scratches, cracks)</li> <li>• Switch off cleaning unit and restart: Contact Service if the fault persists</li> </ul>
266 Abortion Critical fault! Level empty filling level sensor defective.	Malfunction of the <i>level empty</i> filling level sensor (during the automatic safety test).	<p>Check the following possibilities:</p> <ul style="list-style-type: none"> <li>• Whether cleaning chamber is empty</li> <li>• Switch off cleaning unit and restart: Contact Service if the fault persists</li> </ul>
267	Malfunction of the working	Check the following possibilities:

## Operating faults

<p>Abortion Critical fault! Working level filling level sensor defective.</p>	<p>level filling level sensor (during the automatic safety test).</p>	<ul style="list-style-type: none"> <li>• Whether cleaning chamber is empty</li> <li>• Check sensor for damage (scratches, cracks)</li> <li>• Switch off cleaning unit and restart: Contact Service if the fault persists</li> </ul>
<p>268 Abortion Critical fault! Vacuum is not achieved.</p>	<p>Vacuum cannot be achieved (during the automatic safety test).</p>	<p>Check the following possibilities:</p> <ul style="list-style-type: none"> <li>• Check cover (seal)</li> <li>• Condensate separator, activated carbon filter or exhaust air tube clogged?</li> <li>• Check quick coupling on the tube (can the valve be pressed in?)</li> <li>• Is quick coupling securely engaged? (see <i>page 25 – point 7</i>)</li> <li>• Switch off cleaning unit and restart: Contact Service if the fault persists</li> </ul>
<p>269 Abortion Critical fault! Slow venting not possible.</p>	<p>Vacuum in the cleaning chamber is not released (during the automatic safety test).</p>	<p>Check the following possibilities:</p> <ul style="list-style-type: none"> <li>• Check ventilation openings (2) and filter in the interior of the machine opening for free accessibility</li> <li>• Switch off cleaning unit and restart: Contact Service if the fault persists</li> </ul>
<p>270 Abortion Critical fault! Fast venting not possible.</p>	<p>Vacuum in the cleaning chamber is not released (during the automatic safety test).</p>	<p>Check the following possibilities:</p> <ul style="list-style-type: none"> <li>• Check ventilation openings (2) and filter in the interior of the machine opening for free accessibility</li> <li>• Switch off cleaning unit and restart: Contact Service if the fault persists</li> </ul>
<p>271 Abortion Critical fault! Basket rotation drive defective.</p>	<p>Basket rotation drive communication error and speed fault (during the automatic safety test).</p>	<p>Check the following possibilities:</p> <ul style="list-style-type: none"> <li>• Check correct seating of the cleaning basket</li> <li>• Switch off cleaning unit and restart: Contact Service if the fault persists</li> </ul>
<p>272 Abortion Critical fault! Ultrasound generator defective.</p>	<p>Ultrasound generator communication error (during the automatic safety test).</p>	<p>Check the following possibilities:</p> <ul style="list-style-type: none"> <li>• Switch off cleaning unit and restart: Contact Service if the fault persists</li> </ul>
<p>273 Abortion Critical fault! Fan defective.</p>	<p>A fan is blocked or defective (during the automatic safety test).</p>	<p>Check the following possibilities:</p> <ul style="list-style-type: none"> <li>• Check fans for foreign bodies and remove if necessary</li> <li>• Switch off cleaning unit and restart: Contact Service if the fault persists</li> </ul>
<p>274 Abortion Critical fault! Both fans defective.</p>	<p>Both fans are blocked or defective (during the automatic safety test).</p>	<p>Check the following possibilities:</p> <ul style="list-style-type: none"> <li>• Check fans for foreign bodies and remove if necessary</li> <li>• Switch off cleaning unit and restart: Contact Service if the fault persists</li> </ul>

<p>276, 277 Abortion Critical fault! Software / electronics error.</p>	<p>Software / electronics error.</p>	<p>Check the following possibilities:</p> <ul style="list-style-type: none"> <li>• Switch off cleaning unit and restart: Contact Service if the fault persists</li> </ul>
<p>278 Abortion Critical fault! Memory chip defective.</p>	<p>Software / electronics error.</p>	<p>Check the following possibilities:</p> <ul style="list-style-type: none"> <li>• Switch off cleaning unit and restart: Contact Service if the fault persists</li> </ul>
<p>291 Abortion Critical fault! Basket drive defective or blocked.</p>	<p>Basket rotation drive defective or blocked.</p>	<p>Check the following possibilities:</p> <ul style="list-style-type: none"> <li>• Check motor shaft of the basket rotation drive for ease of movement.</li> <li>• Switch off cleaning unit and restart: Contact Service if the fault persists</li> </ul>
<p>292 Warning Critical fault! Ultrasound generator defective.</p>	<p>No communication with ultrasound generator.</p>	<p>Check the following possibilities:</p> <ul style="list-style-type: none"> <li>• Switch off cleaning unit and restart: Contact Service if the fault persists</li> </ul>
<p>297 Warning! After pressing the button with the warning symbol: heater was switched off during the drying as liquid was detected.</p>	<p>If liquid is detected at the lower filling level sensor (or this sensor is defective) during the drying, the heater is switched off and the warning message is displayed.</p>	<p>Check the following possibilities:</p> <ul style="list-style-type: none"> <li>• Switch off cleaning unit and restart: Contact Service if the fault persists</li> </ul>

**Fault information:** This screen (*Fig. 11.1.2*) is always displayed if the cleaning program has not been ended properly: e.g. after any fault in the cleaning unit or a power failure during cleaning.

**Checking**

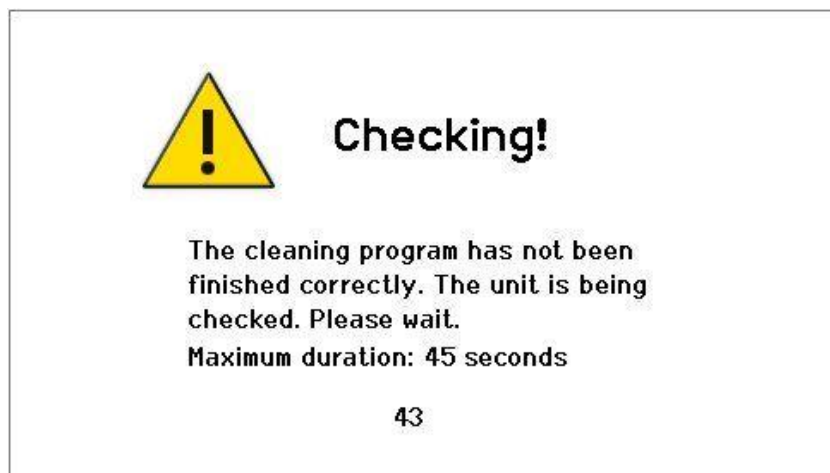

Fig. 11.1.2 Fault information for unit checking

## 11.2 Unit faults without indication on the display

Fault	Fault clearance
Cleaning unit cannot be started or stops.	Check the following possibilities: <ul style="list-style-type: none"> <li>• Disconnect cleaning unit from the mains power supply. Then check fuse(s) for mains cable; replace if necessary</li> <li>• Switch off cleaning unit and restart: Contact Service if the fault persists</li> </ul>
Liquid discharge from bottom case opening.	Check the following possibilities: <ul style="list-style-type: none"> <li>• Check media tank filling level</li> <li>• Cleaning deflagration protection (see <i>Chapter 11.3.1</i>)</li> <li>• Contact Service if the fault persists</li> </ul>

## 11.3 Fault clearance by user



**DANGER**

Risk of electric shock from live parts in the interior of the cleaning unit!

Always unplug the mains plug before opening the cleaning unit.  
The manufacturer shall accept no liability for damage caused by unauthorised interventions on the cleaning unit.



**CAUTION**

Risk of injury from sharp edges in the cleaning unit and from moving / rotating components (e.g. toothed belts).



**CAUTION**

Risk of injury from hot surfaces!

The vacuum pump, solenoid valves, drives and heater can still be hot immediately after operation of the cleaning units.

## 11.3.1

**Cleaning deflagration protection**

If liquid discharges at the bottom connection for venting the media tanks (*Fig. 11.3.1.1.G*), the deflagration protection should be cleaned afterwards.

**Procedure**

1. Remove the two 3 mm Allen screws (*Fig. 11.3.1.1.A*) on the bottom of the unit.
2. Remove the four 3 mm Allen screws (*Fig. 11.3.1.2.B*) on the rear side of the unit and remove the cover (*Fig. 11.3.1.2.C*) of the service opening.
3. Detach the two tube connections (*Fig. 11.3.1.2.E*) by pulling on the respective tube and simultaneously pressing on the grey ring (*Fig. 11.3.1.3.F*).
4. Remove the deflagration protection (*Fig. 11.3.1.3.D*) and drain the residual liquid present.
5. Let the deflagration protection dry (leave for approx. 30 minutes in the removed condition or blow out with compressed air).
6. Reinstall the deflagration protection in the unit in reverse order.

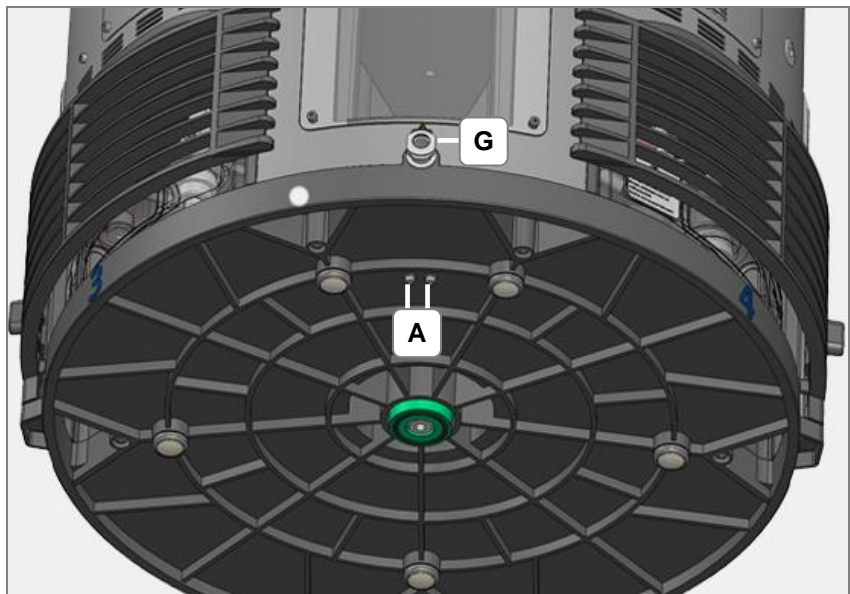

Fig. 11.3.1.1 Bottom view of unit with screw connection

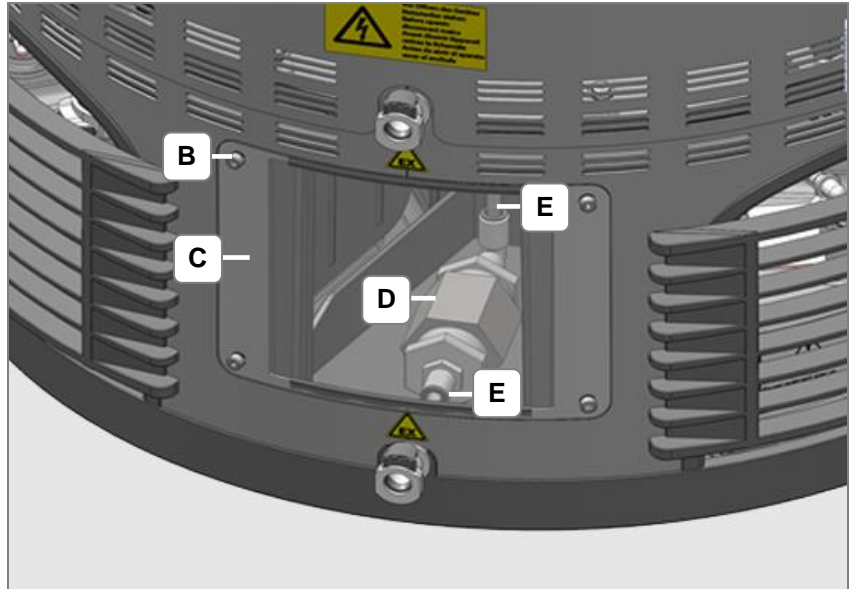

Fig. 11.3.1.2 Service opening with deflagration protection

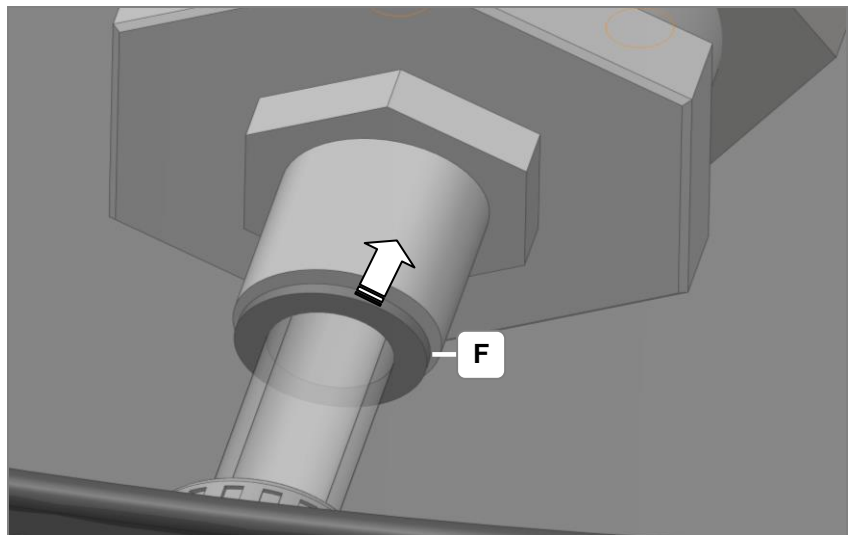

Fig. 11.3.1.3 Tube connection with locking ring

  
**ATTENTION**

In the event of further discharge of liquid (> droplets), the cleaning units must not be further operated. Contact your dealer or the manufacturer.



### 11.3.2

## Manual venting of the cleaning chamber



If the medium is not conducted from the cleaning chamber back into the media tank, there can be a fault for the automatic venting.

The following error message is shown on the display: *Cleaning chamber does not drain.*

The cleaning chamber can be vented manually using the bleed screw in the cover of the cleaning chamber.

#### Procedure

Open the bleed screw using a 5 mm Allen key. There is a feedthrough for the Allen key in the handle of the cover of the cleaning chamber.

By removal of the vacuum in the cleaning chamber, the medium should flow back into the relevant media tank.

If this is not the case, contact the Service Centre.

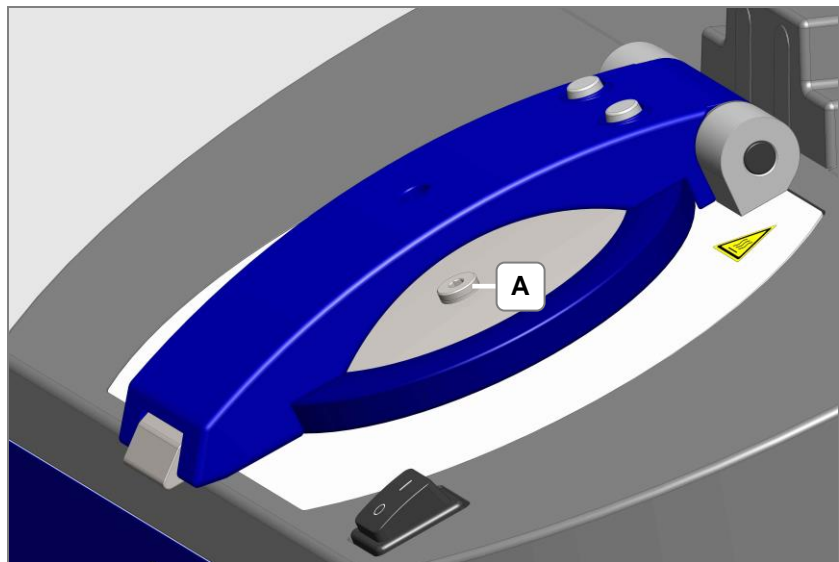

Fig. 11.3.2.1 Position of the bleed screw

## 11.4

### Repairs

---



**DANGER**

For safety reasons, repairs must only be performed by service centres which have been authorised by the manufacturer.

The manufacturer shall accept no liability for damage caused by unauthorised and incorrect interventions on the cleaning unit.

---

**Opening must only be performed by authorised qualified electricians**

Risk of electric shock from live parts in the interior of the cleaning unit!

Always unplug the mains plug before opening the cleaning unit.



The manufacturer shall accept no liability for damage caused by unauthorised interventions on the cleaning unit.

---



**CAUTION**

Risk of injury from sharp edges in the cleaning unit and from moving / rotating components (e.g. toothed belts).

---



**CAUTION**

Risk of injury from hot surfaces!

The vacuum pump, solenoid valves, drives and heater can still be very hot immediately after operation of the cleaning units.

---

Contact the supplier or manufacturer in the case of cleaning unit faults which cannot be rectified using the instructions for fault clearance in this operating manual.

If any return to a service centre is required:

- use the original packaging to prevent transport damage.
- enclose as specific as possible description of the fault.

12

## Decommissioning and disposal



The unit components can be supplied to electronics and metal recycling for disposal. The manufacturer also accepts old components for disposal.

Dispose of used cleaning and rinsing media in accordance with the applicable national regulations.

13

## Manufacturer address / contact address

### Elma Hans Schmidbauer GmbH & Co. KG

Gottlieb-Daimler-Str. 17, D-78224 Singen

Phone (head office) +49 (0) 7731 / 882-0

Fax (head office) +49 (0) 7731 / 882-266

[info@elma-ultrasonic.com](mailto:info@elma-ultrasonic.com)

[www.elma-ultrasonic.com](http://www.elma-ultrasonic.com)

14

## Appendix 1: Activated carbon unit

### 14.1

### Description

The activated carbon unit consists of the base frame, the retaining bracket and 1 condensate separator and 2 activated carbon cartridges.

The base frame can be either floor-standing or wall-mounted. The condensed solvent vapours are collected in the condensate separator and must be drained regularly by the user. Suitable activated carbon granulate must be filled in the two activated carbon cartridges and changed regularly by the user.

#### Scope of delivery

Activated carbon unit, 2 fillings of activated carbon granulate, each of 500 g, funnel for filling the activated carbon cartridges, 1 set of PE filter inserts, labels for noting the maintenance, PTFE sealing tape, fastening material for optional wall mounting of the activated carbon unit.



Fire and explosion hazard!

Solvents are separated at the activated carbon unit. The instructions from *Chapter 8* of this operating manual are applicable.

Observe the applicable safety regulations for handling solvents.

Keep all kinds of ignition sources away.

Prevent ignition sparks from electrostatic discharge. Discharge possible electrostatic charges (body charge) by touching any grounded equipment before handling flammable media: e.g. water tap, metal surface of the case of the cleaning unit or use ESD protective equipment (ESD arm band).

The connected cleaning unit must not be operated during commissioning and maintenance of the activated carbon unit.

#### Disposal of used operating materials



Used operating materials must be disposed of in accordance with the regulations. No disposal via the sewer system! Dispose of used operating materials in accordance with the national disposal regulations for the media (see safety data sheet).

Used activated carbon granulate is also taken back by the supplier or its manufacturer.

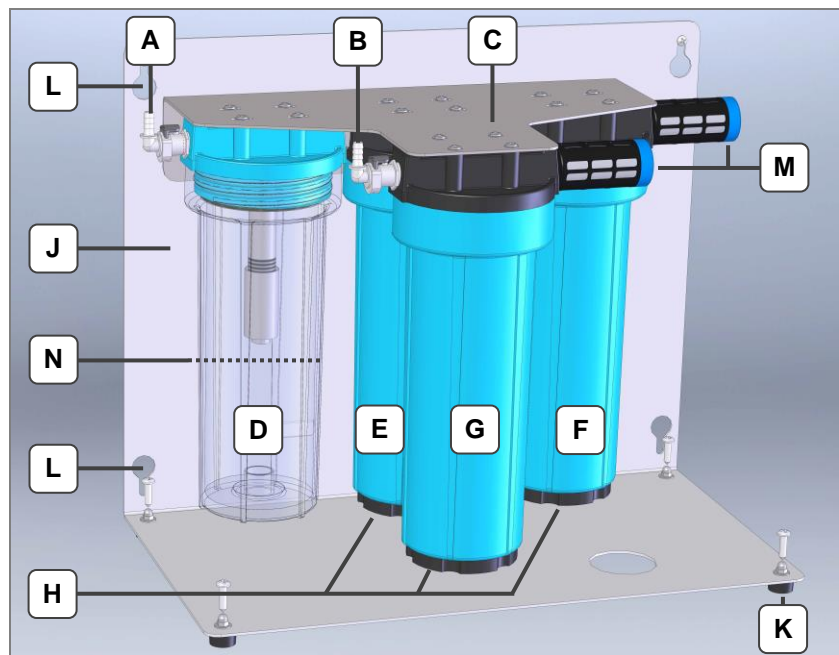

Fig. 14.1.1 Upright activated carbon unit

- A Quick coupling** for connection of the exhaust air tube for venting the cleaning chamber. In order to prevent mix-ups for the connections, this coupling has a red marking ring at the activated carbon unit and also the associated connection at the cleaning unit.
- B Quick coupling** for connection of the exhaust air tube for venting the cleaning chamber.
- C Retaining plate** attached in the base frame (**J**), detachable for emptying the condensate separator / activated carbon cartridges.
- D Condensate separator**, can be unscrewed with filter insert.
- E Activated carbon cartridge, 1st stage**
- F Activated carbon cartridge, 2st stage**
- G Activated carbon cartridge, 1nd stage**
- H Screw plug**, can be unscrewed for filling / emptying the activated carbons.
- J Base plate** enables floor-standing operation on the rubber feet (**K**) or for wall mounting (floor bracket and feet upwards) using the cut-outs (**L**).
- M PE filter** can be unscrewed for maintenance interval.
- N Maximum filling level of separated condensate** (must be below the filter in the condensate separator).

## 14.2 Filling / Installation / Commissioning

### Filling the activated carbon cartridges

The activated carbon cartridges are not filled when delivered. Proceed as follows for the filling:

Detach the retaining plate (C) from the base plate (J).

Open the screw plugs (H) of the filter cartridges and fill these using the funnel: 1 packet each of the supplied activated carbon granulate per filter cartridge.

Close the screw plugs and reattach the retaining plate.

### Installation

The base plate can either be placed on the plastic feet or wall-mounted.

Benefit for wall mounting: the condensate separator can be unscrewed for emptying without having to detach the retaining plate (Fig. 14.2.1.C) from the base plate.

For wall mounting, first fasten the base plate (floor bracket / feet upwards) using the supplied mounting material. Attach the retaining plate to the base plate (see Fig. 14.2.1).

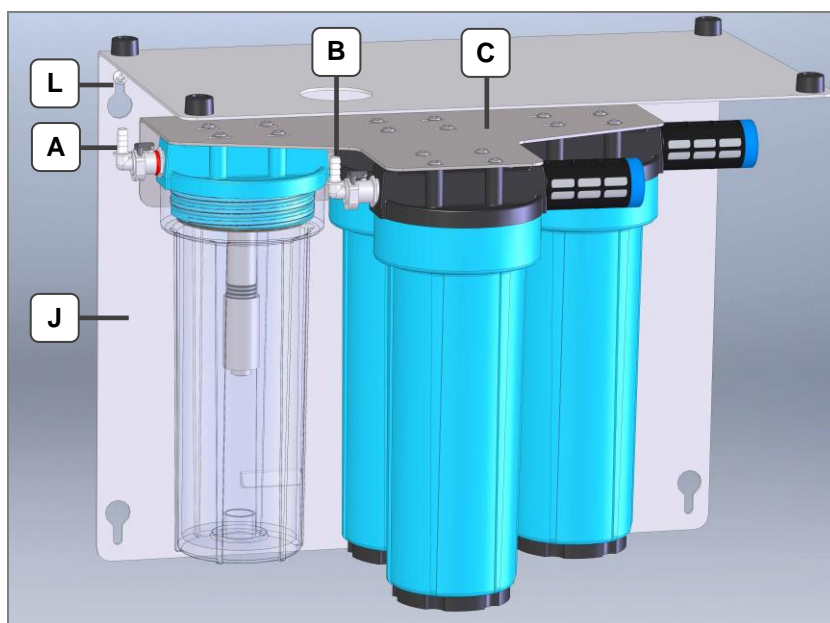

Fig. 14.2.1 Activated carbon filter in wall mounting position

### Connecting exhaust air tubes

1. Cut the exhaust air tubes included in the scope of delivery to length and put these on the quick couplings (A and B).
2. Insert the quick couplings (A and B) into the corresponding mating pieces of the activated carbon unit so that these are securely engaged.



Strictly observe the correct assignment of the two exhaust air tubes at the connections of the cleaning machine:

Connect connection **A** (red ring) of the activated carbon unit to connection **A** (red ring) of the cleaning unit (Fig. 14.2.2.A).

Connect connection **B** of the activated carbon unit to connection **B** of the cleaning unit (Fig. 14.2.2.B).

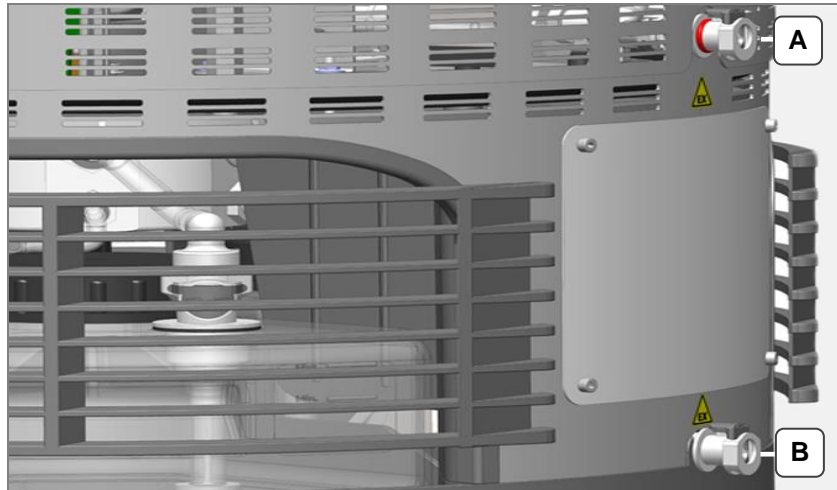

Fig. 14.2.2 Connections for venting

#### Marking label

Mark an adhesive label (included in the scope of delivery) with date and cleaning cycle (see Settings, Operating Hours) and attach it to the retaining bracket or base plate of the activated carbon unit.

### 14.3

#### Maintenance



Fire and explosion hazard!

Solvents are separated at the activated carbon unit. The instructions from *Chapter 8* of this operating manual are applicable.

Observe the applicable safety regulations for handling solvents.

### 14.3.1 Emptying condensate separator

**Interval** After view, at the latest if the filling level of the separated solvent has risen to approx. 20 mm below the filter in the condensate separator (*Fig. 14.1.1.N*).

**Procedure** Remove the retaining plate (C) with the condensate separator (D) and the activated carbon cartridges (E / F / G). In the case of wall mounting, the condensate separator can be unscrewed while the retaining bracket is attached.

Unscrew the condensate separator anticlockwise out of the holder. Ensure that you do not spill any solvent in doing so.

After emptying, screw the condensate separator back into the holder tightly.

### 14.3.2 Replacing activated carbon granulate

**Interval** The activated carbon granulate must be emptied depending on the operating conditions. It is recommended to change the activated carbons depending on the odour development. However, the activated carbons should be changed at the latest after 3 months or 150 cleaning cycles (information applies for unfavourable operating conditions: e.g. high ambient and media temperature, high proportion of drying cycles).

**Activated carbon granulate specification**

Technical requirements for activated carbons:

- Activated carbons for organic solvents
- Butane activity: 32 % (the replacement interval must be adjusted depending on the butane activity; 32% - 150 cycles, 20% - 100 cycles, ...)
- Grain size:  $\geq 2$  mm
- Free of dust

Activated carbon granulate recommended by the manufacturer:

Type: EcoSorb BX-Plus 2 mm

Manufacturer: Jacobi

Germany Sales: Overlack GmbH

**Procedure** Unclip the quick couplings (A / B) of the exhaust air tubes from the connections on the activated carbon unit.

Detach the retaining plate (C) from the base plate (J).

Open the screw plugs (*Fig. 14.1.1.H*) of the activated carbon cartridges one after the other.

Empty the used activated carbon granulate.

Place the retaining bracket with the condensate separator and the activated carbon cartridges turned over on a work surface.



Fill the required quantity of new activated carbon granulate using the funnel.

Close the screw plug.

Reattach the retaining plate to the base plate.

Mark a new label and attach it so that it is visible to the activated carbon unit.

### 14.3.3 Changing PE filter

There is a total of 5 PE filters in the activated carbon unit. The filters are available as a set and all four must be changed.

**Order number** Elma order number 105 3821

**Interval** Annually or depending on the operating conditions: If the required cleaning time gradually becomes longer and/or if an appropriate warning message is shown on the display.

**Changing outer PE filter** Unscrew the outer PE filter (Fig. 14.3.3.1.M) anticlockwise from the activated carbon cartridge.

Wrap Teflon sealing tape around the thread of the new PE filter.

Screw in the new PE filter hand tight.

**Replacing PE filter in the condensate separator** Unscrew the condensate separator (see also *Chapter 14.3.1 Emptying condensate separator*) from the holder.

Unscrew the used PE filter (Fig. 14.3.3.1.O) anticlockwise from the mounting thread.

Wrap Teflon sealing tape around the thread of the new PE filter.

Screw in the new PE filter hand tight.

Screw the condensate separator back into the holder tightly.

**Replacing PE filters in activated carbon cartridges** It is recommended to carry out the replacement of the PE filters in the activated carbon cartridges in the course of replacing the activated carbon granulate.

Detach the retaining plate (C) from the base plate (J).

Unscrew the activated carbon cartridge (see also *Chapter 14.3.2 Replacing activated carbon granulate*) from the holder.

Empty the used activated carbon granulate.

Unscrew the used PE filter (Fig. 14.3.3.1.P) anticlockwise from the mounting thread.

Wrap Teflon sealing tape around the thread of the new PE filter.

Screw in the new PE filter hand tight.

Screw the activated carbon cartridge back into the holder tightly.

Open the screw plug (Fig. 14.3.3.1.H) of the activated carbon cartridge and fill the required quantity of new activated carbon granulate using the funnel.

Close the screw plug tightly.

Reattach the retaining plate to the base plate.

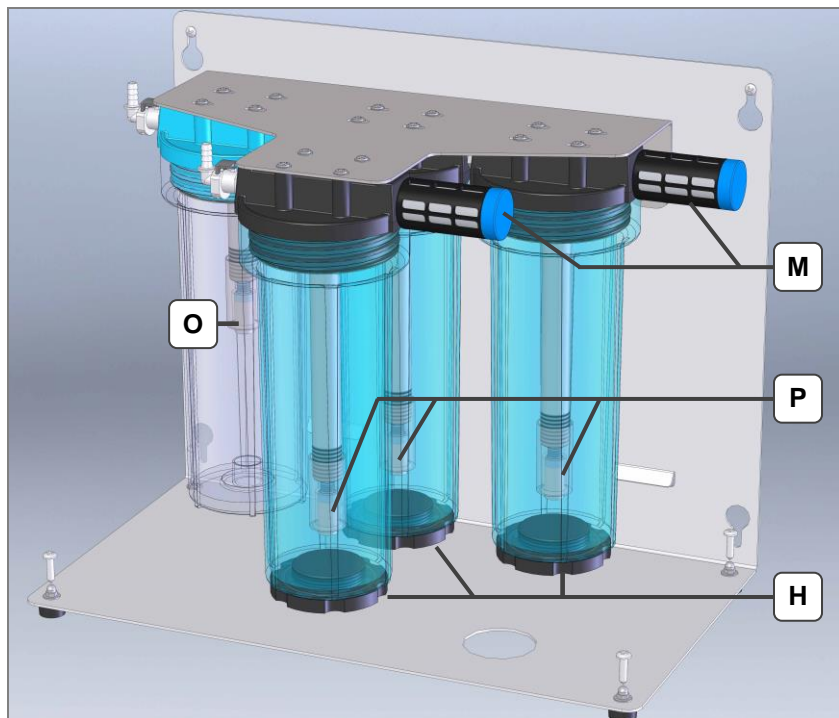

Fig. 14.3.3.1 Sectional view of activated carbon filter

## 15

## Appendix 2: Pager

The pager is a hand-held device for mobile remaining time display of the cleaning program.

As soon as a cleaning program has been started (see *Chapter 6.3 and Fig. 6.3.4*), the remaining running time of the cleaning program can be transmitted from the cleaning unit to the pager.

The distance from the cleaning unit is not relevant for displaying the remaining running time afterwards.



Fig. 15.1 Pager front / rear view

### Activating pager

1. First start the cleaning program.
2. Make the pager ready by shaking it for a short time: As soon as the green LEDs flash alternately (running light), the pager is ready for data reception for 30 seconds.
3. Hold the pager with the rear side facing the display. The sensor on the rear side of the pager (*Fig. 15.1.A*) must then be located in the range of the display.
4. Press the operating button #2 (see *Fig. 15.2.#2*). The data transmission is performed.

As soon as the LED for cleaning time on the pager lights, the data transmission is completed and the pager is activated.

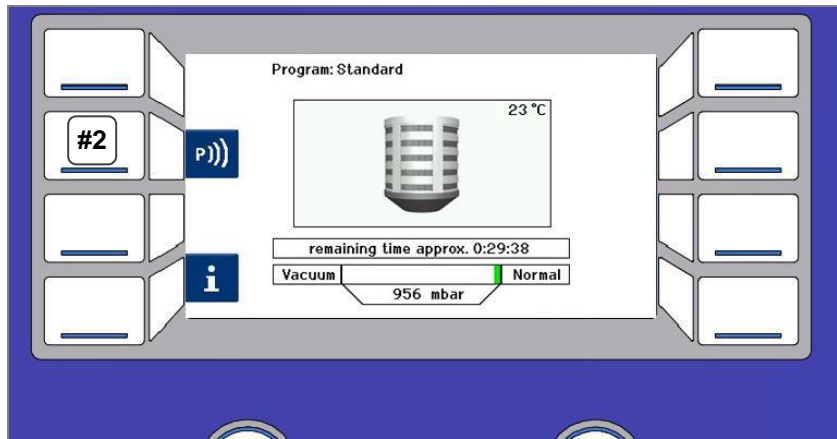

Fig. 15.2 Operating button #2

**Pager remaining time display**

The "> 15 min" LED flashes when the remaining time is less than 15 minutes.

The "~ 10 min" LED lights when the remaining time is approx. 10 minutes.

The "~ 10 min" LED flashes when the remaining time is less than 10 minutes.

The "~ 5 min" LED lights when the remaining time is approx. 5 minutes.

The "~ 5 min" LED flashes when the remaining time is less than 5 minutes.

When the cleaning process has completed, the LED *finished* lights and a vibration alarm is produced at the same time and an alarm tone afterwards. The LED is extinguished 30 seconds after the last alarm tone.

**Change battery indicator**

If the *low battery* LED lights, the batteries must be replaced.

Battery type: 2x AAA.

Rechargeable batteries with the appropriate capacity can also be used instead of batteries.

**Disposal of used batteries**



Used batteries must be disposed of in accordance with the regulations. Dispose of batteries in accordance with the national disposal regulations.