

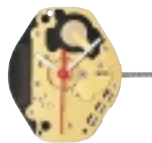

Cal. 1062  
1,90 mm



Cal. 1063  
1,90 mm



Cal. 1064  
1,90 mm  
ladies/boys



Cal. 1069  
2,30 mm  
gents

## 1. Werkdimensionen

## 1. Dimensions des mouvements

## 1. Movement dimensions

Kaliber Calibre Caliber	Ø Total	Ø Werksitz Ø Encageage Ø Case fitting	Werkhöhe Hauteur mouvement Movement height	Höhe Batterie Hauteur pile Height of battery	Höhe Stellwelle Hauteur tige Height of stem	Höhe Werkauflage Hauteur filet Movement rest
Einh./ Unité/ Unit	mm	mm	mm	mm	mm	mm
<b>1062/1063</b>	15,30 x 18,20	15,30 x 17,80	1,90	1,95	0,75	0,40
<b>1064</b>	15,30 x 18,20	15,30 x 17,80	1,90	1,95	0,75	0,40
<b>1069</b>	15,30 x 18,20	15,30 x 17,80	2,30	2,35	1,15	0,80

Stellwellengewinde/ Filetage de la tige/ Stem thread: Ø 0,90 mm Weg/ Chemin/ Length of travel: 0,35 mm

## 2. Funktionen

## 2. Fonctions

## 2. Functions

Kaliber Calibre Caliber	Stellwellenpos. Pos. de tige Stem position	Funktionen Fonctions Functions
<b>1062</b>	1	Normale Position / Position normale / Running position
	2	Zeiger stellen, mit Unterbruch der Motorimpulse Mise à l'heure, avec interruption des impulsions moteur Hand setting, with interruption of motor pulses
<b>1063</b>	1	Normale Position / Position normale / Running position
	2	Zeiger stellen, Sekunden-Stopp mit Unterbruch der Motorimpulse Mise à l'heure, stop-seconde avec interruption des impulsions moteur Hand setting, stop-second with interruption of motor pulses

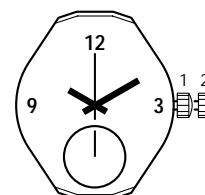
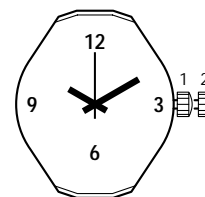

# Werkaufbau

# Assemblage

# Assembling

6 3/4 x 8''' 1062, 1063

6 3/4 x 8''' 1062, 1063

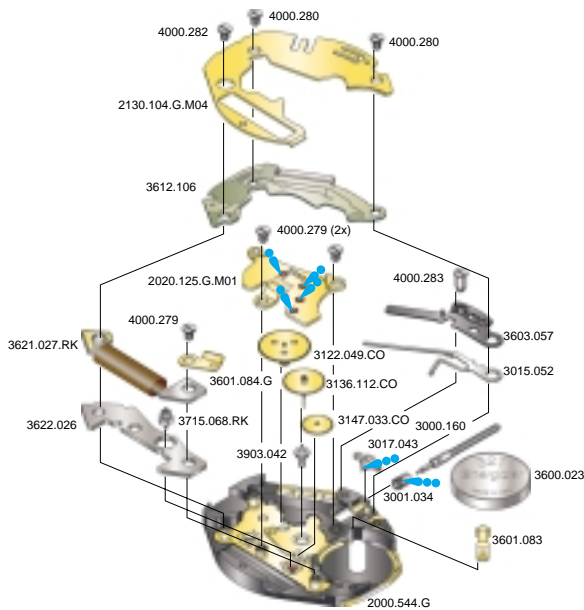

● Düninflüssiges Öl Moebius 9030  
 ●● Fett Moebius, Microgliss D5, Jismaa 124

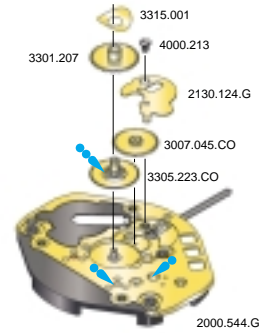

● Düninflüssiges Öl Moebius 9030  
 ●● Fett Moebius, Microgliss D5, Jismaa 124

Plan No.	Bestandteile	Fournitures	Spare Parts
2000.544.G	Werkplatte	Platine	Main plate
2020.125.G.M01	Räderwerkbrücke	Pont rouge	Train w. bridge
2130.104.G.M04	Modul-Abdeckpl.	Couvre module	Module cover pl.
3000.160	Stellwelle	Tige	Stem
3001.034	Kupplungstrieb	Pignon coulant	Sliding pinion
3015.052	Kuppl.-triebhebel	Bascule	Yoke
3017.043	Winkelhebel	Tirette	Setting lever
3122.049.CO	Kleinbodenrad	Roue moyenne	Third wheel
3136.112.CO	Sekundenrad	Roue secondes	Second-wheel
3147.033.CO	Zwischenrad	Roue interméd.	Intermed. wheel
3600.023	Batterie	Pile	Battery
3601.083	Batt.-Kontakt (-)	Bride contact (-)	Batt. contact (-)
3601.084.G	Batteriehälter (+)	Bride de pile (+)	Battery clamp (+)
3603.057	Deckplatte/Ste.	Couvre mécan.	Setting lever cov.
3612.106	Modul	Module	Module
3621.027.RK	Spule	Bobine	Coil
3622.026	Stator	Stator	Stator
3715.068.RK	Rotor	Rotor	Rotor
3903.042	Zentrumlagerrohr	Tube chaussée	Center tube
4000.279	Schraube	Vis	Screw
4000.280	Schraube	Vis	Screw
4000.282	Schraube	Vis	Screw
4000.283	Schraube	Vis	Screw

## Batterien / Piles / Batteries

1062-1069	Nr. 321 Dim.Ø x H:	SR 616 SW 6,80 x 1,65
-----------	-----------------------	--------------------------

Cal. 1063	Zifferblattseite / Côté cadran / Dial side
Plan No.	Bestandteile Fournitures Spare Parts
2130.124.G	Zeigerwerkplatte Plaque maintien Maintaining plate
3007.045.CO	Wechselrad Minuterie Minute wheel
3301.207	Stundenrad Canon Hour wheel
3305.223.CO	Minutenrohr Chaussée Cannon pinion
3315.001	Spreifeder 2 1/2 Clinquant 2 1/2 Washer 2 1/2
4000.213	Schraube Vis Screw

## Abweichungen / Divergences / Deviations

Cal. 1062	Werkseite / Côté mouvement / Movement side
Plan No.	Bestandteile Fournitures Spare Parts
2000.545.G	Werkplatte Platine Main plate
2020.124.G.M01	Räderwerkbrücke Pont rouge Train w. bridge
2130.104.G.M01	Modul-Abdeckpl. Couvre module Module cover pl.
3122.050.CO	Kleinbodenrad Roue moyenne Third wheel
3147.032.CO	Zwischenrad Roue interméd. Intermed. wheel
3612.105	Modul Module Module
3622.025	Stator Stator Stator
3715.069.RK	Rotor Rotor Rotor
3903.041	Zentrumlagerrohr Tube chaussée Center tube

Cal. 1062	Zifferblattseite / Côté cadran / Dial side
Plan No.	Bestandteile Fournitures Spare Parts
3305.222.CO	Minutenrohr Chaussée Cannon pinion

# Werkaufbau

# Assemblage

# Assembling

6 3/4 x 8''' 1064, 1069

6 3/4 x 8''' 1064

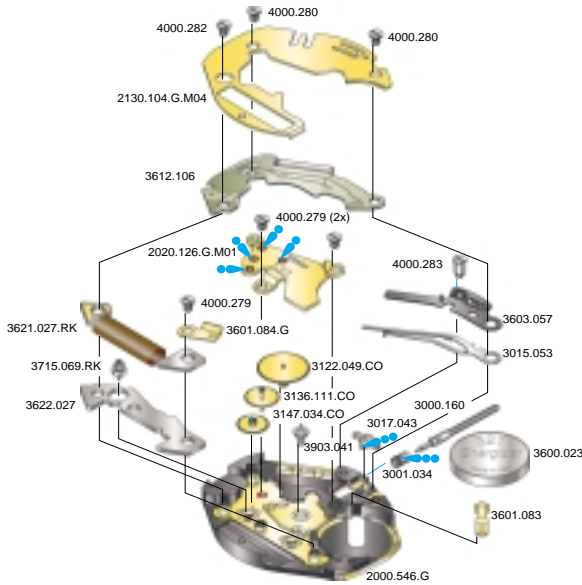

Dünnflüssiges Öl Moebius 9030  
 Fett Moebius, Microgliss D5, Jismaa 124

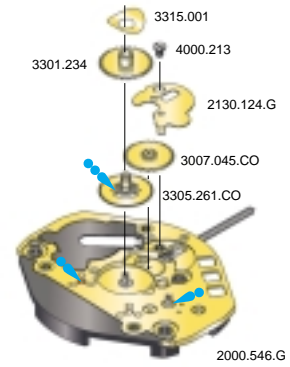

Dünnflüssiges Öl Moebius 9030  
 Fett Moebius, Microgliss D5, Jismaa 124

6 3/4 x 8''' 1069

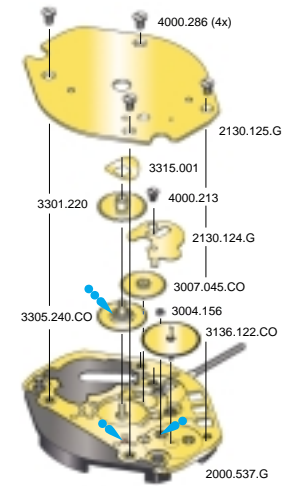

Dünnflüssiges Öl Moebius 9014  
 Fett Moebius, Microgliss D5, Jismaa

Plan No.	Bestandteile	Fournitures	Spare Parts
2000.546.G	Werkplatte	Platine	Main plate
2020.126.G.M01	Räderwerkbrücke	Pont rouge	Train w. bridge
2130.104.G.M04	Modul-Abdeckpl.	Couvre module	Module cover pl.
3000.160	Stellwelle	Tige	Stem
3001.034	Kupplungstrieb	Pignon coulant	Sliding pinion
3015.053	Kuppl.-triebhebel	Bascule	Yoke
3017.043	Winkelhebel	Tirette	Setting lever
3122.049.CO	Kleinbodenrad	Roue moyenne	Third wheel
3136.111.CO	Rad f. kl. Sek.	Roue petit sec.	Small second
3147.034.CO	Zwischenrad	Roue interméd.	Intermed. wheel
3600.023	Batterie	Pile	Battery
3601.083	Batt.-Kontakt (-)	Bride contact (-)	Batt. contact (-)
3601.084.G	Batteriehalter (+)	Bride de pile (+)	Battery clamp (+)
3603.057	Deckplatte/Ste.	Couvre mécan.	Setting lever cov.
3612.106	Modul	Module	Module
3621.027.RK	Spule	Bobine	Coil
3622.027	Stator	Stator	Stator
3715.069.RK	Rotor	Rotor	Rotor
3903.041	Zentrumlagerrohr	Tube chaussée	Center tube
4000.279	Schraube	Vis	Screw
4000.280	Schraube	Vis	Screw
4000.282	Schraube	Vis	Screw
4000.283	Schraube	Vis	Screw

## Abweichungen / Divergences / Deviations

Cal. 1069	Werkseite / Côté mouvement / Movement side		
Plan No.	Bestandteile	Fournitures	Spare Parts
2000.537.G	Werkplatte	Platine	Main plate
2020.126.G.M02	Räderwerkbrücke	Pont rouge	Train w. bridge
3136.120.CO	Rad f. kl. Sek.	Roue petit sec.	Small second
3147.038.CO	Sekundenzw.-rad	R. interméd. sec.	Sec. interm. wh.
3903.043	Zentrumlagerrohr	Tube chaussée	Center tube

Cal. 1064	Zifferblattseite / Côté cadran / Dial side		
Plan No.	Bestandteile	Fournitures	Spare Parts
2130.124.G	Zeigerwerkhaltepl.	Plaque maintien	Maintaining plate
3007.045.CO	Wechselrad	Minuterie	Minute wheel
3301.234	Stundenrad	Canon	Hour wheel
3305.261.CO	Minutenrohr	Chaussée	Cannon pinion
3315.001	Spreizfeder 2 1/2	Clinquant 2 1/2	Washer 2 1/2
4000.213	Schraube	Vis	Screw

Cal. 1069	Zifferblattseite / Côté cadran / Dial side		
Plan No.	Bestandteile	Fournitures	Spare Parts
2130.124.G	Zeigerwerkhaltepl.	Plaque maintien	Maintaining plate
2130.125.G	Obere Platte	Plaque supérieure	Superior plate
3004.156	Sek.-Mitnehmerr.	Renvoi petit sec.	Second driv. wh.
3007.045.CO	Wechselrad	Minuterie	Minute wheel
3136.122.CO	Sekundentrieb	Pignon petit sec.	Small sec. pinion
3301.220	Stundenrad	Canon	Hour wheel
3305.240.CO	Minutenrohr	Chaussée	Cannon pinion
3315.001	Spreizfeder 2 1/2	Clinquant 2 1/2	Washer 2 1/2
4000.213	Schraube	Vis	Screw
4000.286	Schraube	Vis	Screw

### 3. Leistungen

### 3. Performances

### 3. Performances

Kaliber Calibre Caliber	Bedingungen Conditions Conditions	Momentaner Gang Marche instantanée Instantaneous rate	Stromaufnahme Consommation courant Power consumption	Drehmoment Couple utile Torque	Gangreserve Autonomie Autonomy
	Einheit / Unité / Unit Typ. Wert / Valeur / Value	Mi (s/month)	I (µA)	T (µNm) sec. min.	A (Monat/mois/month)
1062	1,55 V 23°C Batt./ Pile 15 mAh	- 10/+ 20	0,32 < 0,45	- 33	64
1063/1064	1,55 V 23°C Batt./ Pile 15 mAh	- 10/+ 20	0,74 < 1,00	5,4 295	28
1069	1,55 V 23°C Batt./ Pile 15 mAh	- 10/+ 20	0,74 < 1,00	5,4 295	28
Magnetfeldabschirmung / Résist. aux champs magn. / Resist. to magnetic fields			18,8 Oe	1500 A/M	
Betriebstemperatur / Température d'opération / Operating temperature			0-50°C		Norm <b>CE</b>
Schockresistenz / Résistance au choc / Shock resistance			NIHS 91-10		

#### Anzeige Ende der Batterielaufzeit EOL

Der Sekundenzeiger hält während 4 Sekunden an und holt dann die 4 Sprünge kurzfristig nach.

#### Indication de fin de vie de pile

L'aiguille de seconde s'arrête durant 4 secondes puis fait rapidement 4 pas.

#### Battery end-of-life indication EOL

The second hand stops for 4 seconds before executing rapidly the 4 steps.

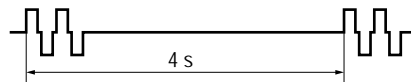

Folgende Kaliber sind mit dem EOL-System ausgerüstet:

Les calibres suivants sont munis du système EOL:

The following calibers are equipped with EOL:

Swiss Made 6<sup>3/4</sup>x8<sup>'''</sup> – 1063, 1064, 1069

### 4. Elektr. Messungen

### 4. Contrôles électriques

### 4. Electrical checking

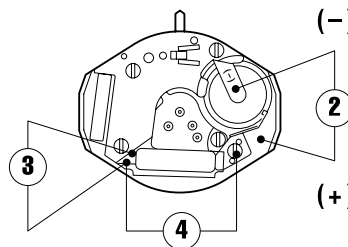
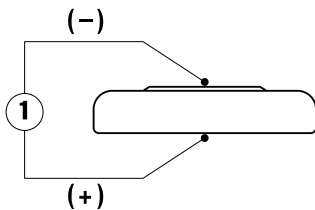

Kaliber Calibre Caliber	Pos. Pos. Pos.	Einheit Unité Unit	Messwerte Valeurs mesurées Measured values	Kontrolle Contrôle Check	Bemerkungen Remarques Remarks
1062-1069	1	V	1,55	Batterie-Spannung Tension de la pile Battery voltage	Batterie herausnehmen und messen Enlever et mesurer la pile Remove battery for measuring
1062 * by pulses	2	µA	0,32 < 0,45 < 2,40	Stromaufnahme * (Puls Periode 10 Sekunden) Consom. de courant * (impulsion 10 secondes) Power consumption * (pulse period 10 seconds)	Ohne Batterie, mit externer Speisung Sans pile, avec alimentation externe Without battery, with external power supply
1063-1069			0,74 < 1,00		
1062-1069	2	V	< 1,30	Funktionskontrolle bei Minimalspannung Contrôle de fonctionnement à tension minimale Check with lowest possible voltage	Ohne Batterie, mit externer Speisung Sans pile, avec alimentation externe Without battery, with external power supply
1062-1069	3	KΩ	2,70 < 2,90	Spulenwiderstand Résistance de la bobine Resistance of the coil	Ohne Batterie Sans pile Without battery
1062-1069	4	KΩ	∞	Spulenisolation Isolation de la bobine Coil insulation	Ohne Batterie Sans pile Without battery
1062-1069		Sek./Monat sec./mois sec./month	- 10/+ 20	Induktivsonde 60 Sek. Senseur inductif 60 sec. Inductive sensor 60 sec.	Mit Batterie Avec pile With battery

## 5. Zeigerwerk

## 5. Aiguillage

## 5. Dial-train

Kaliber Calibre Caliber	Zeigerwerk Aiguillage Height of dial train	Einzelteil-Höhe Hauteur de la pièce ind. Height of individ. piece				Höhe ab Zifferblattauflage Dépassement platine Height from base		
		mm	mm	mm	mm	mm	mm	mm
	No.	A	B	C	D	E	F	G
1062	0	1,68	0,83	–	1,12	0,90	0,60	–
	1	1,83	0,98	–	1,12	1,05	0,75	–
	2	2,03	1,18	–	1,12	1,25	0,95	–
1063	0	1,65	0,83	3,02	1,12	0,90	0,60	1,15
	1	1,80	0,98	3,22	1,12	1,05	0,75	1,35
	2	2,00	1,18	3,42	1,12	1,25	0,95	1,55
1064	0	1,68	0,83	2,12	1,12	0,90	0,60	0,25
	1	1,88	1,03	2,27	1,12	1,10	0,80	0,40
	2	2,03	1,18	2,37	1,12	1,25	0,95	0,50
1069	0	2,50	1,68	1,43	1,60	1,35	1,05	0,60
	1	2,60	1,78	1,53	1,60	1,45	1,15	0,70

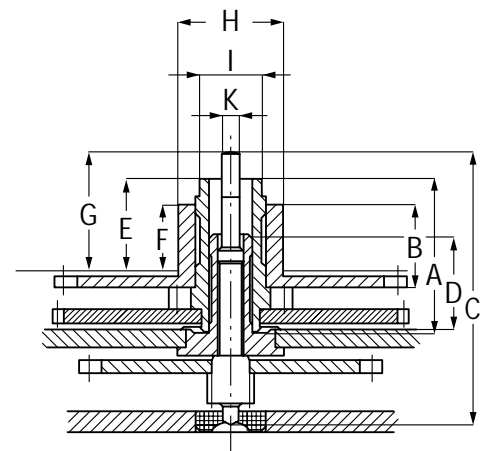
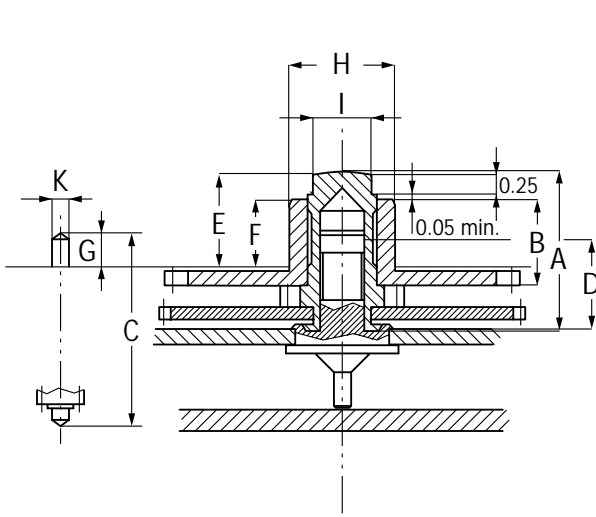

Die Zeiger dürfen nur bei zentral abgestützter Räderwerkbrücke gesetzt werden.  
Der Aufpressdruck darf 25 N (2,5 kp) nicht übersteigen.

Lors de la pose des aiguilles, le pont de rouage doit être soutenu.  
La force de chassage ne doit pas dépasser 25 N (2,5 kp).

Hands can only be set if train wheel bridge is supported by a movement holder.  
Pressure while setting hands must not exceed 25 N (2,5 kp).

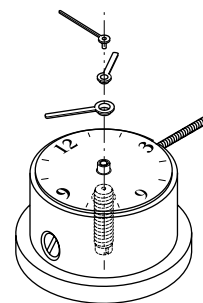

## 6. Einschalen

## 6. Emboîtage

## 6. Casing

Ø Zeigeranpassung Ø Ajustement des aiguilles Ø Adjustment of hands	mm	mm	mm
H	I	K	
1,20	0,70	0,20	

Zifferblattdicke Épaisseur du cadran Dial thickness	mm	mm
0	0,30	
1 standard	0,40	

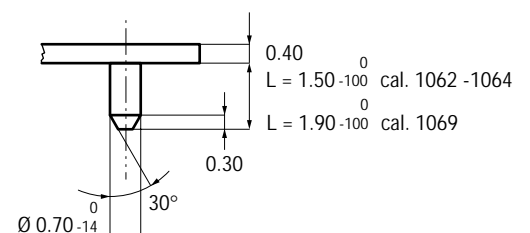

Für Einzelheiten verlangen Sie bitte die entsprechenden Zeigerwerkpläne!  
Pour plus de détails demandez nos plans d'aiguillage!  
For more detailed information please ask for the corresponding hand drawings!

Gehäuseplan  
Plan de cage  
Case drawing

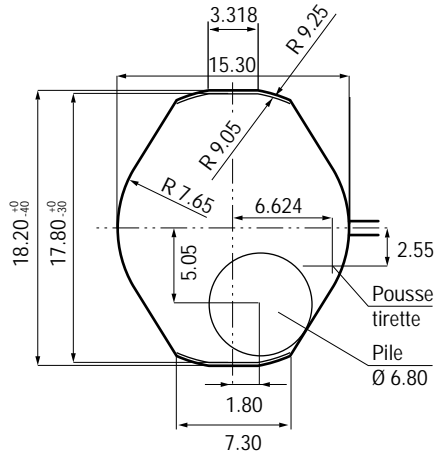
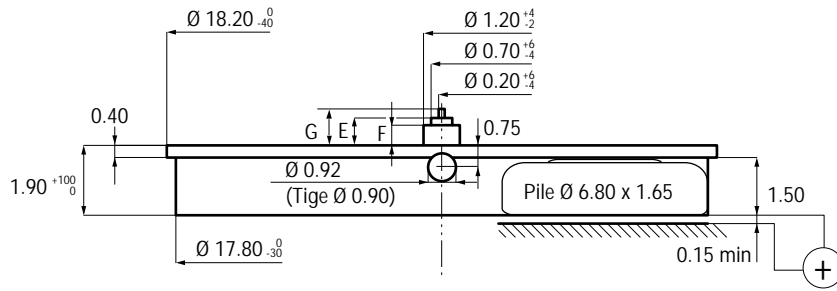

Seite gegen Gehäuseboden  
Côté fond de boîte  
Case back side

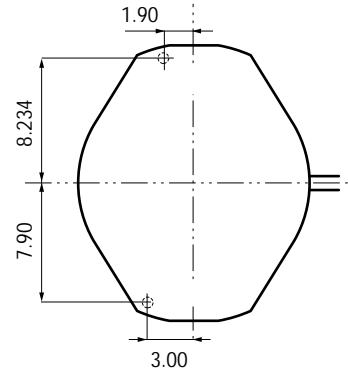

Zifferblattseite  
Côté cadran  
Dial side

Gehäuseplan  
Plan de cage  
Case drawing

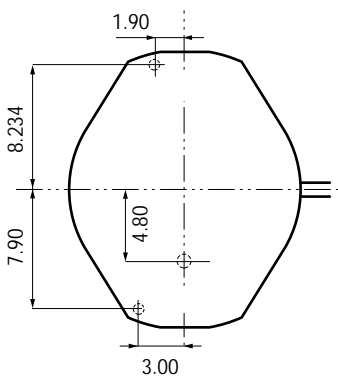
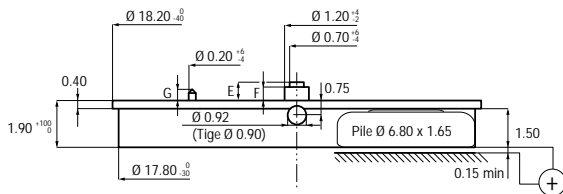

Zifferblattseite Cal. 1064  
Côté cadran  
Dial side

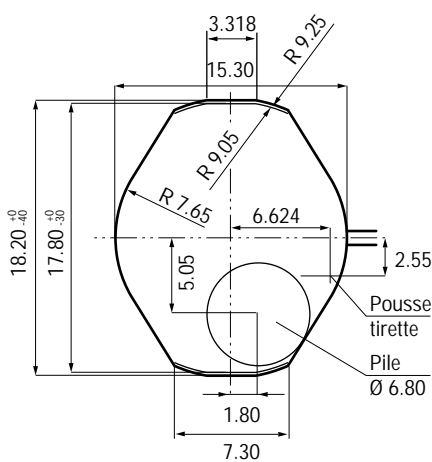
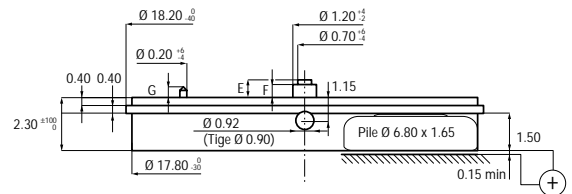

Seite gegen Gehäuseboden cal. 1064/ 1069  
Côté fond de boîte  
Case back side

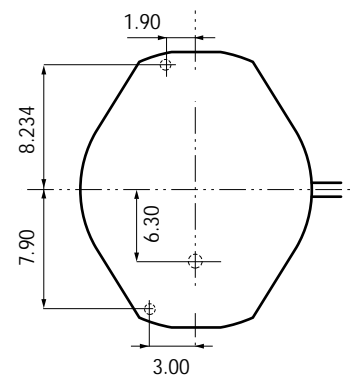

Zifferblattseite cal. 1069  
Côté cadran  
Dial side

Ajustement aiguille des heures  
Stundenzeigerpassung  
Hour hand fitting

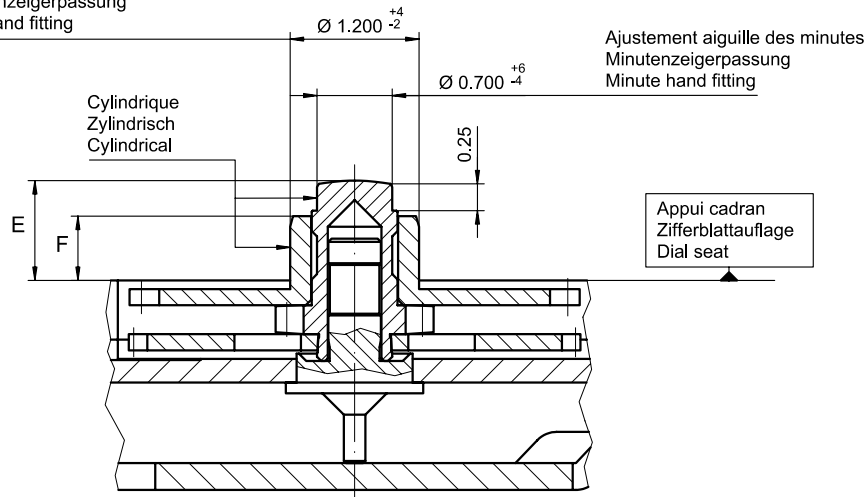

Ajustement aiguille des minutes  
Minutenzeigerpassung  
Minute hand fitting

Heures / minutes  
Stunden / Minuten  
Hours / minutes

	Aig. des minutes Minutenzeiger Minute hand	Aig. des heures Stundenzeiger Hour hand	Lors de la pose d'aiguilles, le mouvement doit être soutenu. Beim Zeigersetzen muss das Werk abgestützt werden. The movement needs to be supported for hand setting.
mg max.	30	30	Masse / Masse / Weight *
µNm max.	0.10	0.10	Balourd / Unwucht / Unbalance *
gmm <sup>2</sup> max.	-	-	Inertie / Massenträgheit / Inertia *
N max.	40	40	Force de chassage / Aufpresskraft / Force

Aiguillages Zeigerwerkhöhe Hand fitting height		
Dépassement Höhe über Zifferblattauflage Height over dial seat		
No	Chaussée Minutenrohr Cannon-pinion	Roue des heures Stundenrad Hour wheel
0	E 0.93	F 0.60
1	1.13	0.80
2	1.28	0.95

Aiguillages Zeigerwerkhöhe Hand fitting height			
Peinture comprise / inkl. Farbe / Paint included			
Epaisseur maximum du cadran Maximale Zifferblattstärke Maximum dial thickness			
No	Sous l'aiguille des minutes Unter Minutenzeiger Under minute hand	Sous l'aiguille des heures Unter Stundenzeiger Under hour hand	Epaisseur des aiguilles Zeigerstärke Hands thickness
0	0.50	0.30	0.15
1	0.70	0.40	0.15
2	0.85	0.60	0.15

Sous réserve de toutes modifications

Aenderungen vorbehalten

All modifications reserved

<b>Aiguillages Zeigerwerkhöhen Hand fitting heights</b>	<b>6 3/4 x 8'''</b>	
	<b>RONDA</b>	<b>1062</b>
	Sous réserve de modifications Aenderungen vorbehalten Modifications reserved	
	No.	3316.051
	06	

Issued	21 Feb 1996	os
Modified	01.06.2010 ÄA 2120	dh
Released	Yes	
Tolerance	µm	
Scale	20 : 1 (A3H)	

\* En cas de données différentes, veuillez contacter le service après-vente

\* Bei abweichenden Werten, bitte technischen Kundendienst anfragen

\* In case of different values, please contact the customer service

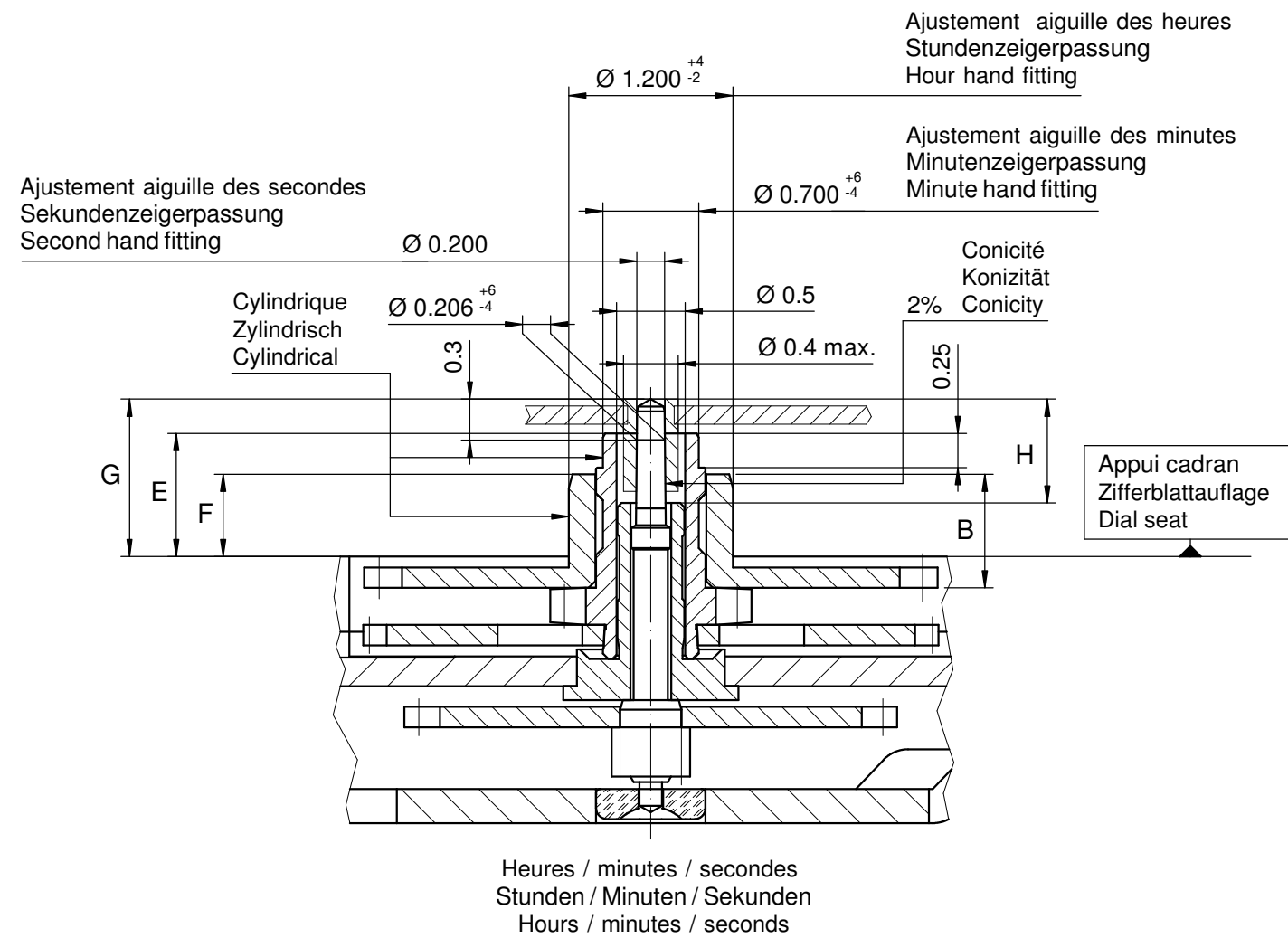

Aiguillage no Zeigerwerkhöhe Nr. Hand fitting height No	Dépassement Höhe über Zifferblattauflage Height over dial seat			Longueur Länge Length		Epaisseur max. (peinture comprise) Max. Dicke (inkl. Farbe) Max. thickness (paint included)			
	Pignon des secondes Sekundentrieb Second pinion	Chaussée Minutenrohr Cannon-pinion	Roue des heures Stundenrad Hour wheel	H	B	Cadran Zifferblatt Dial			Aiguilles Zeiger Hands
						Sous l'aiguille des secondes Unter Sekundenzeiger Under second hand	Sous l'aiguille des minutes Unter Minutenzeiger Under minute hand	Sous l'aiguille des heures Unter Stundenzeiger Under hour hand	
	G	E	F	H	B				
0	1.15	0.90	0.60	0.76	0.83	0.65	0.50	0.30	0.15
1	1.40	1.10	0.80	1.01	1.03	0.90	0.70	0.40	0.15
2	1.55	1.25	0.95	1.16	1.18	1.05	0.85	0.60	0.15

	Aig. des secondes Sekundenzeiger Second hand	Aig. des minutes Minutenzeiger Minute hand	Aig. des heures Stundenzeiger Hour hand	Lors de la pose d'aiguilles, le mouvement doit être soutenu. Beim Zeigersetzen muss das Werk abgestützt werden. The movement needs to be supported for hand setting.
mg max.	10	30	30	Masse / Masse / Weight *
µNm max.	0.04	0.60	0.60	Balourd / Unwucht / Unbalance *
gmm <sup>2</sup> max.	0.2	-	-	Inertie / Massenträgheit / Inertia *
N max.	30	40	40	Force de chassage / Aufpresskraft / Force

Sous réserve de toutes modifications

Aenderungen vorbehalten

All modifications reserved

Aiguillages Zeigerwerkhöhen Hand fitting heights		6 <sup>3</sup> / <sub>4</sub> x 8'''	
		Issued	21 Feb 1996
Modified	18 Feb 2011 ÅA 10340	ps	
Released	Yes		
Tolerance	µm		
Scale	20 : 1 (A3H)		
RONDA		1063	
Sous réserve de modifications Aenderungen vorbehalten Modifications reserved			
No.	3316.052	06	

\* En cas de données différentes, veuillez contacter le service après-vente

\* Bei abweichenden Werten, bitte technischen Kundendienst anfragen

\* In case of different values, please contact the customer service



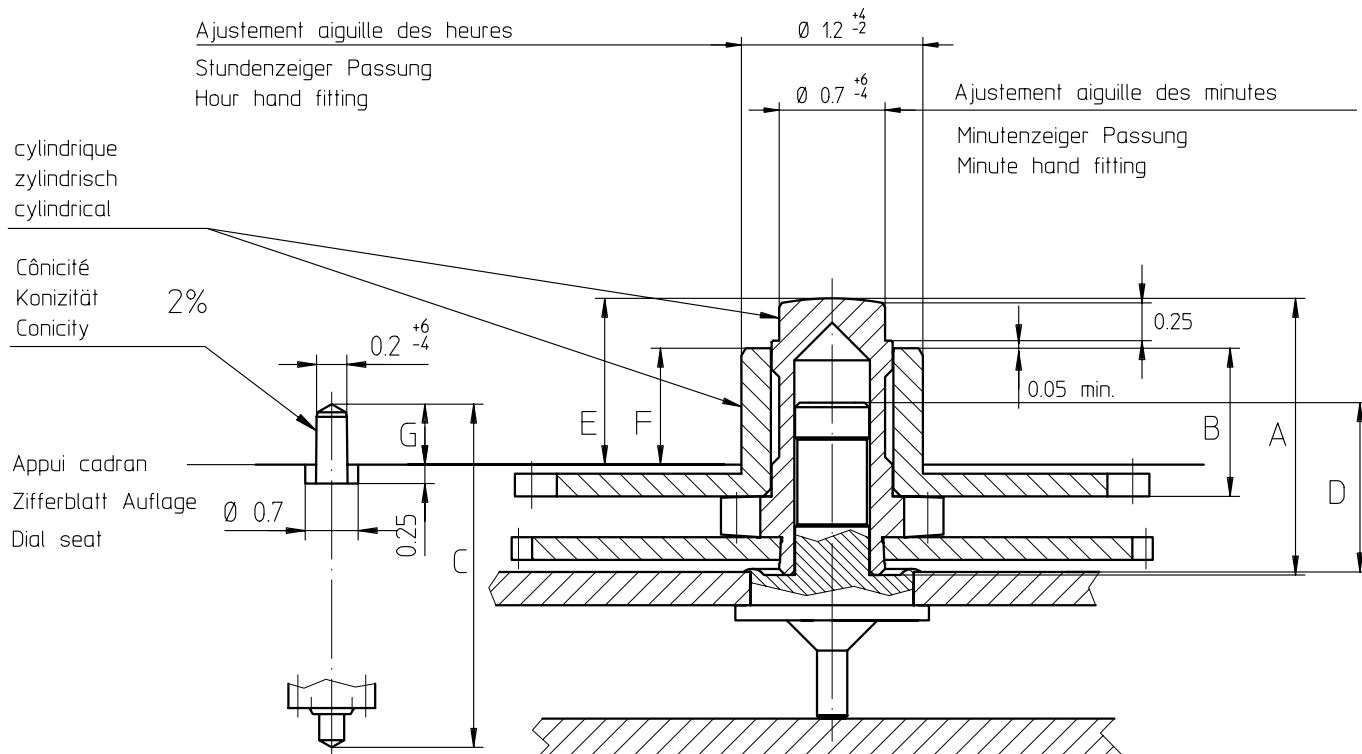

	Aiguille des sec. Sekundenzeiger Second hand	Aiguille des min. Minutenzeiger Minute hand
ép. aiguille Zeigerdicke hand thicknes	0.15mm	
balourd Unwucht unbalance	≤ 0.04 μNm	≤ 0.6 μNm
masse Masse weight	≤ 10 mg	≤ 30 mg

Aiguillage Zeigerwerk- höhe Hand fitting height	Longueur/Länge/Length				Dépassement Höhe über Zifferblattaufgabe Height over dial seat			Cadran ép. Zifferblatt- dicke Dial thiknes	Cadran ép. sous sec. Zifferblatt- dicke unter Sek. Dial thicknes under sec.
	A	B	C	D	E $\begin{smallmatrix} +100 \\ 0 \end{smallmatrix}$	F	G		
0	1.68 3305.226.C0	0.83 3301.208	2.12 3136.114.C0	1.12 3903.041	0.93	0.60	0.25	0.30 max.	0.10 max.
1	2.10 3305.261.C0	1.03 3301.234	2.27 3136.111.C0	1.12 3903.041	1.13	0.80	0.40	0.40 max.	0.20 max.
2	2.45 3305.236.C0	1.18 3301.212	2.37 3136.118.C0	1.12 3903.041	1.28	0.95	0.50	0.50 max.	0.30 max.

Aenderungen vorbehalten

Sous réserve de toutes modifications

All modifications reserved

**RONDA**

Aiguillages  
Zeigerwerkhöhen  
Hand fitting heights

Date	21 Feb 1996	os
Modifications	28.08.09 / AA 7252	ps
Checked		
Tolerance	+/- 20 μm	
Scale	20 : 1 (A4V)	

1064

No. 3316.053 09

Ajustement aiguille des heures  
Stundenzeigerpassung  
Hour hand fitting

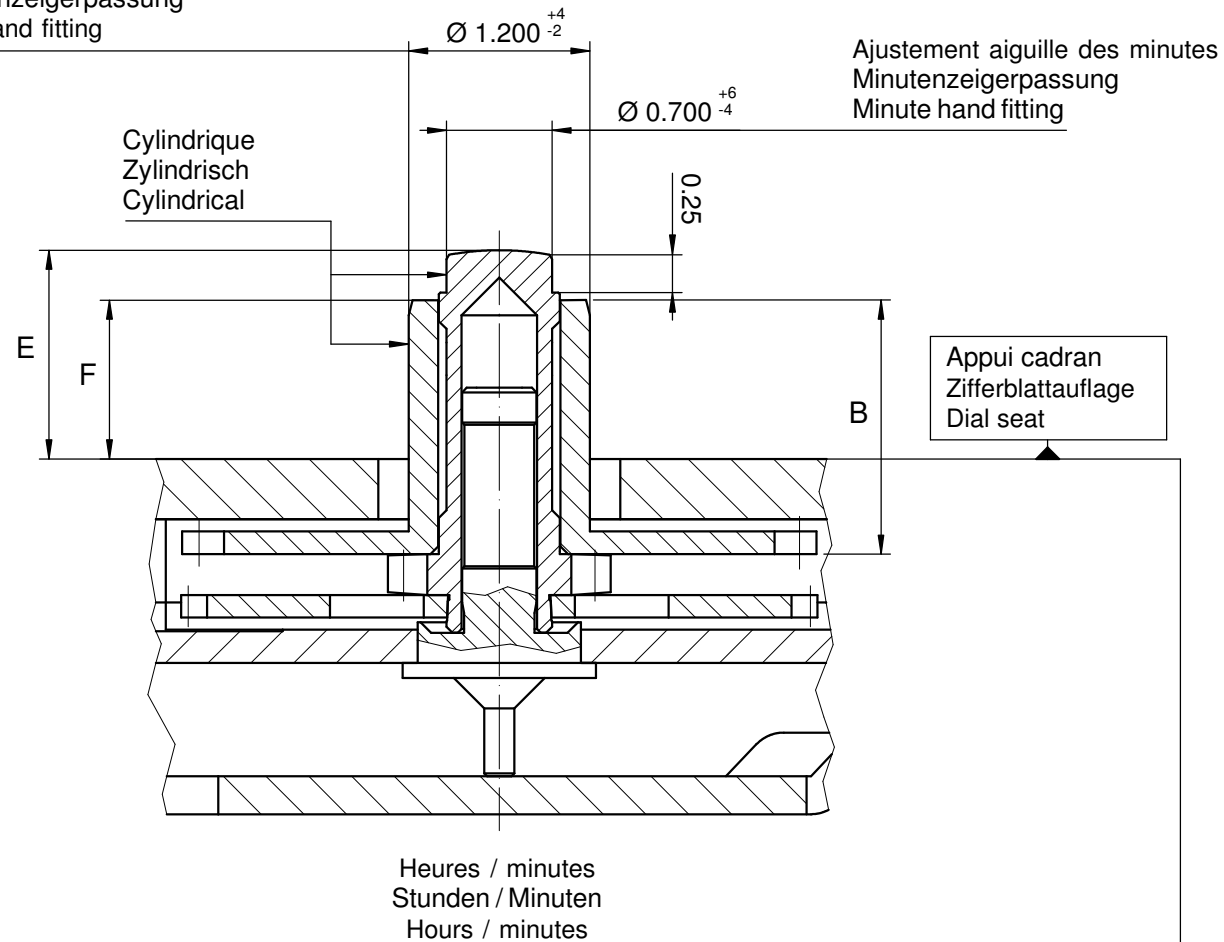

Ajustement aiguille des minutes  
Minutenzeigerpassung  
Minute hand fitting

Aiguillage no Zeigerwerkhöhe Nr. Hand fitting height No	Dépassement Höhe über Zifferblattaufgabe Height over dial seat			Longueur Länge Length		Epaisseur max. (peinture comprise) Max. Dicke (inkl. Farbe) Max. thickness (paint included)			
	Chaussée Minutenrohr Cannon-pinion	Roue des heures Stundenrad Hour wheel		Petite seconde Kleine Sekunde small seconde	Roue des heures Stundenrad Hour wheel	Cadran Zifferblatt Dial		Aiguilles Zeiger Hands	
	E	F		J	B	Sous l'aiguille des minutes Unter Minutenzeiger Under minute hand	Sous l'aiguille des heures Unter Stundenzeiger Under hour hand	Sous l'aiguille de petite seconde Unter kleine Sekundenzeiger Under small second hand	
0	1.38	1.05		0.56	1.68	0.95	0.65	0.20	0.15
1	1.48	1.15		0.66	1.78	1.05	0.75	0.30	0.15
2	1.68	1.35		0.76	1.98	1.25	0.95	0.40	0.15

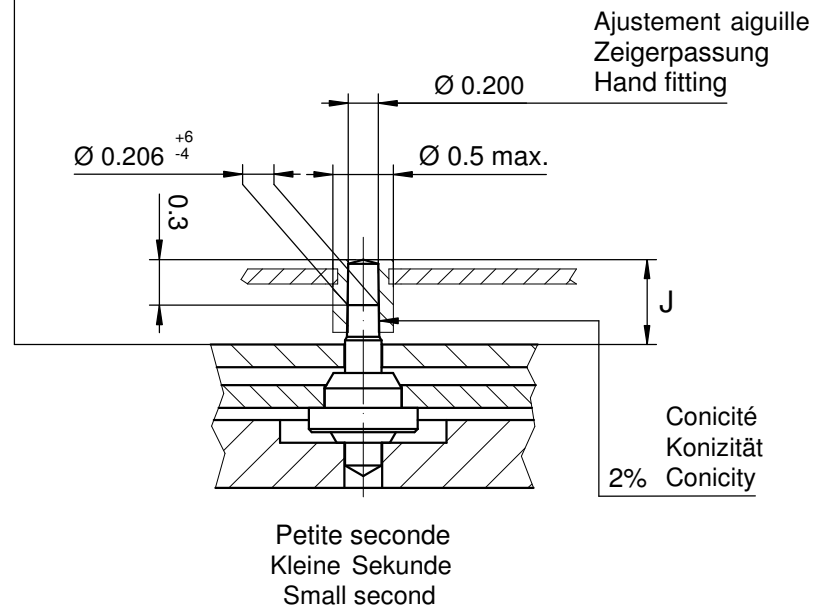

	Aig. des minutes Minutenzeiger Minute hand	Aig. des heures Stundenzeiger Hour hand	Aig. petite secondes Kleine Sekundenzeiger Small second hand	Lors de la pose d'aiguilles, le mouvement doit être soutenu. Beim Zeigersetzen muss das Werk abgestützt werden. The movement needs to be supported for hand setting.
mg max.	30	30	10	Masse / Masse / weight
µNm max.	0.60	0.60	0.04	Balourd / Unwucht / unbalance
gmm <sup>2</sup> max.	-	-	0.1	Inertie / Massenträgheit / Inertia
N max.	40	40	30	Force de chassage / Aufpresskraft / Force

Sous réserve de toutes modifications

Aenderungen vorbehalten

All modifications reserved

<b>Aiguillages Zeigerwerkhöhen Hand fitting heights</b>	6 3/4 x 8'''	
	Issued	15 Dez 1997 cs
	Modified	27 Okt 2011 dh ÅA 11646
	Released	Yes
	Tolerance	µm
Scale	20 : 1 (A3H)	
<b>RONDA 1069</b>		Sous réserve de modifications Aenderungen vorbehalten Modifications reserved
No.	3316.057	10

\* En cas de données différentes, veuillez contacter le service après-vente

\* Bei abweichenden Werten, bitte technischen Kundendienst anfragen

\* In case of different values, please contact the customer service