



11 1/2^{'''} ETA 2892A2

CT 2892A2 ESI 398773 13 20.12.2016

ETA 2892A2 for chronograph parts contact brand name on dial.

Please note: This is the non-chronograph calibre. If you movement has an add-on module or chronograph parts they are specific to the brand dial name and any parts not listed on this technical sheet are only available direct from the brand dial manufacturer. These parts are usually restricted.

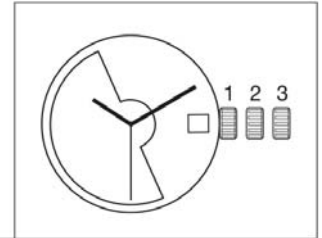

11 1/2^{'''} Ø 25,60 mm

Movement height	Altura sobre máquina	Altezza sopra movimento	3,60 mm
Running time	Reserva de marcha	Riserva di marcia	42 h
Number of jewels	Número de piedras	Numero di pietre	21
Angle lift of balance	Ángulo de alzamiento	Angolo di alzamento	51°
Frequency	Frecuencia	Frequenza	28'800 A/h

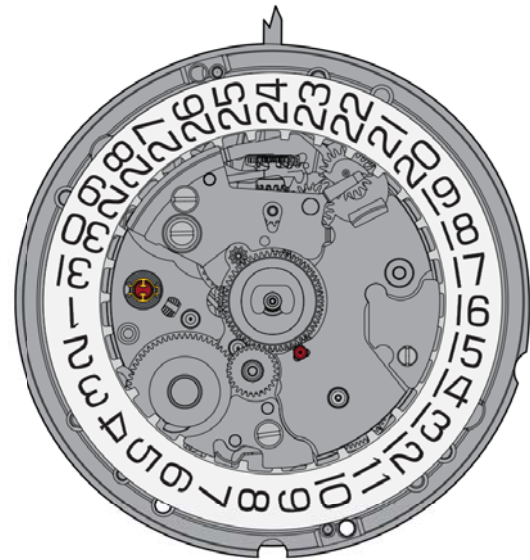
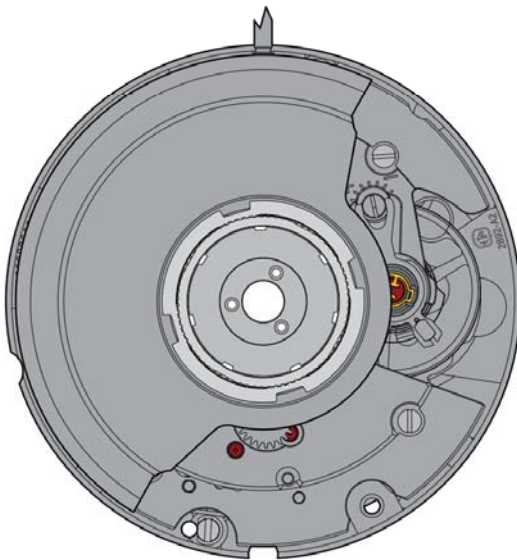

The repair and reconditioning work must only be performed by properly trained personnel.
Las tareas de reparación y revisión sólo deben ser llevadas a cabo por personal debidamente formado.
I lavori di riparazione e di revisione devono essere eseguiti esclusivamente da personale adeguatamente formato.



General information



Before starting work, please study this "Technical communication" carefully.



Eye protection is obligatory for all operations / work on the movement!



ETA SA disclaims any liability in case of damage arising from failure to observe this "Technical communication".

Environmental protection requirements



The legal provisions relating to waste handling and disposal must be observed in all operations / work on the movement!

In particular, lubricating and cleaning products harmful to the environment must be disposed of in accordance with the rules!



Substances prone to cause water pollution must be stored, transported, collected and disposed of in appropriate vessels.

They must not pollute the soil or be poured into sewage systems!

Explanation of symbols



Caution! Risk of material damage!

Below are some obligatory instructions for preventing any material damage!



Below are some application tips and important informations.

Información general



Esta "Comunicación técnica" deberá estudiarse muy bien **antes** de comenzar los trabajos.



Es obligatorio utilizar protección ocular para todos los trabajos en y con el reloj.



ETA SA no se hace responsable de los daños provocados como consecuencia de la inobservancia de esta "Comunicación técnica".

Normas de protección medioambiental



Deberá cumplirse la normativa legal relativa al reciclaje y la eliminación correctos de los residuos en todos los trabajos en y con el reloj.

En especial, deberán eliminarse correctamente los productos lubricantes y de limpieza peligrosos para el medio ambiente.



Las sustancias contaminantes del agua deben recogerse, almacenarse, transportarse y eliminarse en recipientes adecuados.

En ningún caso se permitirá que contaminen el suelo o que lleguen a la canalización.

Significado de los símbolos



Atención Peligro de daños materiales

Instrucciones que deberán respetarse necesariamente para evitar daños materiales.



Consejos de aplicación e información importantes.

Informazioni generali



Questa "Comunicazione Tecnica" deve essere studiata attentamente **prima** dell'inizio dei lavori.



Per tutti i lavori su e con il movimento dell'orologio è obbligatorio proteggere gli occhi!



ETA SA declina qualunque responsabilità per eventuali danni causati dalla mancata osservanza della presente "Comunicazione tecnica".

Disposizioni relative alla protezione ambientale



Per tutti i lavori su e con il movimento dell'orologio si dovranno rispettare le disposizioni di legge relative al corretto riciclaggio e smaltimento dei rifiuti!

In particolare si dovrà provvedere al corretto smaltimento di lubrificanti e detergenti nocivi per l'ambiente!



Le sostanze inquinanti per l'acqua devono essere conservate, trasportate, raccolte e smaltite in contenitori adatti.

Queste non devono inquinare il terreno o arrivare nelle canalizzazioni!

Spiegazione dei simboli



Attenzione! Pericolo di danni materiali!

Seguono importanti indicazioni che devono essere tassativamente rispettate per evitare danni materiali!



Seguono consigli per l'uso e informazioni importanti.

List of components - Lista de piezas - Lista fornitori

Pos	Article number Número de artículo Numero articolo		List of components	Lista de piezas	Lista fornitori
1	Var		Main plate, assembled	Platina, montada	Piastra montata
1-1	Var	2x	Dial fastener	Sujetador del cuadrante	Ferma-quadrante
1-2	7613226049185		Jewelled shock-absorber, for balance, shouldered, to press in, bottom INCABLOC	Amortiguador empedrado, de volante, de embutir, de asiento, debajo INCABLOC	Ammortizzatore con pietra, del bilanciere, a pressione, con piano di appoggio, sotto INCABLOC
2	7613226032835		Sliding pinion	Piñón corredizo	Pignone scorrevole
3	7613226058095		Winding pinion	Piñón de remontuar	Pignone di carica
4	Var		Winding stem	Tija de remontuar	Albero di carica
5	7613226001183		Date corrector operating lever	Mando del corrector de fecha	Commando del correttore della data
6	7613226029569		Setting lever	Tirete	Tiretto
7	7613226046504		Yoke	Báscula de piñón corredizo	Bascula del pignone scorrevole
8	7613226018693		Setting lever jumper, 3 functions	Muelle flexible de tirete, 3 funcio- nes	Scatto del tiretto, 3 funzioni
9	7613226044517		Escape wheel	Rueda de escape	Ruota di scappamento
10	7613226045804		Third wheel	Rueda primera	Ruota mediana
11	Var		Second wheel	Rueda de segundos	Ruota dei secondi
12	Var		Train wheel bridge, jewelled	Puente de rodaje, empedrado	Ponte del ruotismo con pietre
13	7613226036789		Intermediate wheel	Rueda intermedia	Ruota intermedia
14	Var		Barrel complete	Cubo completo	Bariletto completo
15	7613226003187		Ratchet wheel	Rochete	Rocchetto
16	Var		Barrel bridge, assembled	Puente de cubo, montado	Ponte del bariletto, montato
16-1	Var		Barrel bridge, jewelled	Puente de cubo, empedrado	Ponte del bariletto, con pietre
16-2	7613226055636		Crown wheel	Rueda de corona	Ruota a corona
16-3	7613226028807		Intermediate crown wheel	Rueda de corona intermedia	Ruota della corona intermedia
16-4	7613226006706		Intermediate ratchet wheel, assembled	Rochete intermedio, montado	Rocchetto intermedio, montato
16-5	7613226039612		Click plate	Placa de trinquete	Placca del cricco
16-6	Var		Countersunk head screw	Tornillo de cabeza cónica	Vite a testa conica
16-7	7613226008533		Click	Trinquete	Cricco
16-8	Var		Ratchet wheel driving wheel	Rueda de arrastre de rochete	Ruota conduttrice del rocchetto
17	7613226017214		Pallet fork	Áncora	Ancora
18	Var		Pallet bridge, jewelled	Puente de áncora, empedrado	Ponte dell'ancora, con pietre
19	Var		Timed balance regulated chronometer	Bilanciere regolato cronometro	Volante regulado cronometro
20	Var		Balance bridge, assembled	Puente de volante, montado	Ponte del bilanciere, montato
20-1	Var		Balance bridge	Puente de volante	Ponte del bilanciere
20-2	7613226010697		Regulator corrector	Corrector de raqueta	Correttore della racchetta
20-3	7613226029767		Stud support	Porta-pitón	Porta-pitone
20-4	7613226026148		Lower index, assembled	Raqueta inferior ajustada	Racchetta inferiore montata
20-5	7613226000803		Upper index	Raqueta superior	Racchetta superiore
20-6	7613226021136		Jewelled shock-absorber,for balance, shouldered, to press in, top INCABLOC	Amortiguador empedrado, de volante, de embutir, de asiento, encima INCABLOC	Ammortizzatore con pietra, del bilanciere, a pressione, con piano di appoggio, sopra INCABLOC
21	Var		Automatic device framework, jewelled	Marco del dispositivo automático, empe- drado	Gabbia del dispositivo automatico, con pietre
22	7613226056862		Intermediate reduction wheel, jewelled	Rueda intermedia de reducción, empe- drada	Ruota intermedia di riduzione, con pietre
23	7613226048324		Reduction wheel	Rueda de reducción	Ruota di riduzione
24	7613226005457		Reversing wheel	Rueda de inversión	Ruota d'inversione
25	7613226051331		Reverser, assembled	Inversor, montado	Invertitore, montato
26	Var		Automatic device lower bridge, jewelled	Puente inferior del dispositivo automático, empedrado	Ponte inferiore del dispositivo automatico, con pietre
27	7613226018167		Auxiliary reverser	Inversor auxiliar	Invertitore ausiliario
28	Var		Oscillating weight, assembled	Masa oscilante, montada	Massa oscillante, montata
28-1	Var		Oscillating weight	Masa oscilante	Massa oscillante
28-2	Var		Ball bearing	Rodamiento de bolillas	Cuscinetto a sfere
28-3	Var		Oscillating weight bolt	Cerrojito de rueda de reducción	Paletto della massa oscillante
29	7613226010222		Stop lever	Palanquita-stop	Leva stop
30	7613226027312		Setting wheel	Rueda de transmisión	Rinvio
31	7613226057067		Intermediate setting wheel	Rueda de transmisión intermedia	Rinvio intermedio
32	7613226021297		Date corrector, assembled	Corrector de fecha, montado	Correttore della data, montato
33	Var		Cannon pinion with driving wheel	Cañón de minutos con arrastrador	Pignone caizante con conduttore
34	Var		Minute wheel, assembled	Rueda de minutería, montada	Ruota della minuteria, montata
35	7643226036710		Minute train bridge	Puente de rodaje de minutería	Ponte del ruotismo di minuteria
36	Var		Date indicator	Indicador de fecha	Indicatore della data

Pos	Article number Número de artículo Numero articolo	List of components	Lista de piezas	Lista fornitori
37	7613226014053	Date indicator driving wheel	Rueda de arrastre del indicador de fecha	Ruota conduttrice dell'indicatore della data
38	7613226016040	Date jumper	Muelle flexible de fecha	Scatta-data
39	7613226035102	Intermediate date wheel	Rueda intermedia de fecha	Ruota intermedia del datario
40	7613226057739	Date jumper maintaining plate	Placa de sujeción del muelle flexible de fecha	Placca di guardia dello scatta-data
41	7613226035065	Additional indicator maintaining small plate	Plaqueta suplementaria de sujeción del indicador	Placchetta supplementare di guardia dell'indicatore
42	Var	Hour wheel, assembled	Rueda de horas, montada	Ruota delle ore, montata
43	7613226021778	Key-bolt	Chaveta	Chiavetta
900	Var	Countersunk head screw 1x - Pos. 8: Screw for setting lever jumper 3x - Pos. 16: Screw for barell bridge 1x - Pos. 18: Screw for pallet bridge 1x - Pos. 20: Screw for balance bridge 1x - Pos. 26: Screw for automatic device lower bridge 1x - Pos. 35: Screw for minute train bridge 1x - Pos. 40: Screw for date indicator maintaining plate	Tornillo de cabeza cónica - Pos. 8: Tornillo para muelle flexible de tirete - Pos. 16: Tornillo para el puente de cubo - Pos. 18: Tornillo para el puente de áncora - Pos. 20: Tornillo para el puente de volante - Pos. 26: Tornillo del puente inferior para dispositivo automático - Pos. 35: Tornillo para puente de rodaje de minutería - Pos. 40: Tornillo para placa de sujeción del muelle flexible de fecha	Vite a testa conica - Pos. 8: Vite per scatto del tiretto - Pos. 16: Vite per ponte barilletto - Pos. 18: Vite per ponte ancora - Pos. 20: Vite per ponte bilanciere volante - Pos. 26: Vite per ponte inferiore del dispositivo automatico - Pos. 35: Vite per ponte del ruotismo di minuteria - Pos. 40: Tornillo per placca di guardia dello scatta-data
901	Var	Collar screw 1x - Pos. 12: Screw for train wheel bridge	Tornillo collarete - Pos. 12: Tornillo para puente de rodaje	Vite flangia - Pos. 12: Vite per ponte ruotismo
902	Var	Countersunk head screw 1x - Pos. 16-5: Screw for clickplate 3x - Pos. 28-2: Screw for ball bearing	Tornillo de cabeza cónica - Pos. 16-5: Tornillo para placa de trinquete - Pos. 28-2: Tornillo para rodamiento de bolillas	Vite a testa conica - Pos. 16-5: Vite per placca del cricco - Pos. 28-2: Vite per cuscinetto a sfere
903	Var	Countersunk head screw 3x - Pos. 21: Screw for automatic device lower bridge	Tornillo de cabeza cónica - Pos. 21: Tornillo del puente inferior para dispositivo automático	Vite a testa conica - Pos. 21: Vite per ponte inferiore del dispositivo automatico
904	Var	Countersunk head screw 1x - Pos. 41: Screw for additional indicator maintaining small plate	Tornillo de cabeza cónica - Pos. 41: Tornillo para plaqueta suplementaria de sujeción del indicador	Vite a testa conica - Pos. 41: Placchetta supplementare di guardia dell'indicatore
	Var	Variant	Variante	Variante

**Interchangeability and variants
can be found on the
ETA ONLINE SHOP (EOS):**

www.eta.ch

- Customer Service
- Customer Service Portal

**La intercambiabilidad y las
variantes se encuentran en
ETA ONLINE SHOP (EOS):**

www.eta.ch

- Customer Service
- Customer Service Portal

**L'intercambiabilità e le varianti si
trovano sul
ETA ONLINE SHOP (EOS):**

www.eta.ch

- Customer Service
- Customer Service Portal

Materials - Fornituras - Forniture

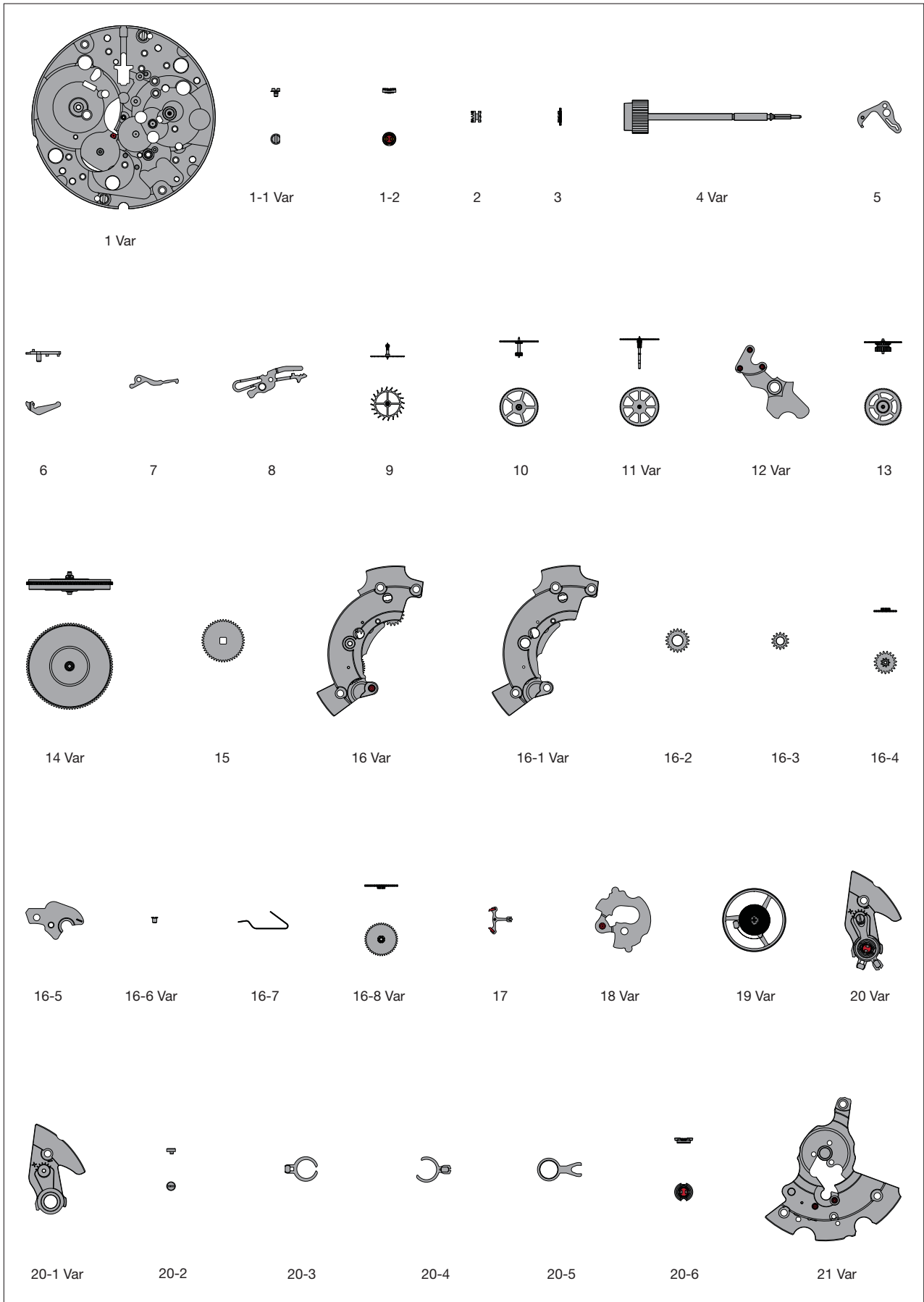

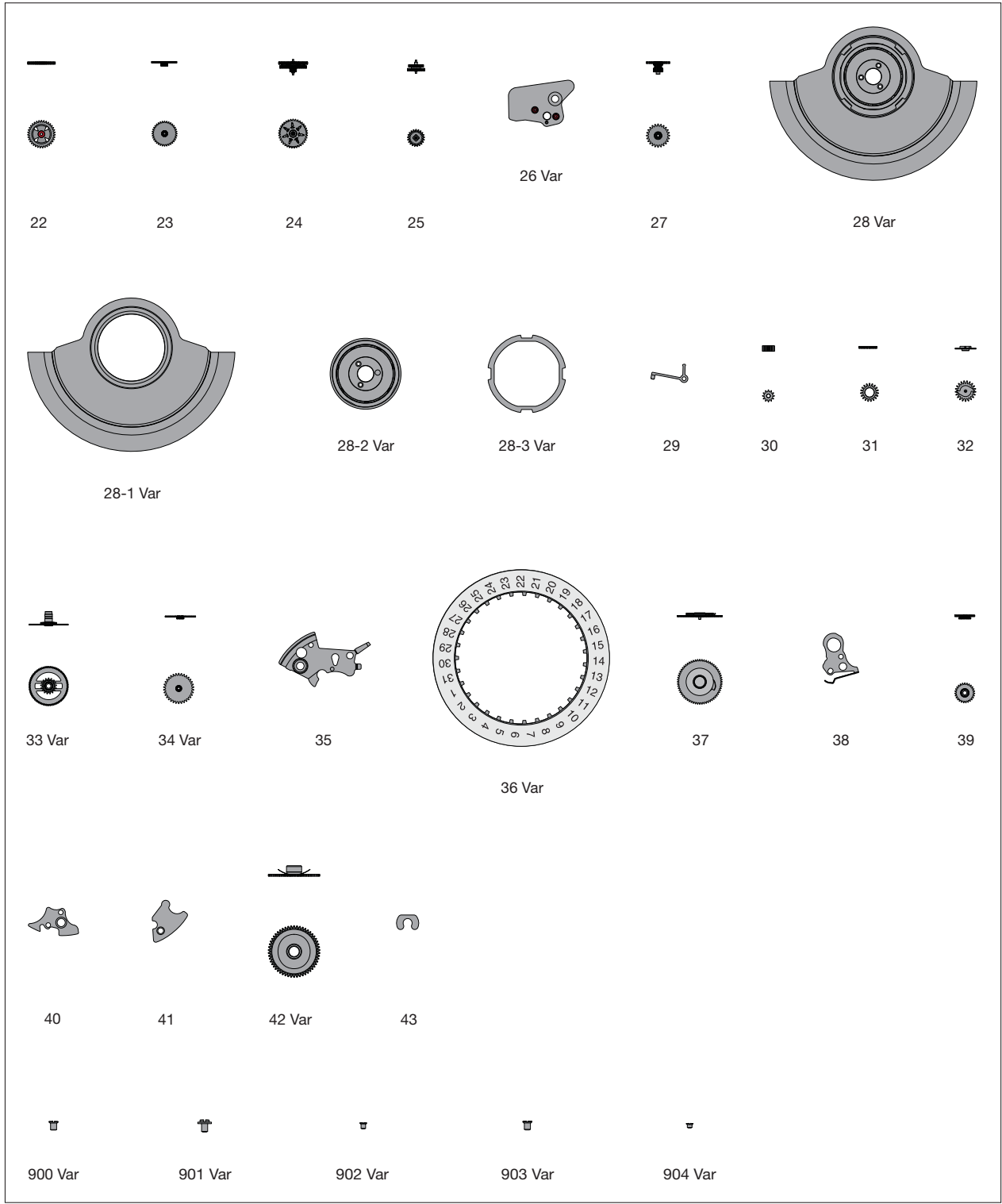

Order of assembly - Orden del montaje - Ordine dell'assemblaggio:
 Hand-setting mechanism - Mecanismo de puesta en hora - Meccanismo della messa all'ora

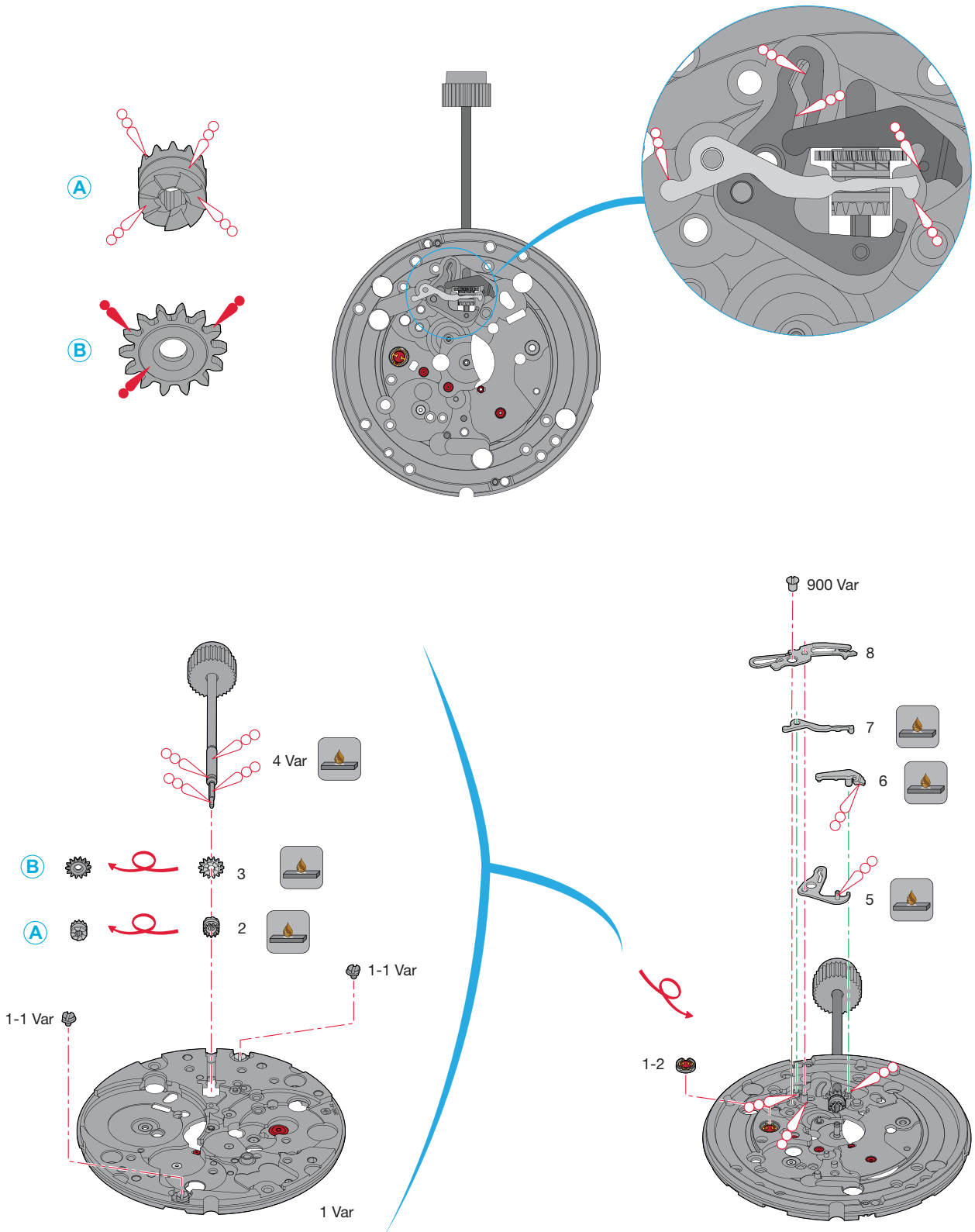

Assembling of the handsetting mechanism

(Parts listed in order of assembly)

Montaje del mecanismo de puesta en hora

(Lista de fornitureas por orden de ensamblado)

Montaggio del meccanismo della messa all'ora

(Elenco delle forniture in ordine di montaggio)

1 Var	7	
2	8	
3	900 (1x)	
4 Var		
5		
6		

Lubrication - Lubricación - Lubrificazione

 Thick oil
Aceite espeso
Olio denso

**Moebius
HP-1300**

 Grease
Grasa
Grasso

**Moebius
9504**



If the pieces to be assembled are not new, existing components must be treated with Moebius Fixodrop ES/BS 8981 epilame before reassembly.

Si las piezas por ensamblar no son nuevas, los componentes existentes deben ser tratados con el Moebius Fixodrop ES/BS 8981.

Se non vengono montati dei nuovi pezzi, i componenti esistenti devono essere trattati prima del rimontaggio con Moebius Fixodrop ES/BS 8981.

Moebius Fixodrop ES/BS 8981



Volatile
volátil
Volatile

Very volatile product!

Keep in closed and airtight containers after usage.

Producto muy volátil!

Para su uso posterior, mantener cerrados en recipientes herméticos.

Prodotto molto volatile!

Da conservare dopo l'uso in recipienti ermeticamente chiusi.

Order of assembly - Orden del montaje - Ordine dell'assemblaggio:
Basic movement - Máquina de base - Movimento di base

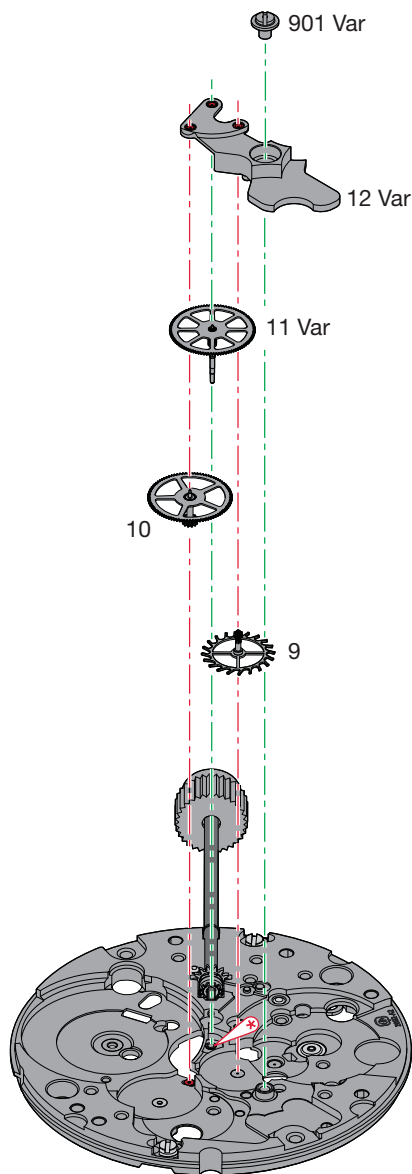
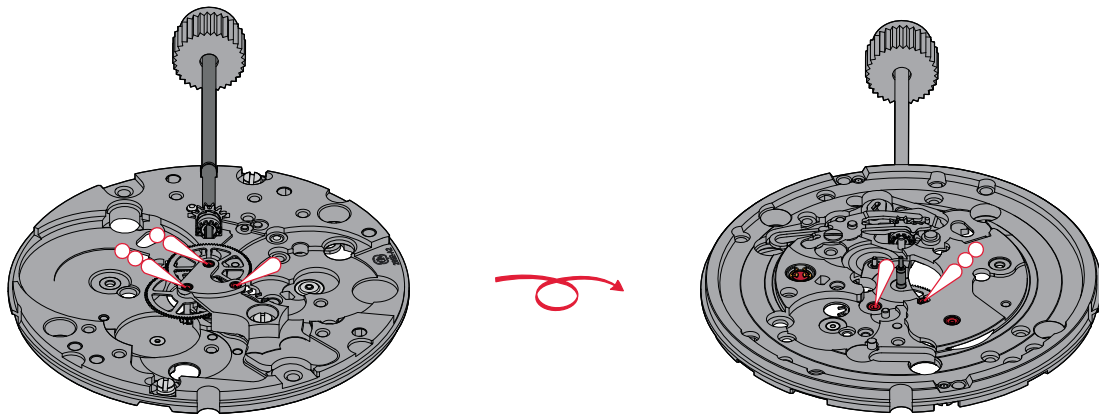

Assembling of the basic movement

(Parts listed in order of assembly)

Montaje de la máquina de base

(Lista de fornitureas por orden de ensamblado)

Montaggio del movimento di base

(Elenco delle forniture in ordine di montaggio)

9	901 (1x)	
10		
11 Var		
12 Var		

Lubrication - Lubricación - Lubrificazione

 Fine oil
 Aceite fino
 Olio fluido

Moebius 9010

 Very small quantity
 Cantidad muy pequeña
 Piccolissima quantità

Moebius 9010



 Medium oil
 Aceite medio
 Olio medio

**Moebius
HP-500**

 Thick oil
 Aceite espeso
 Olio denso

**Moebius
HP-1300**

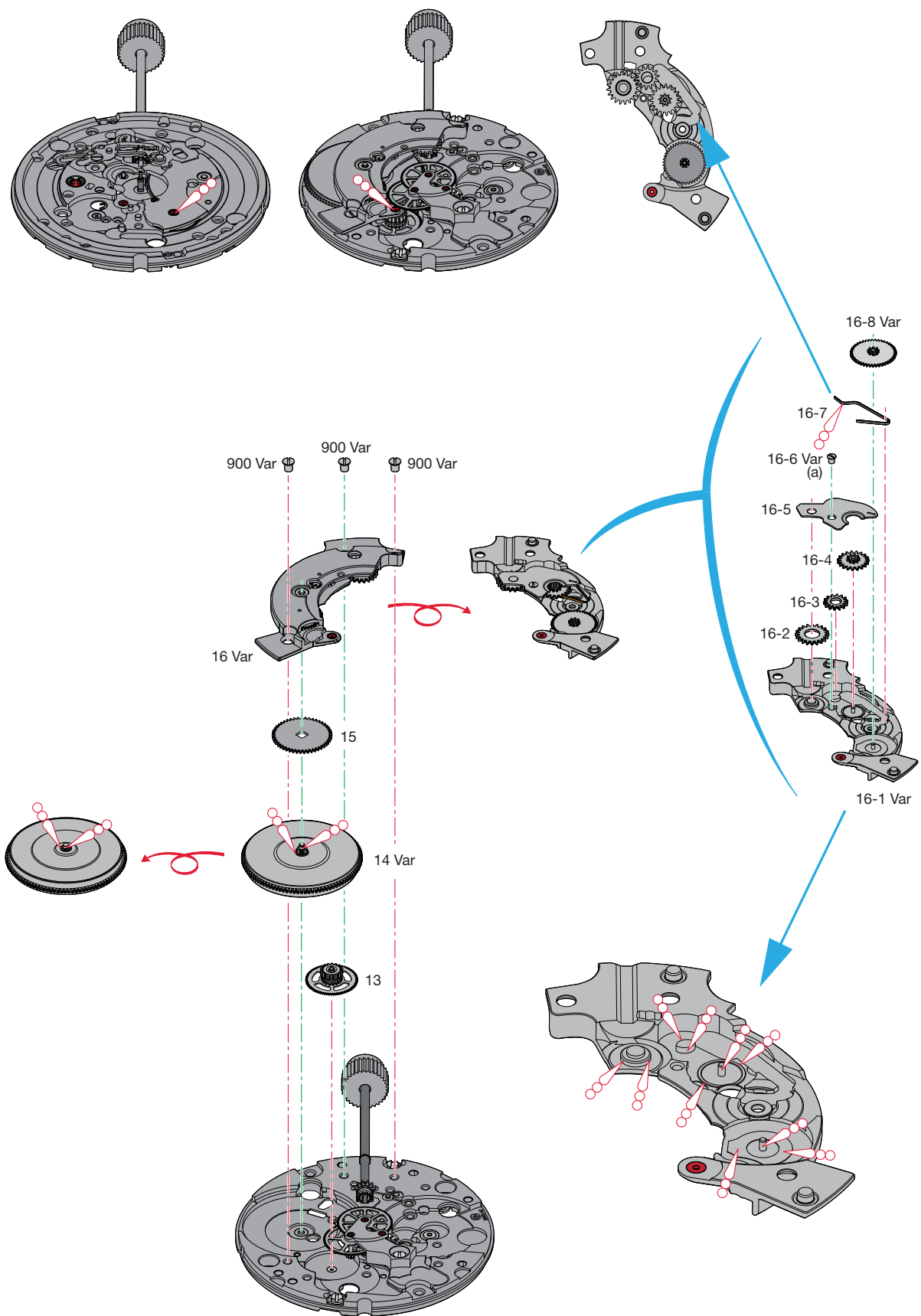
Order of assembly - Orden del montaje - Ordine dell'assemblaggio:
 Basic movement - Máquina de base - Movimento di base



Assembling of the basic movement

(Parts listed in order of assembly)

Montaje de la máquina de base

(Lista de fornitureas por orden de ensamblado)

Montaggio del movimento di base

(Elenco delle forniture in ordine di montaggio)

13	900 (3x)	
14 Var		
15		
16 Var		

Lubrication - Lubricación - Lubrificazione

Thick oil
Aceite espeso
Olio denso

**Moebius
HP-1300**

Order of assembly - Orden del montaje - Ordine dell'assemblaggio:
 Basic movement - Máquina de base - Movimento di base

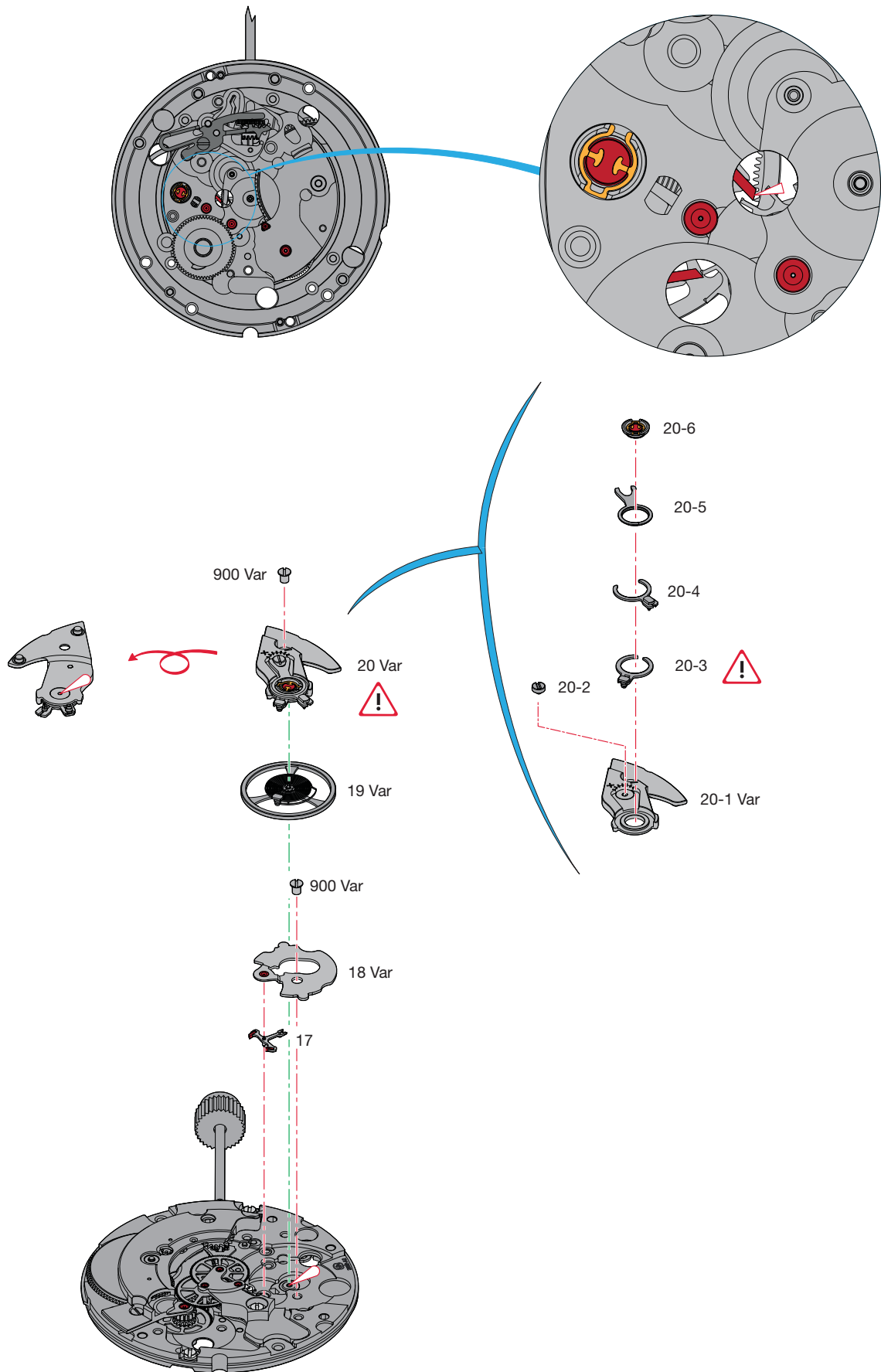

Assembling of the basic movement

(Parts listed in order of assembly)

Montaje de la máquina de base

(Lista de fornituras por orden de ensamblado)

Montaggio del movimento di base

(Elenco delle forniture in ordine di montaggio)

17	20 Var	
18 Var	900 (1x)	
900 (1x)		
19 Var		

Lubrication - Lubricación - Lubrificazione

 Fine oil
 Aceite fino **Moebius 9010**
 Olio fluido

 Special oil for pallet stones
 Aceite especial para escape **Moebius 9415**
 Olio speciale per scappamento

**Delivery:**

- Stud support, assembled
- Timed balance with stud

Assembly:

- Use only 1x the stud

Entrega:

- Porta-pitón, montada
- Volante regulado con pitón

Montaje:

- Utilizar solo una vez el pitón!

Consegna:

- Porta-pitone, montata
- Bilanciere regolato con pitone

Assemblaggio:

- Utilizzare il porta-pitone 1 sola volta!

Order of assembly - Orden del montaje - Ordine dell'assemblaggio:
 Self-winding mechanism - Mecanismo automático - Meccanismo automatico

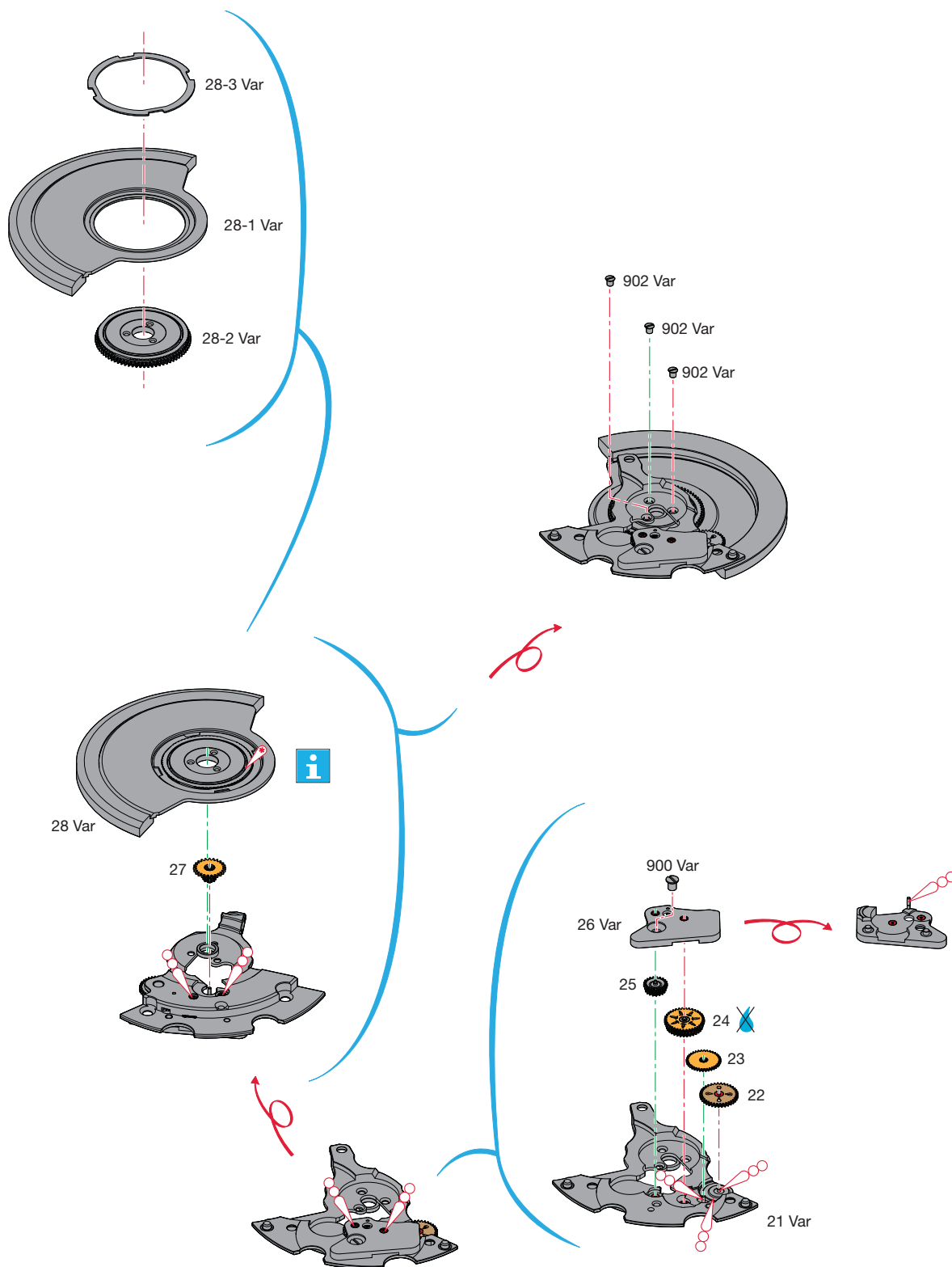

Assembling of the self-winding mechanism

(Parts listed in order of assembly)

Montaje del mecanismo automático

(Lista de fornitureas por orden de ensamblado)

Montaggio del meccanismo automatico

(Elenco delle forniture in ordine di montaggio)

21 Var	26 Var
22	900 (1x)
23	27
24	28 Var
25	902 (3x)

Lubrication - Lubricación - Lubrificazione

Very small quantity



Cantidad muy pequeña
Piccolissima quantità

Moebius 9010

Thick oil



Aceite espeso
Olio denso

**Moebius
HP-1300**

Do not wash. If the part is very dirty or rusty, it should be exchanged for an original part which is lubricated and delivered by ETA SA.



Na lavar. Si la pieza está muy sucia o herrumbrosa, cambiar por una fornitura de origen entregada lubrificada por ETA SA.

Non lavare. Se il pezzo è molto sporco arrugginito, sostituire con una fornitura di origine fornita lubrificata da ETA SA.

Pos. 28 Var:



Only after the washing, use a very small quantity of Moebius 9010.

Solo después de lavar, muy pequeña cantidad moebius 9010.

Solamente dopo il lavaggio piccolissima quantità di Moebius 9010.

Order of assembly - Orden del montaje - Ordine dell'assemblaggio:
Self-winding mechanism - Mecanismo automático - Meccanismo automatico

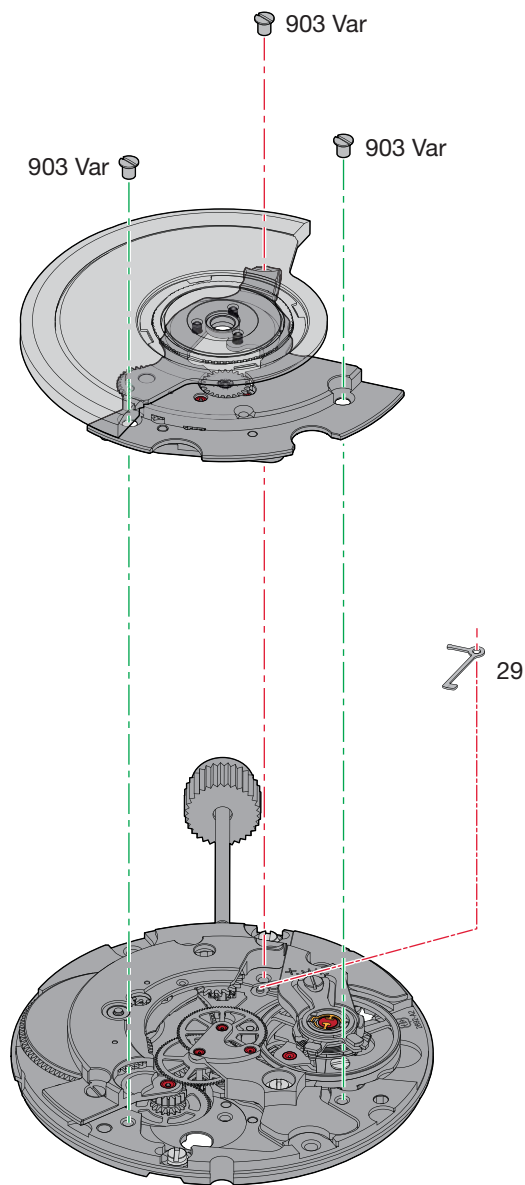

Assembling of the self-winding mechanism

(Parts listed in order of assembly)

Montaje del mecanismo automático

(Lista de fornitureas por orden de ensamblado)

Montaggio del meccanismo automatico

(Elenco delle forniture in ordine di montaggio)

29

903 (3x)

Order of assembly - Orden del montaje - Ordine dell'assemblaggio:
 Calendar mechanism - Mecanismo de calendario - Meccanismo del calendario

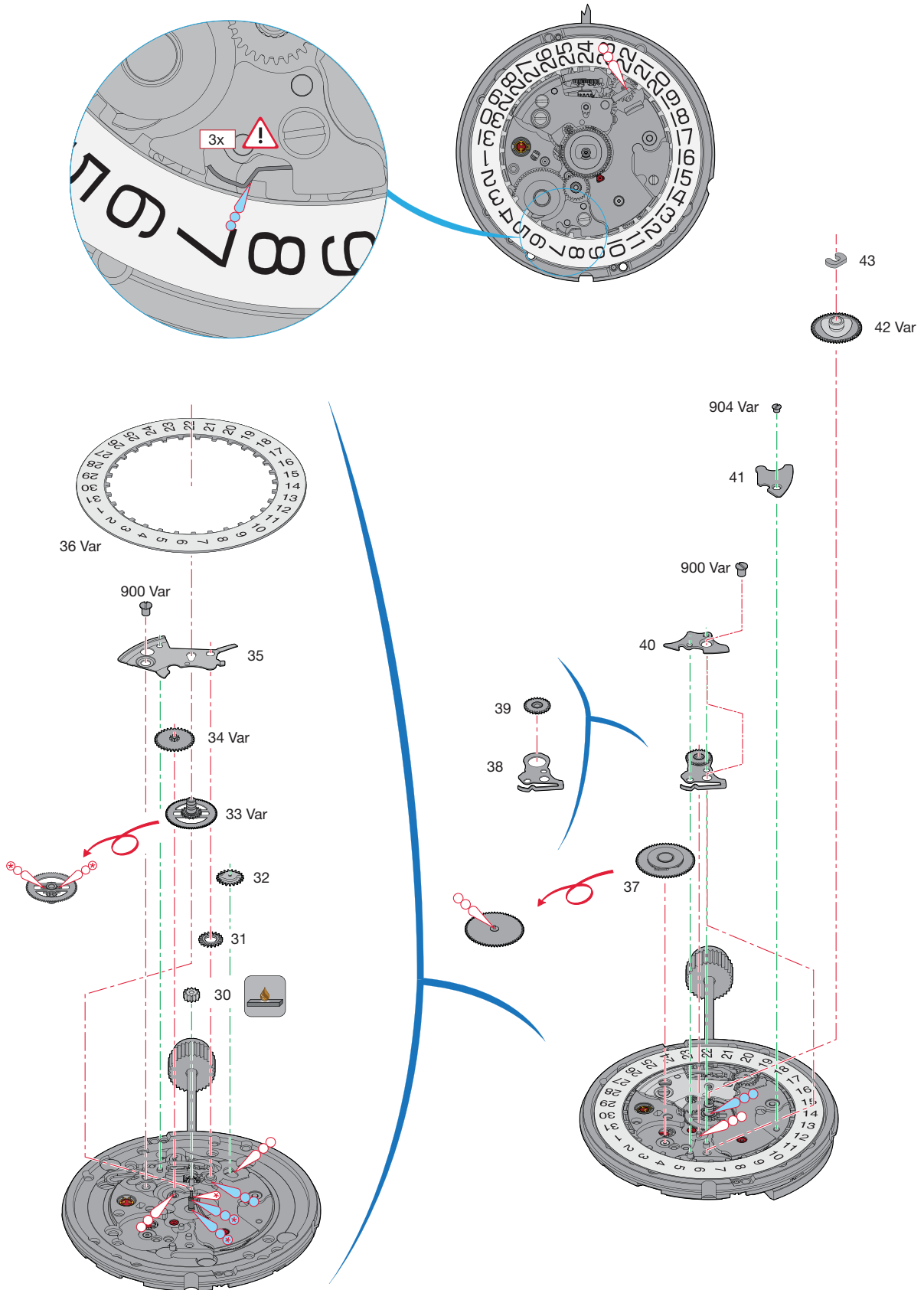

Assembling of the calendar mechanism

(Parts listed in order of assembly)

Montaje del mecanismo de calendario

(Lista de fornitureas por orden de ensamblado)

Montaggio del meccanismo del calendario

(Elenco delle forniture in ordine di montaggio)

31	36 Var	41
32	37	904 (1x)
33 Var	38	42 Var
34 Var	39	43
35	40	
900 (1x)	900 (1x)	

Lubrication - Lubricación - Lubrificazione

	Thick oil Aceite espeso Olio denso	Moebius HP-1300
	Very small quantity Cantidad muy pequeña Piccolissima quantità	Moebius HP-1300
	Thick oil Aceite espeso Olio denso	Moebius HP-1300 SC
	Very small quantity Cantidad muy pequeña Piccolissima quantità	Moebius HP-1300 SC
	Very small quantity Cantidad muy pequeña Piccolissima quantità	Moebius 9010

If the pieces to be assembled are not new, existing components must be treated with Moebius Fixodrop ES/BS 8981 epilame before reassembly.

Si las piezas por ensamblar no son nuevas, los componentes existentes deben ser tratados con el Moebius Fixodrop ES/BS 8981.

Se non vengono montati dei nuovi pezzi, i componenti esistenti devono essere trattati prima del rimontaggio con Moebius Fixodrop ES/BS 8981.



Lubricate part 38.

1. Lubrique la pieza 38.
Lubrificare il pezzo 38.

2. Rotate part 36 approx 10 teeth with rapide correction.
Gire la pieza 36 unos 10 dientes con la corrección rápida.
Ruotare il pezzo 36 di circa 10 denti con la correzione rapida.

3. Lubricate again part 38.
Lubrique de nuevo la pieza 38.
Lubrificare di nuovo il pezzo 38.

4. Rotate part 36 approx 10 teeth with rapide correction again.
Gire de nuevo la pieza 36 unos 10 dientes con la corrección rápida.
Ruotare di nuovo il pezzo 36 di circa 10 denti con la correzione rapida.

5. Lubricate again part 38.
Lubrique de nuevo la pieza 38.
Lubrificare di nuovo il pezzo 38.

6. Rotate part 36 approx 10 teeth with rapide correction again.
Gire de nuevo la pieza 36 unos 10 dientes con la corrección rápida.
Ruotare di nuovo il pezzo 36 di circa 10 denti con la correzione rapida.



Moebius Fixodrop ES/BS 8981



Volatile
volátil
Volatile

Very volatile product!

Keep in closed and airtight containers after usage.

Producto muy volátil!

Para su uso posterior, mantener cerrados en recipientes herméticos.

Prodotto molto volatile!

Da conservare dopo l'uso in recipienti ermeticamente chiusi.



For information regarding hand fitting heights see:

Manufacturing Information

Drawing:
AIGUILLAGES
ZEIGERWERKHÖHEN
HAND FITTING HEIGHTS



Para obtener información sobre las alturas de la minutería, consulte:

Información de la producción

Plan:
AIGUILLAGES
ZEIGERWERKHÖHEN
HAND FITTING HEIGHTS



Per informazioni concernenti l'aggiustamento lancette, consultare:

Informazione di produzione

Disegno:
AIGUILLAGES
ZEIGERWERKHÖHEN
HAND FITTING HEIGHTS

This page has deliberately been left blank in case of A3 format printing.

Esta página se han dejado en blanco a propósito en caso de imprimirla en formato A3.

Questa pagina è lasciata intenzionalmente bianca in caso di stampa formato A3.

Modifications compared with previous document versions**Modificaciones comparadas con las versiones anteriores del documento****Modifiche comparate con le versioni precedenti del documento**

Version Versión Versione	Date Fecha Data	Modification	Modificación	Modifica	Page Página Pagina
13	20.12.2016	Nouvelle illustration pos. 10	Neue Illustration Pos. 10	New illustration pos. 10	6, 10
12.1	29.08.2016	Modifications lubrications	Modificaciones lubricaciones	Modifica lubrificazione	9-21
12	29.08.2016	Intern error / invalid version	Error interno / versión inválida	Errore interno / versione non valida	--
11	19.04.2016	Corrections page	Correcciones pagina	Correzioni a pagina	1, 3-5, 12, 14
10.1	23.02.2015	Text correction	Corrección texto	Correzione testo	22
10	07.10.2014	Montage	Montaje	Montaggio	10
09	18.11.2013	Montage	Montaje	Montaggio	3-21
08	27.10.2010	Montage	Montaje	Montaggio	6-13
07	10.05.2010	Addition Variant list of components	Adición Variante lista de piezas	Aggiunta Variante lista fornitori	3
		Lubrication	Lubrificación	Lubrificazione	6-11
06	16.02.2010	Remove parts No 714, 728 and 730	Eliminar piezas No. 714, 728 y 730	Soppressione degli pezzi No 714, 728 e 730	2, 5
05	02.02.2009	Remove parts No 166 and 166/1	Eliminar piezas No. 166 y 166/1	Soppressione degli pezzi No 166 e 166/1	2
		Minimum torque for loosening	Par mínimo para desatornillar	Coppia minima per svitare	5-7
		New drawing	Nuevo plan	Disegno nuovo	8
		New logos	Nuevas logos	Nuovi logos	1, 12
		New layout	Nuevo layout	Nuova layout	1-12
04	01.10.2004	Basic version	Versión de base	Versione di base	--

All modifications reserved.

Salvo modificación.

Con riserva di ogni eventuale modifica.

This document can be found on the
Customer Service Portal (CSP):

www.eta.ch

- Customer Service
- Customer Service Portal
- Technical Documents

Este documento se encuentran en el
Customer Service Portal (CSP):

www.eta.ch

- Customer Service
- Customer Service Portal
- Technical Documents

Il presente documento si trovano sul
Customer Service Portal (CSP):

www.eta.ch

- Customer Service
- Customer Service Portal
- Technical Documents



ETA^{SA}
MANUFACTURE HORLOGÈRE SUISSE
DEPUIS 1793

SC MARKETING & COMMUNICATION

Bahnhofstrasse 9
2540 Grenchen
Switzerland

Phone +41 (0)32 655 71 11
Fax +41 (0)32 655 71 74

contact@eta.ch
www.eta.ch