

Fig. 1.0

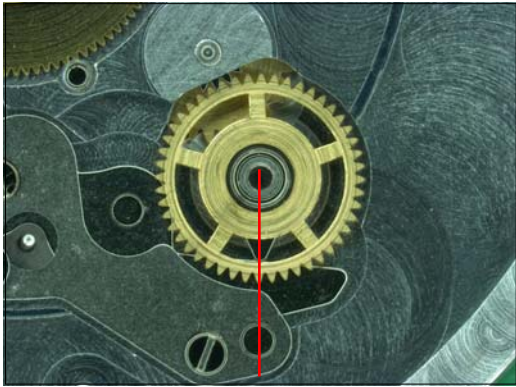

Fig. 1.0.1



### 1.0 Assembling of date indication

1. Stem in position 3: Turn anti-clockwise the driving wheel for date unlocking yoke (reference 33029) until the finger of this wheel is aligned with the pin, see Fig 1.0.
2. Assemble the date indicator, the date jumper and the date jumper spring
3. Position the date indicator driving wheel (ref 33020) so that the finger is as close as possible to one tooth of the date indicator, in direction clockwise. (Fig 1.0.1)
4. Assemble the mechanism cover, ref 10210.

Fig. 2.0a

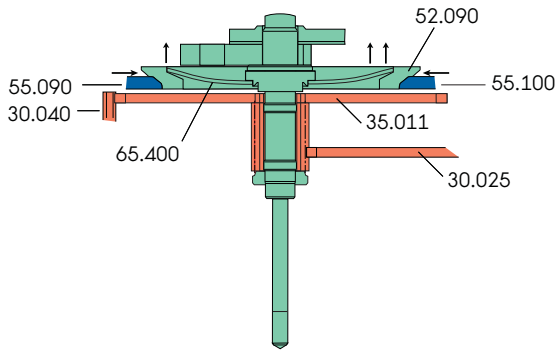
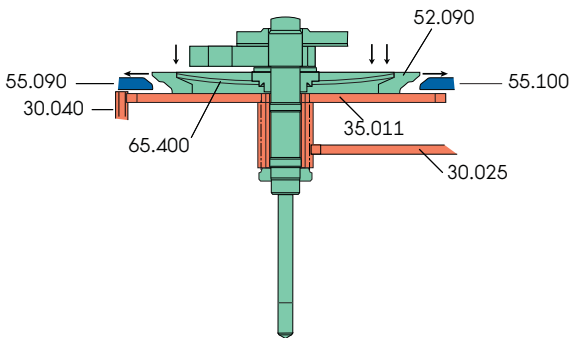

Fig. 2.0b



## 2.0 Chronograph wheel function

### Chronograph wheel 35.010\*\*

Chronograph wheel 35.010\*\* is equipped with a coupling system by which the chronograph can be coupled with and uncoupled from the movement's gear-train.

#### Do not clean

Chronograph wheel (35.010\*\*):

The chronograph wheel can only be lubricated during the manufacturing process. Cleaning damages the lubrication and could leave cleaning solution residue at the chronograph wheel, which interferes with operating and timing.

#### Chronograph stoppage position

In chronograph stoppage position, clutch disc 52.090 is raised following clamping by clutch rocker 55.090 and clutch lever 55.100, thus avoiding contact with chronograph pinion 35.011 which is constantly coupled with the movement's gear-train.

#### Chronograph operating position

In chronograph operating position, clutch disc 52.090 is released simultaneously by clutch rocker 55.090 and clutch lever 55.100. Pushed by chronograph wheel friction spring 65.400, it comes to rest on chronograph pinion 35.011 which will drive it in its travel.

Fig. 2.1

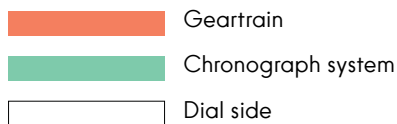

## 2.1 Description of chronograph system

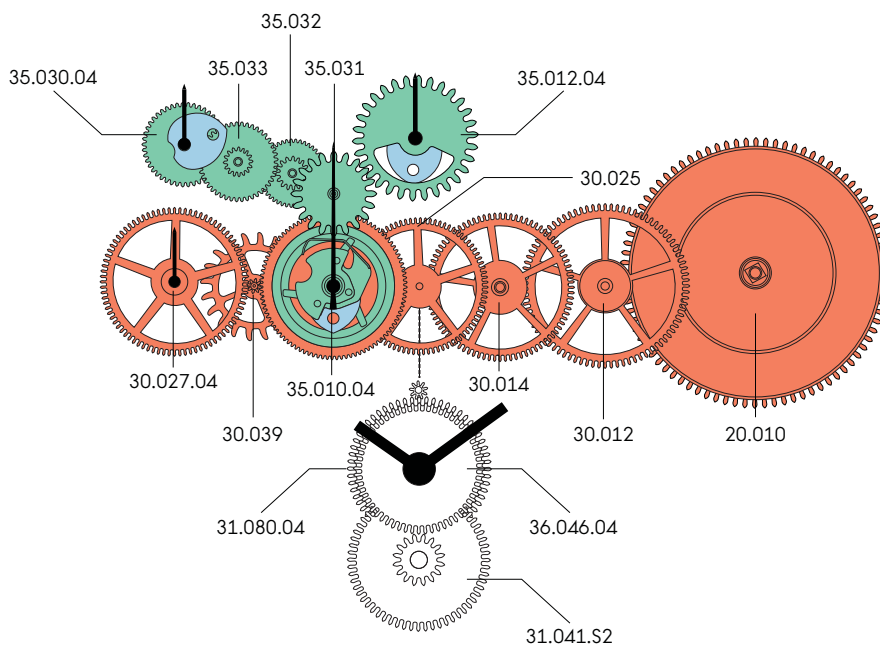
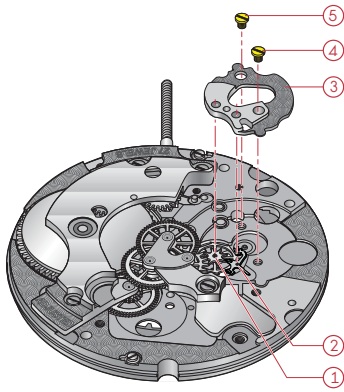

Fig. 3.1



### 3.0 Escapement and Balance bridge installation

#### 3.1 Escapement system installation

The pallet fork bridge holds the coaxial wheel in place as well as the pallet fork. The assembly order below must be respected for the escapement to function correctly:

1. Fit the coaxial wheel.
2. Fit the pallet fork.
3. Fit the pallet fork bridge and check that the respective pivots are firmly engaged in the housings.
4. **The assembly order for the two pallet fork bridge screws must be respected.** To position the pallet fork bridge, screw (4) must be screwed in first.
5. The second screw (5) ensures that the bridge is held firmly in place.

Fig. 3.2

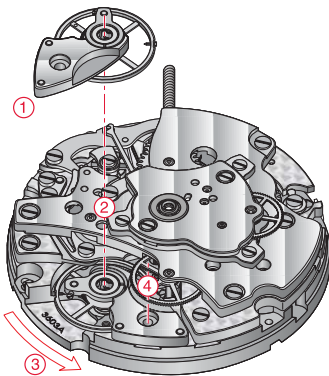

#### 3.2 Balance bridge installation

As the table roller is under the pallet fork, the balance must be assembled carefully.

1. Position the balance bridge with its balance, the position of the bridge must be in a 90° angle to its normal place.
2. Check the correct balance position. The pivots must be accurately fit into the shock-absorbers.
3. Turn the bridge carefully to its normal position.
4. Tighten the bridge screw.

Fig. 3.3

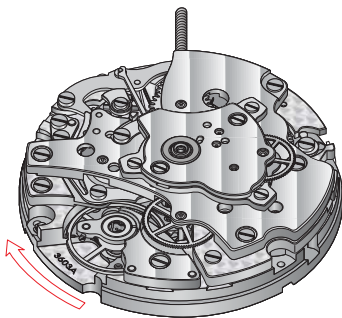

#### 3.3 Disassembling of the balance bridge

The balance bridge must be disassembled by removing the parts in the opposite order of procedure 3.2.

To avoid any risk of damaging the balance, the bridge has to be turned 90° degrees in the direction of the arrow. In this position the bridge may be disassembled without any risk.

## 4.0 Chronograph adjustment

Fig. 4.1

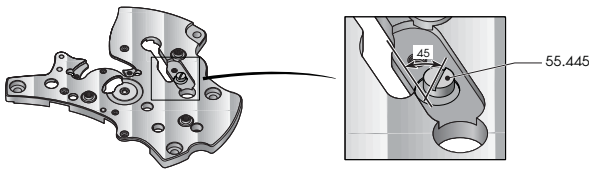

### 4.1 Check on the eccentric screw for the counter jumper(55.445)

The eccentric screw (55.445) of the counter jumper (55.143) must be positioned as in the drawing. The slot of the eccentric screw (55.445) must form an angle of 45° in relation to the recess in the bridge. An additional correction is subsequently possible when the chronograph is being set. Do not forget to place the hour hammer (55.248) under the bridge and lubricate it.

Fig. 4.2

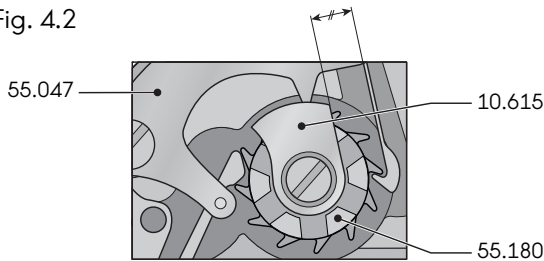

### 4.2 Hammer-lever banking bridge (10.615)

The hammer-lever banking bridge (10.615) prevents the hammer operating lever (55.047) from moving into an unsuitable position. It should be positioned above the hammer operating lever (55.047) and its straight flank should be parallel to the hammer operating lever spring (65.047).

Fig. 4.3

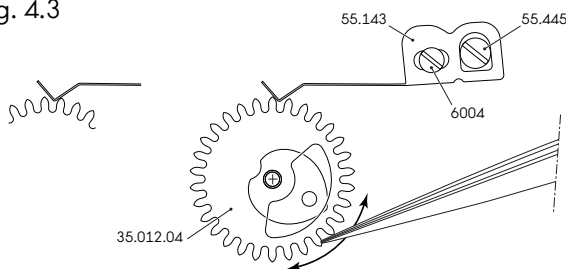

### 4.3 Check on position of minute counter (35.012\*)

Place the chronograph in reset position. Using a plastic or brass point, move the minute counter (35.012\*) slightly to the left and right. It is important that the minute counter should return correctly to its original position. With the eccentric screw (55.445), the position of the counter jumper (55.143) can be corrected.

Fig. 4.4 - Drawing 1

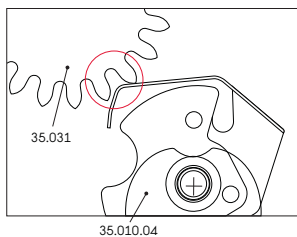
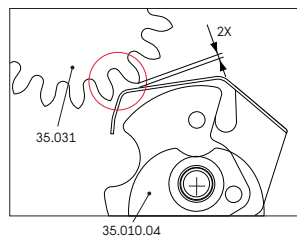

Fig. 4.4 - Drawing 2



### 4.4 Check on location of chronograph finger in reset position

Check the location of the chronograph finger in reset position. To ensure good synchronisation between the second counter and the minute counter, the chronograph finger should be between the position of «slight contact against the tooth» (see drawing 1) and a maximum distance of twice the thickness of the finger blade (see drawing 2).

### 4.5 Chronograph finger operating safety

Put the chronograph in START position. Check that the minute counter jump is operating correctly by checking the penetration of the chronograph finger.

Fig. 4.5

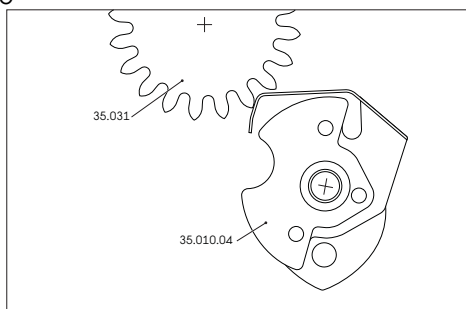

### 4.6 Checking the minute jump

In the START position, drive the chronograph hand with a brass or plastic point until the minute jumps. The difference in relation to the position of the chronograph's seconds hand in the zero setting position has a tolerance of 2/5 second. Check the function of the counter jumper (55.143) on the hand.

Fig. 1

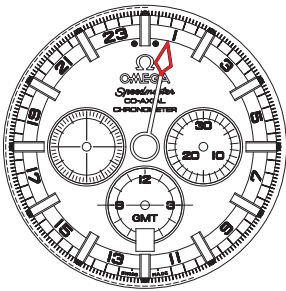

Fig. 2

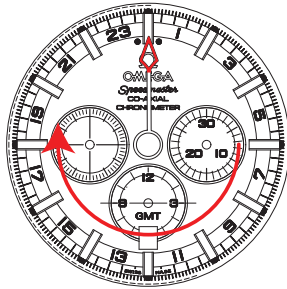

Fig. 3

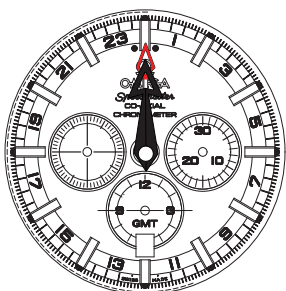

Fig. 4

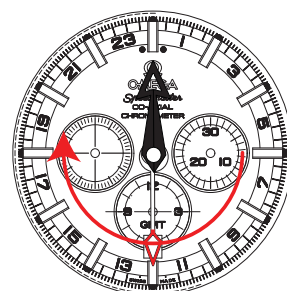

Fig. 5

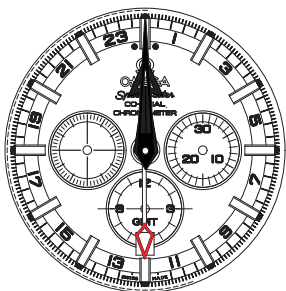

Fig. 6



Fig. 7



## 5.0 Hand setting for calibre 3603

### General:

To fit the hands, the movement must be placed in a well adjusted movement holder.

Please consult **Working Instruction No 5 & 28** for tolerances and specification.

### Procedure:

1. **Set all small hands**  
(Hour counter hand, minute counter hand and small second hand)
2. **Set GMT-hand to +2'.** See figure 1.  
The moment the date jumps, set the hand to +2 minutes, due to the tolerance of date jump mentioned in Working Instruction No 28.
3. **Turn clockwise the GMT-hand and set it to 24 o'clock.**  
See figure 2.
4. **Set hour hand.** See figure 3.
5. **Turn clockwise hour hand to 12 o'clock.** See figure 4.  
(The GMT hand should be opposite)
6. **Set minute hand.** See figure 5.
7. **Set chronograph hand**
8. **Check end shake and distance between all hands again.**

## 5.1 Checks, to carry out after hand-setting:

### Check No 1:

Pull the crown in position 2, turn hour hand counter-clockwise until the date jumps. See figure 6.

**Check: The date must jump between 01 am and 12 pm.**

### Check No 2:

Pull the crown in position 2, turn hour hand clockwise until the date jumps. See figure 7.

**Check: The date must jump between 12 pm and 01 am.**

## 6.0 Principle of GMT function

The principle behind the GMT function is that the GMT hand (or 24-hour hand) is always running.

The hand is set on the 24-hour wheel ref. 31047.

This means it makes 1 turn every 24 hours.

The minute hand is set on the cannon pinion with driving wheel ref. 31080, and it makes 24 turns in 24 hours. The hour hand is set on the hour wheel with time-zones ref. 36035, and it makes 2 turns in 24 hours.

When the time zone needs to be adjusted, the shift has to be done on the hour hand using the hour wheel with time-zones. The GMT hand always maintains its initial position.

Fig. 6.1.1

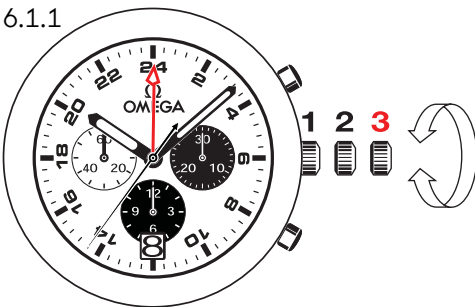

Fig. 6.1.2

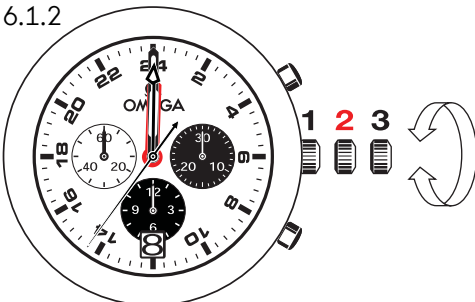

Fig. 6.1.3

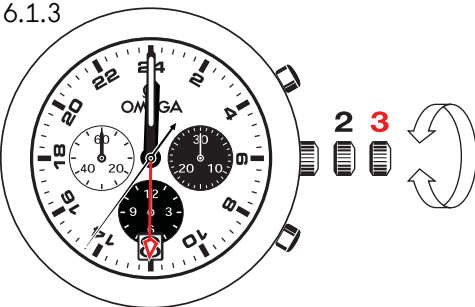
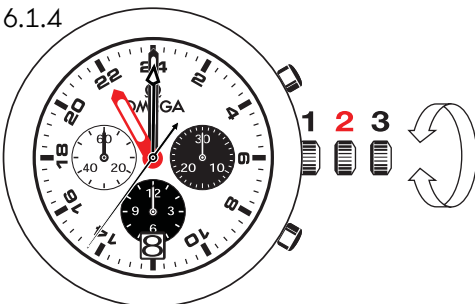

Fig. 6.1.4



### 6.1 Adjusting GMT

To synchronize the hour hand and the GMT hand, both hands must be brought together. To do this, follow these directions: position the GMT hand at 24 o'clock (midnight) by hand setting (see fig. 6.1.1), then correct the hour hand in order to superimpose it on the GMT hand (see fig. 6.1.2).

When the hour hand is at noon (12 o'clock), the GMT hand will be positioned opposite (at 6 o'clock) (see fig. 6.1.3), indicating 12 o'clock on the GMT scale.

Now if we change time zone, for example by travelling from Paris to London with a time difference of -1 hour, the hour hand needs only to be moved back one hour (see fig. 6.1.4). When it is noon (12 o'clock) in London, the GMT hand will indicate 13 o'clock (for Paris) on the GMT scale (see fig. 6.1.5).

Fig. 6.1.5

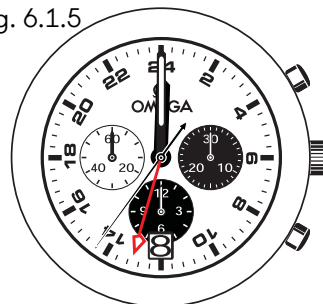
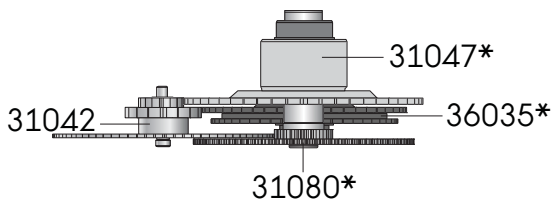

Fig. 6.2.1



**6.2 Mechanism function during normal use or time setting**  
 The cannon pinion with driving wheel ref. 31080 drives the minute wheel ref. 31042. This wheel is unique in that it has 2 pinions of different diameters.

The lower pinion (large diameter) drives the hour wheel with time-zones ref. 36035 using its upper plate (large diameter). The upper pinion of the minute wheel (small diameter) drives the hour wheel 24 H ref. 31047.

The hour wheel 24H and the hour wheel with time-zones thus turn along the same axis, in the same direction, but with a speed ratio of 2.

Fig. 6.3.1

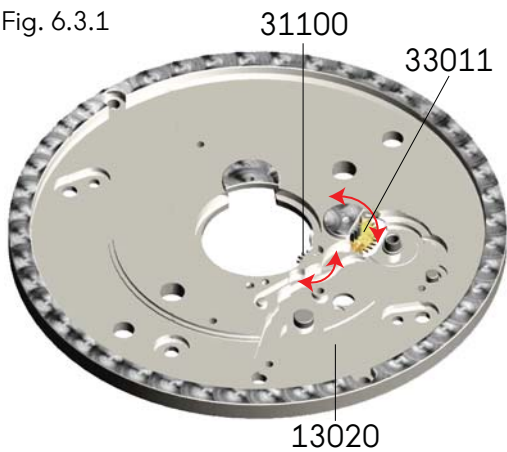

### 6.3 Mechanism function during a quick time zone correction

A quick time zone correction should be done when the winding stem is in position 2. This correction is possible either forward or backward.

Transmission occurs using the corrector wheel time-zone ref. 36031, which drives the intermediate date wheel ref. 33011 thus driving the setting wheel for time-zones ref. 31100. These two moving parts are assembled beneath the calendar plate ref. 13020.

Fig. 6.3.2

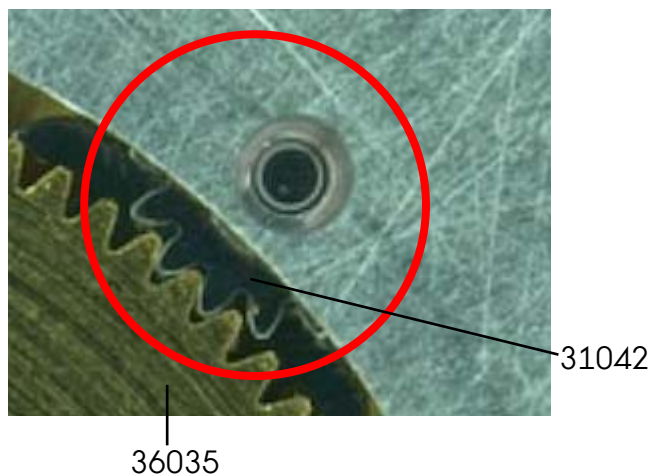

The setting wheel for time-zones ref. 31100 drives the lower plate of the hour wheel with time-zones ref. 36035.

In this phase, the ratchet system slowly disengages, releasing the hour hand in a 1-hour jump. For that this function is working, the upper plate of the hour wheel with time-zones ref. 36035 is blocked by the upper pinion of the minute wheel ref 31042.

Fig. 6.4.1

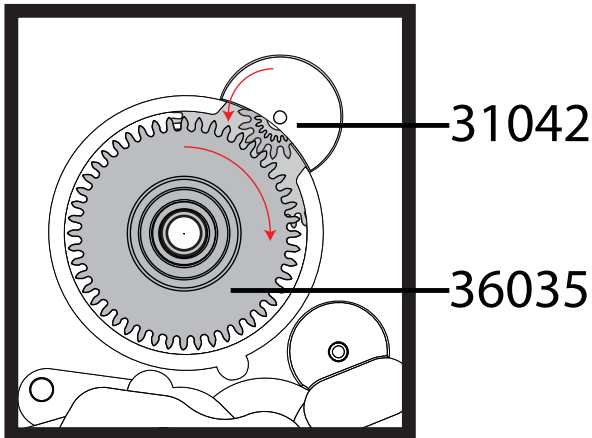

**6.4 Date mechanism function**

During normal use, the minute wheel ref. 31042 drives the hour wheel with time-zones ref. 36035 by its upper plate (Fig. 6.4.1).

The torque is transferred to the lower plate of this wheel through the ratchet system (Fig. 6.4.2).

The lower plate of the hour wheel with time-zones ref. 36035 pulls the setting wheel for time-zones ref. 31100 which drives the intermediate date wheel ref. 33011 (Fig. 6.4.3). The pinion of the intermediate date wheel pulls the driving wheel for date unlocking yoke ref. 33029 which then drives the date indicator driving wheel ref. 33020 (Fig. 6.4.4).

The position of the finger beneath the wheel (ref. 33029) compared to the date indicator indicates the correct placement during assembling (Fig. 6.4.5).

The driving wheel for date unlocking yoke ref. 33029 turns on a stud of the date unlocking yoke ref. 53040 (Fig. 6.4.6). The finger of the driving wheel for date unlocking yoke ref. 33029 touches (Fig. 6.4.7) the unlocking yoke each midnight (once/24 hours) and positions the date indicator driving wheel ref. 33020 between the teeth of the date indicator, making the indicator jump one day.

Fig. 6.4.2

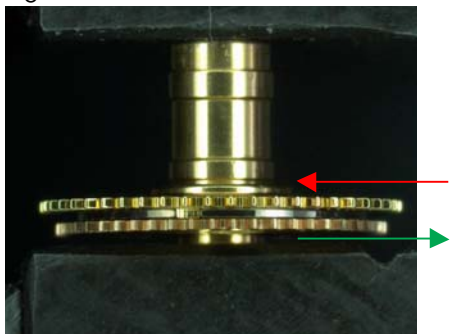
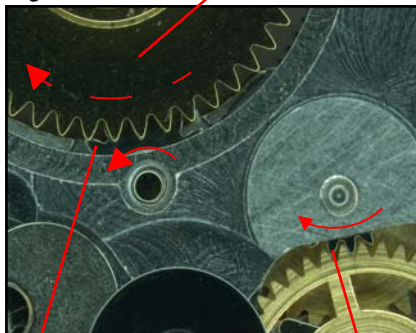
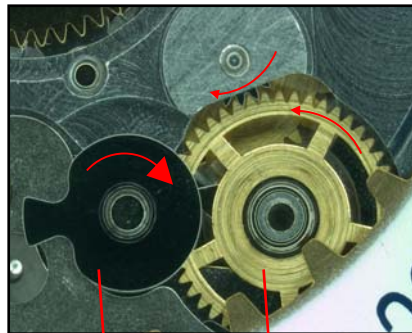

Fig. 6.4.3



31100 33011

Fig. 6.4.4



33020 33029

Fig. 6.4.5



33029

Fig. 6.4.6

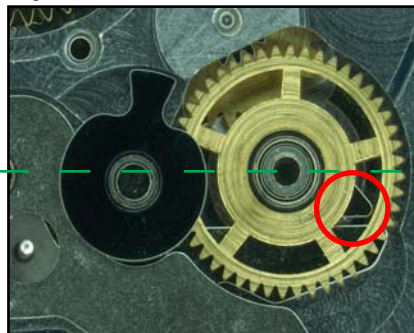
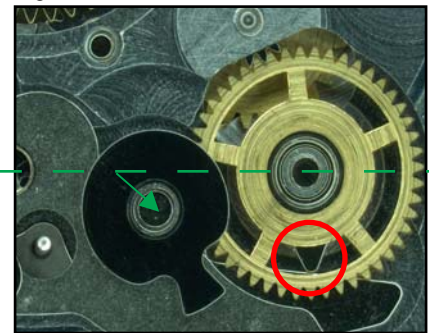

Fig. 6.4.7













### 7.0 Runners for hand setting and hand setting force

Description	Movement holder for hand setting	No. of runners for hand setting	Minimum force (N)	Maximum force (N)	Support (jewel)
GMT hand	507 0001	8	10	50	No
Hour hand		6	10	50	No
Minute hand		2	10	50	No
Chrono seconds hand in the centre		1	40	60	Yes
Second hand (small)		1	10	40	Yes
Hour counter hand		1	25	50	Yes
Minute counter hand		1	25	50	Yes

### 8.0 Epilame coating

#### 8.1 Components that should not be epilam-treated after cleaning

Description	Reference	
Balance fitted on balance bridge	40055 + 10058°	
In settings, upper *	32127	
In settings, lower *	32167	
Pallet bridge, Co-Axial	10057	
Barrel ***	20010	
Slipping mainspring	20100	
Pallet fork	40010	
Hour-counting wheel	35030**	
Chronograph wheel **	35010**	

\* Do not treat the shock-absorber settings with epilam; the cap jewels should however be treated.

\*\* Do not clean the chronograph wheel.

\*\*\* Do not treat the complete barrel with epilam, only the drum, cover and arbour separately.

For additional information see Working Instructions No 27.

## 9.0 Instantaneous rate

### 9.1 Check of the instantaneous rate

Demagnetise the movement before the checks according to Working Instruction 34.

The timing of the movement has to be according to the Omega timing specification list.

**Please consult Working Instructions 5 and 28 for instructions and tolerances.**

Instrument type	Co-axial, 4 Hz calibres	Comments
<b>Former Witschi instruments</b> - Watch Expert (red case) - Wicomètre Professionnel - Chronoscope M1 (former version)	Lift angle, set to 30°	
	All measurements are correct	
<b>New Witschi instruments</b> - Watch Expert II + III (white case) - Chronoscope M1 (updated version) - Chronoscope S1	Lift angle, set to 38°	<b>Test mode: parameters must be set to «Spe1»!</b>
	All measurements are correct	

Fig. 9.2

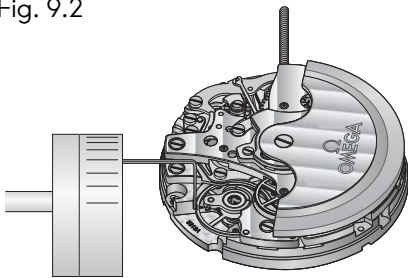

Fig. 9.3

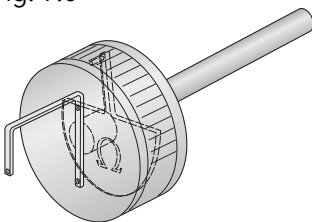
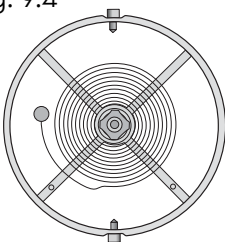

Fig. 9.4



### 9.2 Rate adjustment

A special timing key tool (see Figure 9.3) has been developed to adjust the rate even when the movement is cased in. The rate can be corrected according to the table below by turning the two balance screws a complete turn. A scale is found on the outside of the tool. A division corresponds to a rate correction of 1 second. (according to the table below). One screw is located between two arms on the balance which are specially marked by points (see Figure 9.4) for easy identification of each screw during the correction process.

#### Balance

The annular balance has two adjusting micro-screws. A slow rate deviation is corrected by tightening the micro-screws (towards the centre of the balance), which reduces its moment of inertia and makes it run faster. A fast rate deviation is corrected by loosening the micro-screws (away from the centre of the balance). This increases its moment of inertia and makes it run slower.

#### Important:

The rate is always corrected using **both adjustment screws** to prevent an unbalance of the balance.

Versions A & B identical
One correction revolution = 57 seconds
One graduation = 1 second